



95 years of experience in sealing solutions

A reference in the industrial sealing sector, **GROUPE LATTY®** owes its leadership to its willingness to invest in Research & Development of specific products for your equipment.

GROUPE LATTY® design and manufacture products that comply with the most demanding industrial requirements.

GROUPE LATTY® is present in the following sectors:

- Petrochemicals
- Energy
- Chemicals
- Pharmaceuticals
- Cryogenics
- Food processing
- Nuclear energy

and offers:

- Complete solutions suitable for each type of pumps
- Complete ranges of industry standard or custom specific products
- Research and testing laboratory
- Achieving type approval of your equipment
- Training adapted to your needs
- A French product, guarantee of quality

FORMATIONS



A well-trained employee is more skilful and efficient!

Training modules are more specifically dedicated to the selection of sealing solutions for industrial equipments. Oriented towards the implementation and good mounting practices, guarantee of security for your teams and the reliability of your equipment.

Each year many multilingual training, either in our plant or at customer centers are organized on:

- Valves
- Rotary units
- Bolted assemblies

We are an approved training organization.

LABORATORY R&D



Des solutions testées sur votre matériel

GROUPE LATTY® invests an average of 5% of its annual turnover in Research and Development for new products and processes. The company has a test laboratory at its factory enabling it to test its products in optimum use conditions, including its clients' own equipment.

Research is essentially based on the resolution of clients' problems, which may be:

- to reduce friction loads,
- to use simple, efficient equipment,
- to reduce maintenance time,
- to have innovative products.

For several years, **GROUPE LATTY®** has invested in its own test laboratories, installed on over 500m², with more than 15 test cells, equipped with precision measurement equipment:

- pressure: from vacuum to 650 bars
- temperature: from -200°C to 650°C with the possibility to carry out thermal shocks
- speed: from 0 to 6000 rpm
- several helium mass spectrometers for leak measurement.

GROUPE LATTY® is a member of the Fluid Sealing Association (FSA) and the European Sealing Association (ESA)

DIRECTIVES, NORMES ET HOMOLOGATIONS

Nos différentes gammes de garnitures mécaniques répondent aux homologations, directives et normes suivantes :



ROTARY UNIONS

LATTYseal RT



GROUPE LATTY® has taken advantage of their know-how in the sealing area to develop a range for rotary union applications. Rotary unions are used to create a tight connection between fixed piping and mobile piping.

There are many applications within the sectors of bottling, filling, machine tools, automobile, heating and cooling systems. Based on the specifications drafted together with the customer, innovative technical assemblies are proposed, with special economic focus on design and maintenance.

ADVANTAGES

- Conveys one or several fluids simultaneously from fixed piping and mobile piping.
- Withstands a wide range of working pressures/temperatures/speeds
- Suitable for use at the end of a shaft or for through shafts.
- Available in different sizes
- Suitable for any type of industries
- Liquid media (slurries or clear fluids) and/or gas (neutral or aggressive)
- Tightness tests prior to delivery
- Tailor-made product

CERTIFICATIONS

- EHEDG (hygiene)
- FDA (food)
- EC 1935/2004 (food)
- ACS (drinking water)
- ATEX (Explosive)
- WRAS (drinking water)

Other certifications on request.

DIMENSIONS

- Shaft diameter from 2 mm to 200 mm
- Height from 3 cm to 180 cm

Other diameters and dimensions on request

PARAMETERS (not associated)

- Pressure: 0 to 100 bars (10 MPa)
- Temperature: from -196°C to 250°C (from -320.8°F to 482°F)
- Speed: 6,000 rpm

Other parameters on request

EQUIPMENTS

- Filler
- Centrifuge
- Mixer
- Filter-drier
- Crusher
- Blower
- Cooker
- Washing equipment
- CIP/SIP-cleaning
- Others

TYPES OF INDUSTRIES

- Food processing
- Cosmetics
- Pharmaceuticals
- Paper
- Chemicals
- Petrochemicals
- Machine-tools
- Automobile
- Steel
- Medical
- Mining and quarrying
- Others



THE DIFFERENT TECHNOLOGIES

Depending on the fluids to be sealed, there are different types of rotary union technologies: friction seal or with mechanical seal.

FRICITION SEAL

Friction seal technologies are used for gas applications (nitrogen dioxide, air, steam, helium, etc.) or clear liquids (clean liquids, oil, detergent, nitrogen, etc.) and/or associated with slow speed.



INDUSTRY: CHEMICALS
Friction seal - 1 way - Ø110

- Fluid: Water
- Pressure: 70 bars
- Temperature: 90°C
- Speed: 7 rpm



INDUSTRY: FOOD PROCESSING
Friction seal - 2 ways - Ø180

- Fluids: Fruit juice, tea, CIP
- Pressure: < 5 bars
- Temperature: < 115°C
- Speed: 12 rpm



INDUSTRY: STEEL
Friction seal - 2 way - Ø50

- Fluids: Steam and water
- Pressure: 3 bars
- Temperature: 110°C
- Speed: 25 rpm



INDUSTRY: PAPER
Friction seal - 2 ways - Ø100

- Fluids: Steam
- Pressure: 12 bars
- Temperature: 125°C
- Speed: 175 rpm

MECHANICAL SEAL

Mechanical seal technologies are used for slurries (chocolate, cream, ice, fuel oil, etc.) and/or associated with high speed.



INDUSTRY: MACHINE-TOOLS
Mechanical seal - 2 ways - Ø58

- Fluid: Glycol water
- Pressure: 4 bars
- Temperature: 40°C
- Speed: 3,000 rpm



INDUSTRY: FOOD PROCESSING
Mechanical seal - 2 ways - Ø80

- Fluid: Oil
- Pressure: 20 bars
- Temperature: 160°C
- Speed: 3,500 rpm



INDUSTRY: FOOD PROCESSING
Mechanical seal - 2 ways - Ø160

- Fluid: Water, juice, CIP/SIP
- Pressure: 5 bars
- Temperature: 145°C
- Speed: 50 rpm



INDUSTRY: COSMETICS
Mechanical seal - 1 way - Ø120

- Fluid: Cream
- Pressure: 10 bars
- Temperature: 135°C
- Speed: 40 rpm

THE DIFFERENT OPTIONS OF ROTARY UNIONS



GRUPE LATTY offers you a wide range of rotary unions adapted to your different needs with the guarantee of a suitable assembly in your equipment.

1 Assembly with ball bearing or roller bearing (to be lubricated or greased for life)

Choice depending on the type of assembly and loads applied. Ensures good concentricity and coaxiality of assembly, which offers the guarantee of long life and performance. Materials available: stainless steel, ceramics, thermoplastic, etc.

2 Friction seal with bush

Solution recommended for clear fluids and with speeds below 2 m/sec. The addition of a bush makes maintenance operations easier. No or very few coated areas
Possible approved: FDA, EC 1935/2004, ATEX, EHEDG.

3 Bellows mechanical seal

Solution recommended for high-temperature applications. Significant compensation for axial displacement in case of expansion.

4 Connections

Screwed-on flanges, welded flanges, etc.

5 Washing ball

Provides good cleanability

6 Assembly at the shaft end or on through shaft

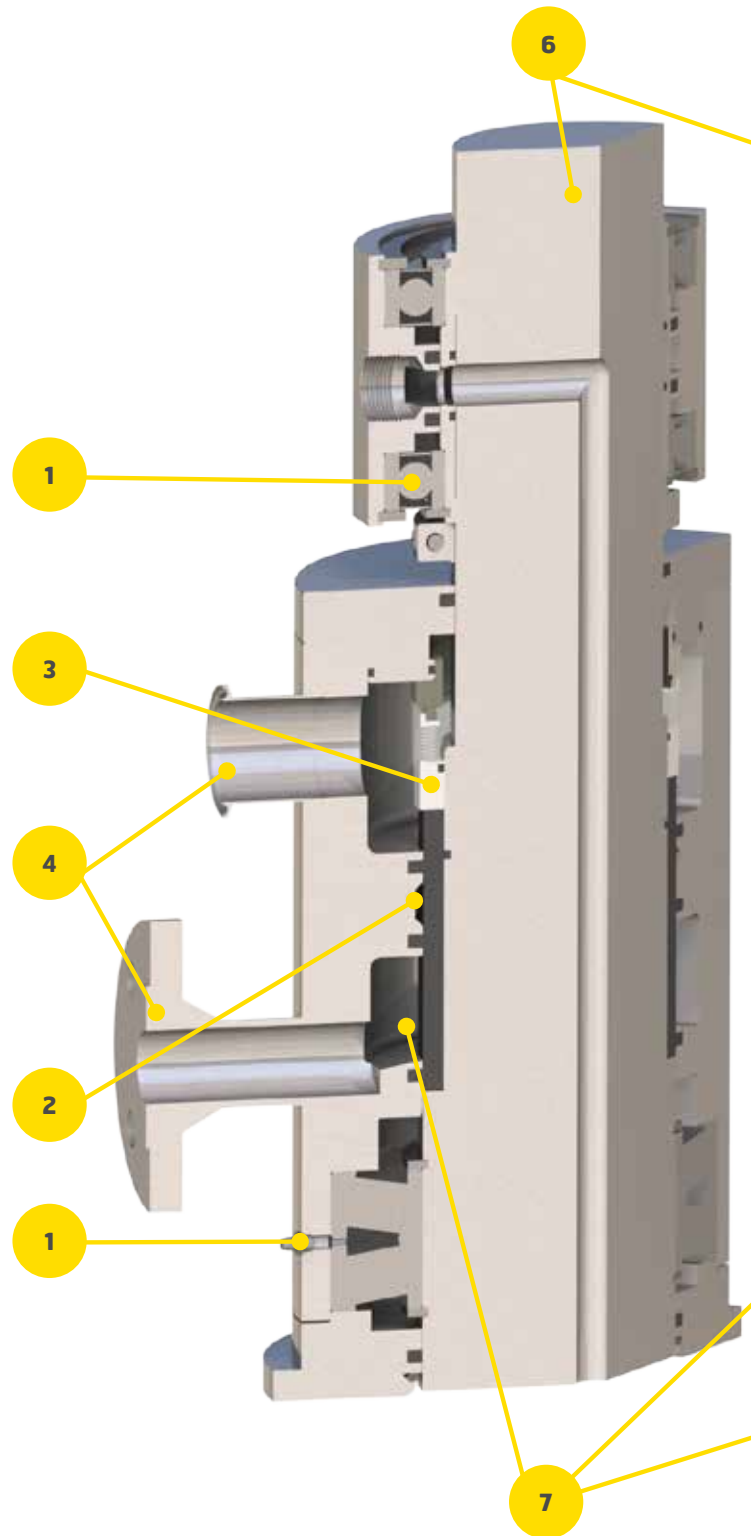

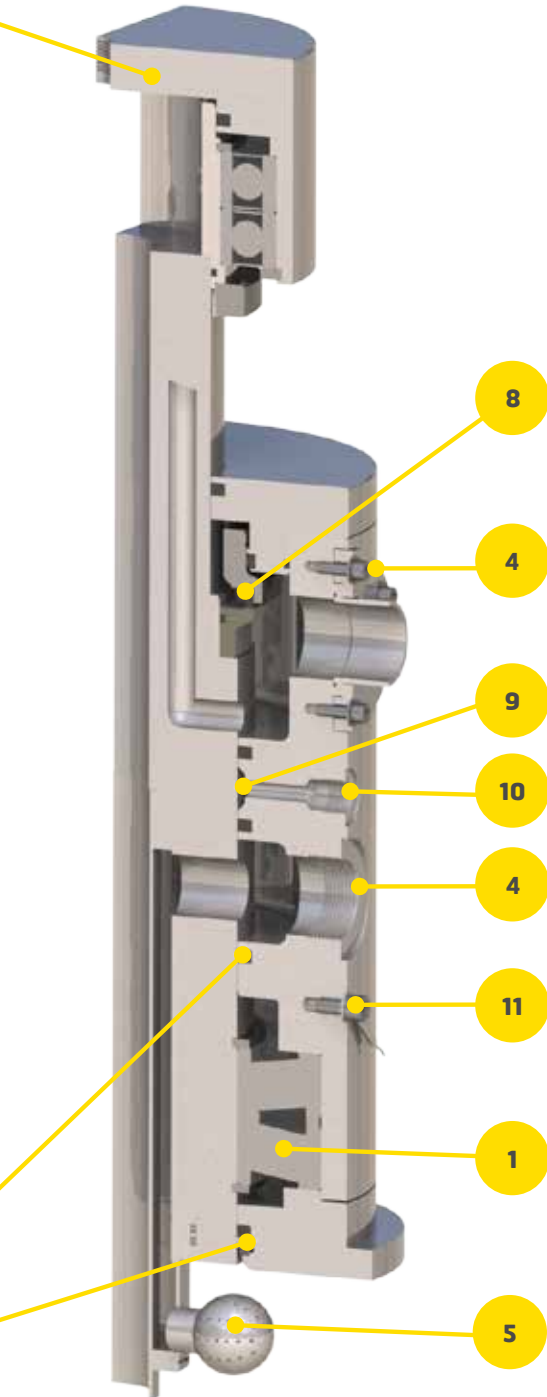
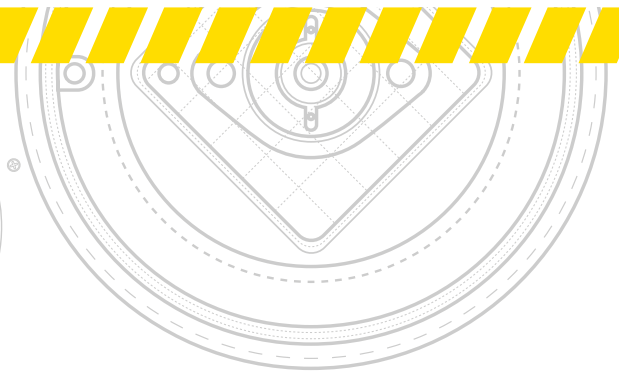

7 Limited retention areas

To comply with the different standards and nd guidelines; in particular in food environments

8 Mechanical seal

Solution recommended for applications with demanding operating conditions: clear and unclear fluids, high speeds and/or temperatures.

9 Friction seal with coating

Solution recommended for clear fluids and with speeds below 2 m/sec.
Recommended for large diameters.

10 Steam barrier or leak detector

A barrier fluid (or steam) is injected through openings to create an aseptisation effect. The steam barrier may be added as hygienic protection between two circuits or to perform sterilization procedures.

11 Measurement sensor

For the remote control and monitoring of the temperature, pressure, etc. of the rotary union. Required for sensitive applications such as ATEX Environments.

THE GROUPE LATTY SERVICE



GROUPE LATTY has built up its reputation by adhering to very strict quality rules that guarantee the reproducibility and security of its products. Our products are essential in ensuring the leak-tightness of complex industrial processes.

The quality of their raw material and their lifespan allows our customers:

- to extend the lifetime of their production tool,
- to reduce maintenance costs,
- to ensure security and protect the environment.



DESIGN

Our technicians and engineers work upstream of projects in collaboration with our customers in order to define the specifications. The specifications may be completed with some on-site visits in order to better understand and take into account the project-specific problems and consider all possible options.

In the design phase, our rotary unions are systematically modelled using CAD/CAM software in order to anticipate their behaviour when in operation.



PRODUCTION

Manufactured and assembled on our production site in Brou (France), each rotary union is unique due to its design and production even when manufactured in series in compliance with specific procedures and with our ISO 9001 qualification.

Endurance tests are carried out on each rotary union in order to validate the design and materials. As a result, we can steadily improve our products and commit ourselves to guaranteeing compliance with the requirements of equipment manufacturers. These tests ensure our customers the supply of rotary unions will be up to their expectations.



MAINTENANCE

Our technicians can advise you or train your personnel on the preventive maintenance procedures for your rotary unions. Maintenance sets are available for wear parts.



REPAIR

After assessment and based on a cost estimate, we carry out the repair, the rehabilitation works and the improvement of any type of rotary union. Repaired rotary unions may be subjected to control tests on our test benches.





LATTY INTERNATIONAL S.A.
57 bis, rue de Versailles
91400 ORSAY - FRANCE
Tel. +33 (0)1 69 86 11 12
sales-marketing@latty.com

LATTY ARGENTINA S.A. *
Nuestra Sra. de la Merced 5334
(1678) CASEROS PCIA. DE BS. AS.
ARGENTINA
Tel. +54 (11) 4734 8481
ventas@latty.com.ar

LATTY BELGIUM S.A./N.V.
Chaussée de Namur 92 bte 07
1300 WAVRE - BELGIUM
Tel. +32 (0)10 24 62 08
info@latty.be

LATTY DICHTUNGSTECHNIK A.G. *
Henzmannstrasse 39
4800 ZOFINGEN - SWITZERLAND
Tel. +41 (0)62 752 20 84
latty@Bluewin.ch

LATTY IBERICA S.L. ESTANQUEIDAD
Pedro IV, 29-35, 4º 6º
08018 BARCELONA - SPAIN
Tel. +34 (93) 356 99 90
latty@latty.es

LATTY INTERNATIONAL Ltd *
Westfield Road - RETFORD
Notts, DN22 7BT - ENGLAND
Tel. +44 (0)1 777 708836
sales@latty.co.uk

LATTY MAROC TECHNISEALS S.A.R.L. *
51, rue Hadj Ahmed Balfrej
B.P. 3167
20290 CASABLANCA - MOROCCO
Tel. +212 (0)5 22 24 80 90
lattymaroc@menara.ma

LATTY 2RS GmbH *
Im Auel 22
D-53783 - EITORF
GERMANY
Tel. +49 (0)2243 / 84658-0
latty2rs@latty.de

LATTY SOUTH AFRICA Ltd *
108 Billingham Rd, Founders View South
Modderfontein, Edenvale, 1610
SOUTH AFRICA
Tel. +27 (0)11 452 9755
support@latty.co.za

LATTY CENTRAL & WEST AFRICA
BP 32852
ABIDJAN 10 - IVORY COST
Tél. : +225 220 100 06
latty.cwa@latty.com

LATTY CHILI SpA
Avda. Echeñique 6664-A
La Reina
7850398 SANTIAGO - CHILE
Tél. : +56 2 2933 4957
araneda@lattychile.com

LATTY Seal Service
Service center for mechanical seals repair
and repackaging

LATTY MECASEAL
2, impasse du Crachet
Zone Artisanale
59193 ERQUINGHEM - LYS
FRANCE
Tel. +33 (0)3 20 77 12 89
lattyseal.service@latty.com

LATTY MECANETANCHE
174, rue des Saules
Z.I. Le Chapelier
38110 SAINT-JEAN DE SOUDAIN
FRANCE
Tel. +33 (0)4 74 97 01 09
lattyseal.service@latty.com



Rotary Units

*Subsidiaries with workshop for mechanical seals repair and repackaging.

LATTY BROU (10/2016) - Réf 900020176



PLANT
1, rue Xavier Latty - F-28160 BROU, FRANCE
Tel. +33 (0)2 37 44 77 77. Fax. +33 (0)2 37 44 77 99
customerservice@latty.com

www.latty.com

