

# EM Series Electro Module

## Individual Clutch or Brake Module Combine to Comprise a Clutch, Brake or Clutch/Brake Combination

Electro Modules are individual clutch or brake units which are assembled together to comprise a clutch, brake, or clutch/brake combination. Electro Modules can be bolted directly to a NEMA C-face motor or reducer or they can be base mounted for stand alone operation. Electro Modules offer the ultimate in clutch/brake convenience. They are easy and quick to install and require no lubrication or maintenance for life.

### Bolt-it-down and wire-it-up ... it's ready to go!

- Modular design flexibility
- 1/4 to 7-1/2 HP at 1800 RPM
- Outstanding controllability
- Fast cycling
- Smooth starts and stops
- Accurate
- Bidirectional
- Consistent performance
- Complete control capability

### Selection Flexibility Clutch/Brake Combination

A wide range of module combinations for use with motors, reducers and other standard power transmission components is available. The flexibility of Electro Module enables you to pick the exact combination of function and design.

### Power-On Applications

Electro Modules for power-on applications are purchased as individual clutches and brakes to be assembled for C-face, flange, or base mounting applications.

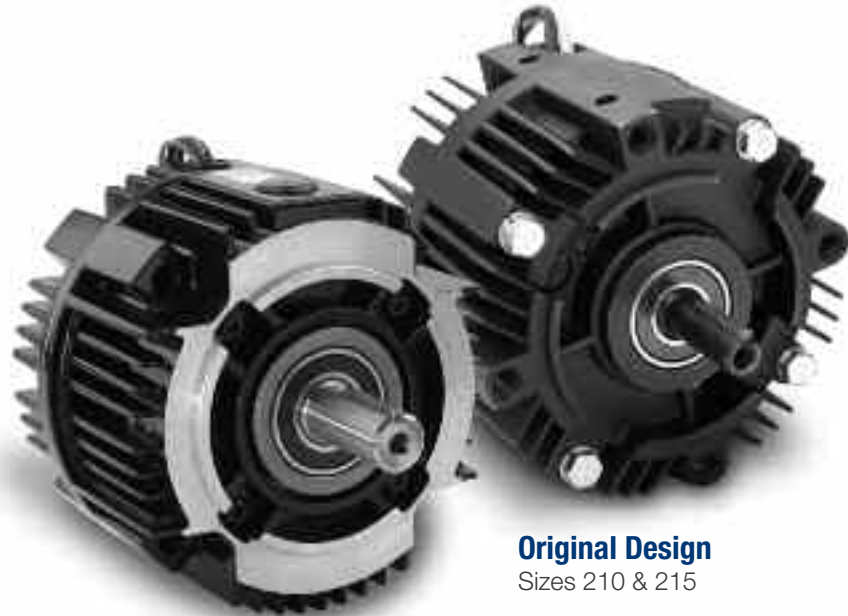

### GEN 2 Design

Sizes 50, 100 & 180

### Original Design

Sizes 210 & 215

### Power-Off (Electrically Released) Applications

Electrically released operation is the primary feature of power-off Electro Module brakes. They can be used as brakes, motor brakes and in combination with clutches. See page 106 for complete information.

### Selection

The correct size can be determined from easy-to-use selection charts based on NEMA frame sizes or horsepower and shaft speed. Examples show the right way to order the Electro Module required.

### Controls

Warner Electric controls assure that you get the maximum performance from your Electro Module. See page 201.

## Modular Components

### Clutch Modules



#### 10 Motor Clutch

Fan cooled for long life and consistent performance. See page 30.



#### 30 Input Clutch

Fan cooled. Sealed coil. Twin bearing mounted shaft maintains tight concentricities. See page 33.



#### 40 Output Clutch

Autogap™ automatically adjust armature for wear. Does not have a coil – use in combination with a 10 Motor Clutch or 30 Input Clutch module. See page 34.

### Brake Modules



#### 20 Brake

Bolts directly to C-face components. See page 31.



#### 20MB Motor Brake

Does not have a shaft. Has end cap. See page 32.

### Clutch Combinations



#### 10/40

#### Motor Clutch/Output Clutch

Use for clutch only applications. Has hollow bore input for mounting directly to C-face motors. Shaft and C-face on output side of unit accommodates reducer, parallel drive or coupling. Basic components are field, rotor and armature. See page 36.



#### 30/40

#### Input Clutch/Output Clutch

Use for clutch only applications. Features dual C-faces and shafts. Unit input from parallel drive or coupling. Output to reducer. Basic components are field, rotor and armature. See page 38.



#### 30/40-B

#### Input Clutch/Output Clutch-Base Mounted

Base mounting allows the clutch units to be utilized as a separate drive unit. Attach with pulleys, sprockets, etc. See page 38.

### Clutch/Brake Combinations



#### 10/20

#### Motor Clutch/Brake

Use for clutch/brake applications. Hollow bore input. Shaft on output side. Basic components are field, rotor, 2 armatures and power-on magnet. See page 35.



#### 20/30

#### Brake/Input Clutch

Use for clutch/brake applications. Features dual C-faces and shafts. Input from parallel drive or coupling. Output to reducer. Basic components are field, rotor, 2 armatures and power-on magnet. See page 37.



#### 20/30-B

#### Brake/Input Clutch-Base Mounted

Stand alone units attach with pulleys, sprockets, etc. See page 37.

# EM Series Electro Module

## Selection

Electro Module clutch or brake units may be mounted directly to NEMA C-face motors and reducers, or can be base mounted.

### 1. Select Configuration

#### a. NEMA C-face Mounting

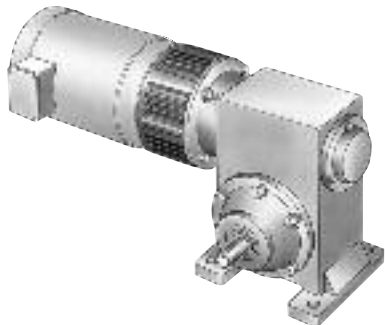

Based on the NEMA C-face frame size of the prime mover, select the correct clutch or brake module size from the Frame Size Selection chart. Size 100 houses the components of the size 180 in a size 50 frame, while size 215 incorporates size 210 components.

#### b. Base Mounting

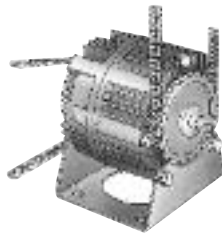

Electro Module assemblies may be mounted as separate drive units driven from the prime mover by V-belts, chain and sprockets, couplings, timing belts and other standard power transmission components.

Select the correct size module from the Horsepower vs. Shaft Speed chart by determining the motor horsepower and RPM at the module location. The correct size Electro Module is shown at the intersection of the HP and operating speed.

For additional sizing information, refer to the technical sizing procedure (step 2).

### 2. Determine Technical Requirements

Technical considerations for sizing and selection are torque and heat dissipation. Each merits careful consideration, especially heat dissipation as over time, use in excessive temperature environments will have an adverse effect on bearing life and coil wire insulation integrity.

Compare the calculated torque requirement with the average dynamic torque ratings. Select a unit with adequate torque. If the unit selected on torque is different than the unit selected based on heat, select the larger size unit.

### Frame Size Selection

NEMA Frame Size	Electro Module Size
56C/48Y	EM-50* EM-100**
182C/143TC 184C/145TC	EM-180
213C/182TC	EM-210
215C/184TC 213TC/215TC	EM-215

\* For 56C/48Y Frame motors 3/4 HP and smaller the UM-100 size may be used where extended life is desirable.  
\*\* UM-100 size is recommended for motors 1 HP and larger.

### Horsepower vs. Shaft Speed

HP	SHAFT SPEED AT CLUTCH (IN RPM)																		
	100	200	300	400	500	600	700	800	900	1000	1100	1200	1500	1800	2000	2400	3000	3600	
1/4																			
1/2														EM-50					
3/4																			
1																			
1-1/2														EM-100 or EM-180					
2																			
3																			
5																			
7-1/2																			

## a. Heat Dissipation Sizing

Friction surfaces slip during the initial period of engagement and, as a result, heat is generated. The clutch/brake selected must have a heat dissipation rating greater than the heat generated by the application. Therefore, in high inertia or high cycle rate applications, it is necessary to check the heat dissipation carefully. Inertia, speed and cycle rate are the required parameters.

Heat dissipation requirement is calculated as follows:

$$E = 1.7 \times WR2 \times (N/100)^2 \times F$$

where:

$$E = \text{Heat (lb. ft./min.)}$$

WR2 = Total reflected inertia at the clutch/brake shaft. Include the clutch/brake output inertia. (lb.ft.2)

N = Speed in revolutions per minute (RPM)

F = Cycle rate in cycles per minute (CPM)

Compare the calculated heat generated in the application to the unit ratings using the heat dissipation curves. Select the appropriate unit that has adequate heat dissipation ability.

## Heat Dissipation Curves

### Size 50

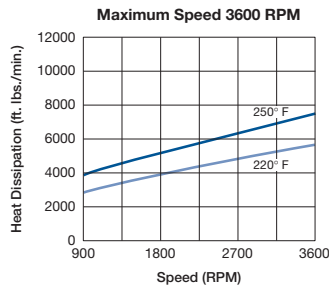

### Size 100/180

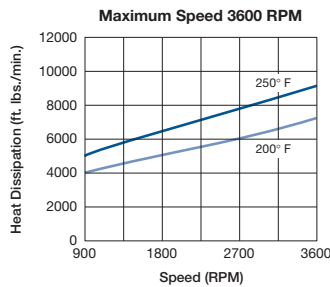

### Size 210/215

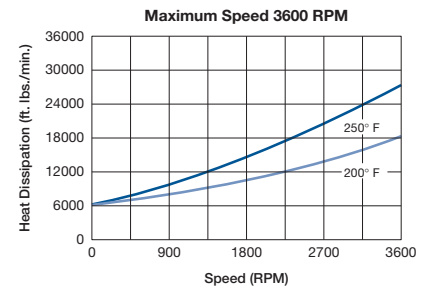

## b. Torque Sizing

For most applications, the correct size clutch/brake can be selected from the Horsepower vs. Shaft Speed chart.

Determine the motor horsepower and the RPM at the clutch/brake. The correct size unit is shown at the intersection of horsepower and shaft speed.

If the static torque requirements are known, refer to the Specifications Table to select a unit.

For some applications, the torque requirement is determined by the time allowed to accelerate and decelerate the load. (This time is generally specified in milliseconds.) For these applications, it is necessary to determine the torque requirement based on load inertia and the time allowed for engagement.

The torque requirements are calculated as follows:

$$T = (WR2 \times N) / (308 \times t)$$

where:

$$T = \text{Average Dynamic Torque (lb. ft.)}$$

WR2 = Total reflected inertia at the clutch/brake shaft. Include the clutch/brake output inertia. (lb. ft.2)

N = Speed in revolutions per minute (RPM)

t = Time allowed for the engagement (sec)

## C-face Clutch/Power-on Brake Dynamic Curves

### Size 50

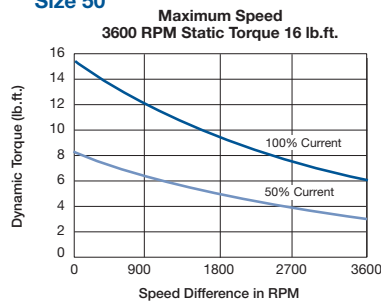

### Size 100/180

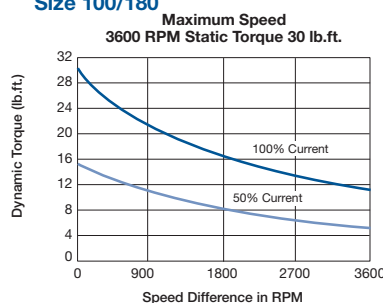

### Size 210/215

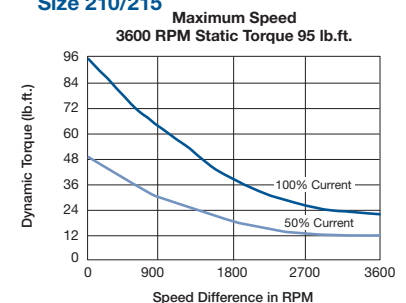

# EM Series Electro Module

## Specifications (Blue shaded areas indicate GEN 2 design)

EM Size	Static Torque lb. ft.	Maximum RPM	Voltage D.C.
50	16	3600	6, 24, or 90
100	30	3600	6, 24, or 90
180	30	3600	6, 24, or 90
210	95	3600	6, 24, or 90
215	95	3600	90

### 3. Accessories

Warner Electric Electro Modules can be fitted with several accessories to extend their capacity and ease of mounting.

#### a. Conduit Box

NEMA 4 and UL listed, available in standard and washdown versions.



#### b. Mounting Brackets

Two styles of mounting brackets are available for simplified installation.

The base mount is used with the 20/30 and 30/40 configurations. A motor mount is also available and provides sturdy support for 20, 10/20 and 10/40 units and motor.

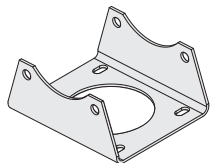

Base Mount

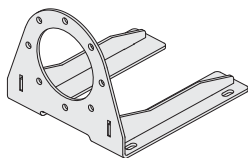

Motor Mount

For 50, 100 & 180 sizes

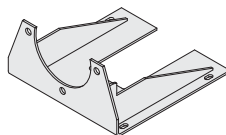

Motor Mount

For 210 & 215 sizes

#### c. Cover Kit – For sizes 50, 100 & 180



Each cover kit includes two (2) vent covers, two (2) gaskets and four (4) screws needed to convert a vented design into an enclosed design. For brake only modules, a cover plate is included to enclose the back of the brake.

### 4. Select Control

Warner Electric manufactures clutch/brake controls to meet several system functions including:

- On/Off
- Torque adjust
- Over excitation
- Position loop

Many requirements beyond function can impact control selection. See the Controls Section on page 201.

## Ordering Information

### Part Numbers

(Blue shaded areas indicate GEN 2 design)

Only 50, 100, and 180 sizes of the models listed will be converted to the new GEN 2 design. 210 and 215 sizes will continue to be offered in the original design and will not be converted.

Model No.	Voltage D.C.	GEN 2 Part No.	Original Part No.
<b>10 Motor Clutch Module</b>			
EM-50-10	6	5370-270-201	5370-270-020
EM-50-10	24	5370-270-203	5370-270-030
EM-50-10	90	5370-270-204	5370-270-015
EM-100-10	6	5370-270-206	5370-270-045
EM-100-10	24	5370-270-208	5370-270-056
EM-100-10	90	5370-270-209	5370-270-046
EM-180-10	6	5370-270-211	5370-270-021
EM-180-10	24	5370-270-213	5370-270-055
EM-180-10	90	5370-270-214	5370-270-017
EM-210-10	6		5371-270-011
EM-210-10	24		5371-270-027
EM-210-10	90		5371-270-009

<b>20 Brake Module</b>			
EM-50-20	6	5370-169-201	5370-169-043
EM-50-20	24	5370-169-203	5370-169-045
EM-50-20	90	5370-169-204	5370-169-042
EM-100-20	6	5370-169-206	5370-169-040
EM-100-20	24	5370-169-208	5370-169-072
EM-100-20	90	5370-169-209	5370-169-041
EM-180-20	6	5370-169-211	5370-169-050
EM-180-20	24	5370-169-213	5370-169-071
EM-180-20	90	5370-169-214	5370-169-051
EM-210-20	6		5371-169-022
EM-210-20	24		5371-169-034
EM-210-20	90		5371-169-023
EM-215-20	90		5371-169-076

<b>20MB Motor Brake</b>			
EM-50-20MB	6	5370-169-216	5370-169-047
EM-50-20MB	24	5370-169-218	5370-169-062
EM-50-20MB	90	5370-169-219	5370-169-048
EM-180-20MB	6	5370-169-221	5370-169-053
EM-180-20MB	24	5370-169-223	5370-169-073
EM-180-20MB	90	5370-169-224	5370-169-054
EM-210-20MB	6		5371-169-025
EM-210-20MB	24		5371-169-035
EM-210-20MB	90		5371-169-026

<b>30 Input Clutch Module</b>			
EM-50-30	6	5370-270-216	5370-270-019
EM-50-30	24	5370-270-218	5370-270-052
EM-50-30	90	5370-270-219	5370-270-016
EM-100-30	6	5370-270-221	5370-270-047
EM-100-30	24	5370-270-223	5370-270-054
EM-100-30	90	5370-270-224	5370-270-048
EM-180-30	6	5370-270-226	5370-270-049
EM-180-30	24	5370-270-228	5370-270-053
EM-180-30	90	5370-270-229	5370-270-050
EM-210-30	6		5371-270-023
EM-210-30	24		5371-270-026
EM-210-30	90		5371-270-024

Model No.	Voltage D.C.	GEN 2 Part No.	Original Part No.
<b>40 Output Clutch Module</b>			
EM-50-40		5370-536-200	5370-536-008
EM-100-40		5370-536-201	5370-536-007
EM-180-40		5370-536-202	5370-536-009
EM-210-40			5371-536-005

### Accessories

Description	EM Size	Part No.
Conduit Box	All sizes	5370-101-042
Base Mount Kit for 2030, 3040	50/100	5370-101-004
	180	5370-101-002
	210/215	5371-101-001
Motor Mount Kit for 20, 1020, 1040	50/100	5370-101-078
	180	5370-101-079
	210/215	5371-101-012
Cover Kit	50/100/180	5370-101-076
	50/100/180 (20 or 20MB)	5370-101-082

### How to Order

#### Motor or Reducer Mounted

Simply combine the size number with the configuration of the modular combination from page 25. Specify voltage. See chart for specific part numbers. Power-off brake Electro Modules are found on page 106. Order optional conduit box if desired.

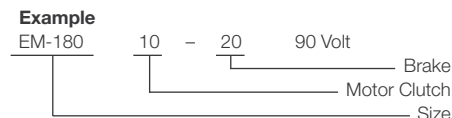

#### Base Mounted

Simply combine the size number with the configuration of the modular combination from page 25. Specify voltage. See chart for specific part numbers. Power-off brake Electro Modules are found on page 106. Order optional conduit box if desired.

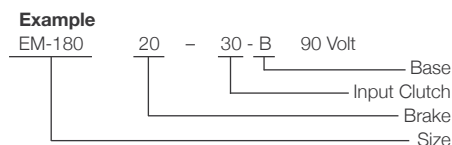

Select Appropriate Power Supply/Control. See the Controls Section beginning on page 201.

# EM Series Electro Module

## 10 Motor Clutch Module

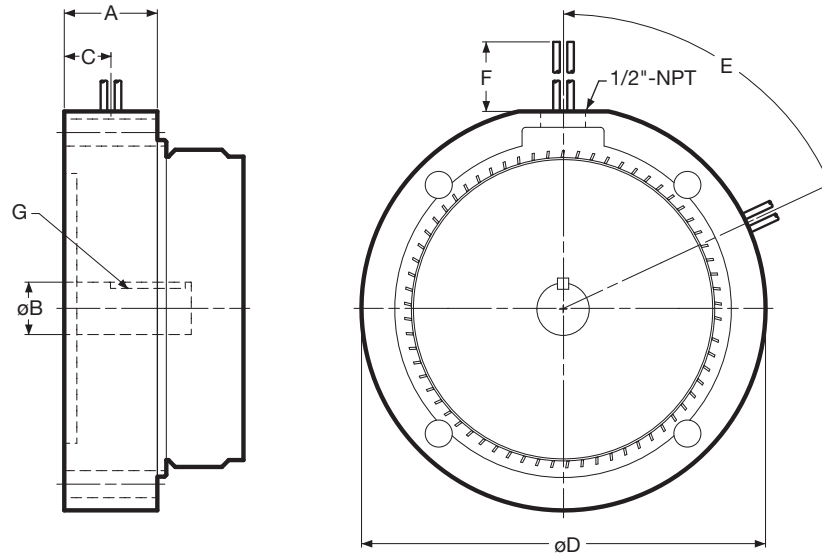

### Dimensions (Blue shaded areas indicate GEN 2 design)

Size	A	B	C	D	E	F	G
50	1.555	.625	.780	6.750	0°	36	3/16 x 3/16
100	1.555	.625	.780	6.750	0°	36	3/16 x 3/16
180	1.555	.875	.780	6.750	0°	36	3/16 x 3/16
210	1.313	1.125	.700	9.250	65°	36	1/4 x 1/4

### Specifications (Blue shaded areas indicate GEN 2 design)

Model Size	Voltage DC	Static Torque lb. ft.	Max. RPM	Inertia-WR <sup>2</sup> (lb.ft. <sup>2</sup> )	Weight (lbs)	NEMA Frame Size
50	6, 24, 90	16	3600	.020	6.4	56C/48Y*
100	6, 24, 90	30	3600	.046	7.6	56C/48Y**
180	6, 24, 90	30	3600	.046	7.6	182C/143TC 184C/145TC
210	6, 24, 90	95	3600	.188	9.1	213C/182TC 215C/184TC

\* For 56C/48Y Frame motors 3/4 HP and smaller the UM-100 size may be used where extended life is desirable.

\*\* UM-100 size is recommended for motors 1 HP and larger.

For standard NEMA frame dimensions, see page 187.

Only 50, 100, and 180 sizes of the models listed will be converted to the new GEN 2 design. 210 size will continue to be offered in the original design and will not be converted.



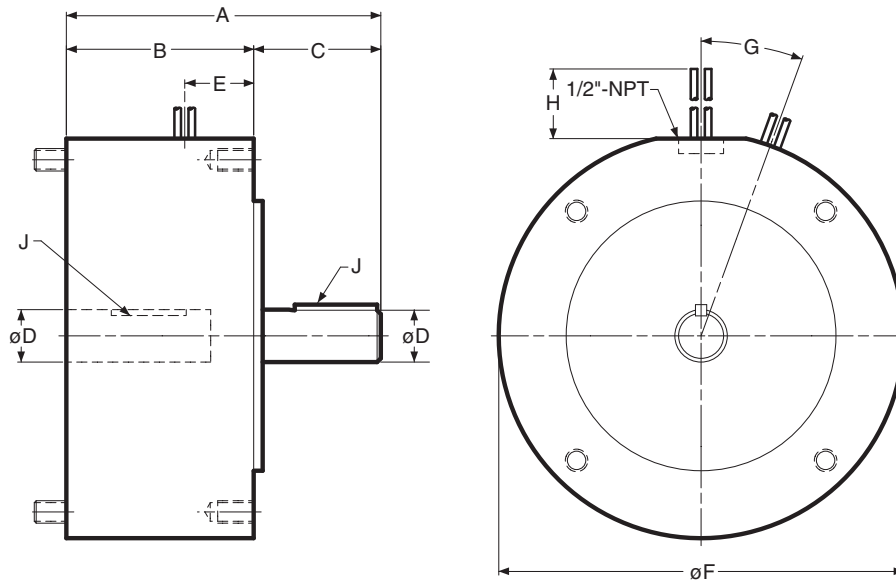

### Dimensions (Blue shaded areas indicate GEN 2 design)

Size	A	B	C	D	E	F	G	H	J
50	5.165	3.125	2.040	.625	1.150	6.750	0°	36	3/16 x 3/16
100	5.186	3.125	2.061	.625	1.150	6.750	0°	36	3/16 x 3/16
180	5.246	3.125	2.121	.875	1.150	6.750	0°	36	3/16 x 3/16
210	7.578	4.609	2.500	1.125	1.812	9.250	20°	36	1/4 x 1/4
215	8.078	4.609	3.000	1.375	1.812	9.250	20°	36	5/16 x 5/16

### Specifications (Blue shaded areas indicate GEN 2 design)

Model Size	Voltage DC	Static Torque lb. ft.	Max. RPM	Armatures	Inertia-WR <sup>2</sup> Arm. Hub	Shaft	Weight (lbs)	NEMA Frame Size
50	6, 24, 90	16	3600	.014	.002	.001	9.2	56C/48Y*
100	6, 24, 90	30	3600	.036	.003	.002	11.2	56C/48Y**
180	6, 24, 90	30	3600	.036	.003	.002	11.2	182C/143TC 184C/145TC
210	6, 24, 90	95	3600	.162	.021	.017	21.5	213C/182TC 215C/184TC
215	90	95	3600	.162	.021	.019	22	213TC/215TC***

\* For 56C/48Y Frame motors 3/4 HP and smaller the EM-100 size may be used where extended life is desirable.

\*\* EM-100 size is recommended for motors 1 HP and larger.

\*\*\* For 7-1/2 HP max.

For standard NEMA frame dimensions, see page 187.

**Only 50, 100, and 180 sizes of the models listed will be converted to the new GEN 2 design. 210 and 215 sizes will continue to be offered in the original design and will not be converted.**



# EM Series Electro Module

## 20MB Motor Brake Module

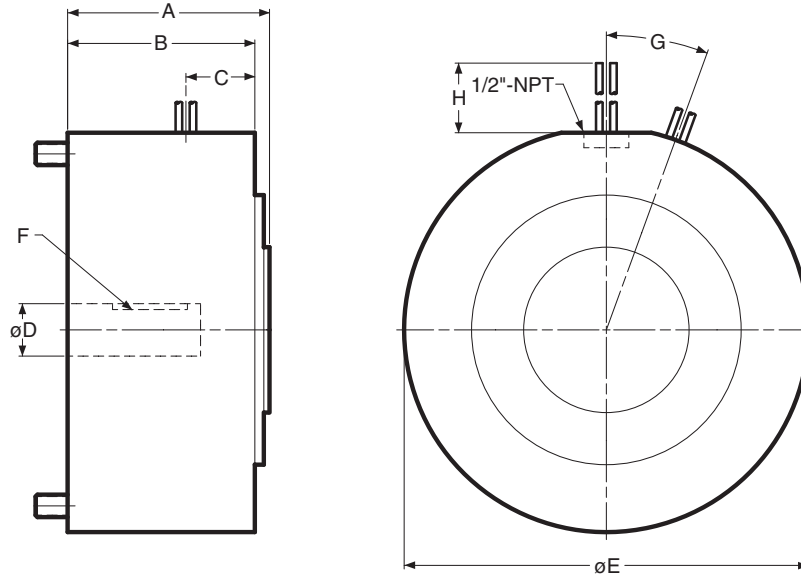

### Dimensions (Blue shaded areas indicate GEN 2 design)

Size	A	B	C	D	E	F	G	H
50	3.368	3.125	1.150	.625	6.750	3/16 x 3/16	0°	36
180	3.368	3.125	1.150	.875	6.750	3/16 x 3/16	0°	36
210	5.150	4.610	1.812	1.125	9.250	1/4 x 1/4	20°	36

### Specifications (Blue shaded areas indicate GEN 2 design)

Model Size	Voltage DC	Static Torque lb. ft.	Max. RPM	Armatures	Inertia-WR <sup>2</sup> Arm. Hub	Input Hub	Weight (lbs)	NEMA Frame Size
50	6, 24, 90	16	3600	.014	.002	.001	9.2	56C/48Y*
180	6, 24, 90	30	3600	.036	.003	.002	11.2	182C/143TC 184C/145TC
210	6, 24, 90	95	3600	.162	.021	.017	21.5	213C/182TC 215C/184TC

\*For 56C/48Y Frame motors 3/4 HP and smaller the EM-100 size may be used where extended life is desirable.

For standard NEMA frame dimensions, see page 187.

Only 50 and 180 sizes of the models listed will be converted to the new GEN 2 design. 210 size will continue to be offered in the original design and will not be converted.

# EM Series Electro Module

## 30 Input Clutch Module

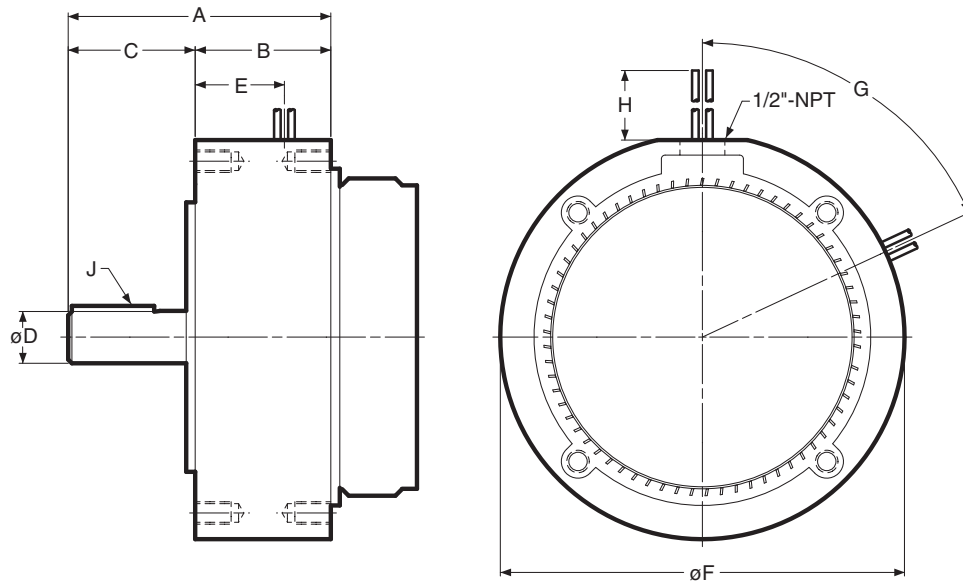

### Dimensions (Blue shaded areas indicate GEN 2 design)

Size	A	B	C	D	E	F	G	H	J
50	4.327	2.265	2.040	.625	1.490	6.750	0°	36	3/16 x 3/16
100	4.326	2.265	2.061	.625	1.490	6.750	0°	36	3/16 x 3/16
180	4.386	2.265	2.121	.875	1.490	6.750	0°	36	3/16 x 3/16
210	5.391	2.438	2.500	1.125	1.812	9.250	65°	36	1/4 x 1/4

### Specifications (Blue shaded areas indicate GEN 2 design)

Model Size	Voltage DC	Static Torque lb. ft.	Max. RPM	Inertia-WR <sup>2</sup>		Weight (lbs)	NEMA Frame Size
				Rotor	Shaft		
50	6, 24, 90	16	3600	.020	.001	9.2	56C/48Y*
100	6, 24, 90	30	3600	.046	.002	10.5	56C/48Y**
180	6, 24, 90	30	3600	.046	.002	10.5	182C/143TC 184C/145TC
210	6, 24, 90	95	3600	.188	.017	19.8	213C/182TC 215C/184TC

\* For 56C/48Y Frame motors 3/4 HP and smaller the EM-100 size may be used where extended life is desirable.

\*\* EM-100 size is recommended for motors 1 HP and larger.

For standard NEMA frame dimensions, see page 187.

Only 50, 100, and 180 sizes of the models listed will be converted to the new GEN 2 design. 210 size will continue to be offered in the original design and will not be converted.

# EM Series Electro Module

## 40 Output Clutch Module

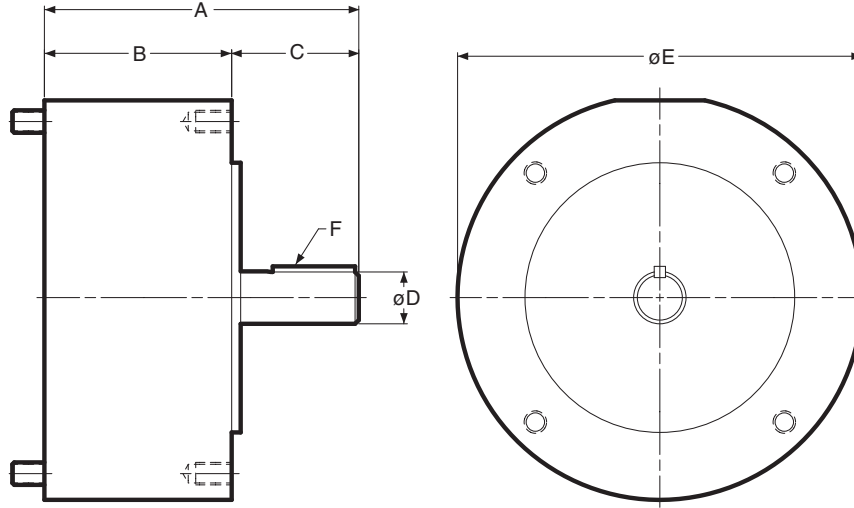

### Dimensions (Blue shaded areas indicate GEN 2 design)

Size	A	B	C	D	E	F
50	5.165	3.125	2.040	.625	6.750	3/16 x 3/16
100	5.186	3.125	2.061	.625	6.750	3/16 x 3/16
180	5.246	3.125	2.121	.875	6.750	3/16 x 3/16
210	7.578	4.609	2.500	1.125	9.250	1/4 x 1/4

### Specifications (Blue shaded areas indicate GEN 2 design)

Model Size	Voltage DC	Static Torque lb. ft.	Max. RPM	Armatures	Inertia-WR <sup>2</sup>		Weight (lbs)	NEMA Frame Size
					Arm. Hub	Shaft		
50	6, 24, 90	16	3600	.007	.002	.001	7.6	56C/48Y*
100	6, 24, 90	30	3600	.018	.003	.002	9.0	56C/48Y**
180	6, 24, 90	30	3600	.018	.003	.002	9.0	182C/143TC 184C/145TC
210	6, 24, 90	95	3600	.181	.021	.017	15.2	213C/182TC 215C/184TC

\* For 56C/48Y Frame motors 3/4 HP and smaller the EM-100 size may be used where extended life is desirable.

\*\* EM-100 size is recommended for motors 1 HP and larger.

For standard NEMA frame dimensions, see page 187.

Only 50, 100, and 180 sizes of the models listed will be converted to the new GEN 2 design. 210 size will continue to be offered in the original design and will not be converted.

# EM Series Electro Module

## EM-10/20 Motor Clutch/Brake Combination

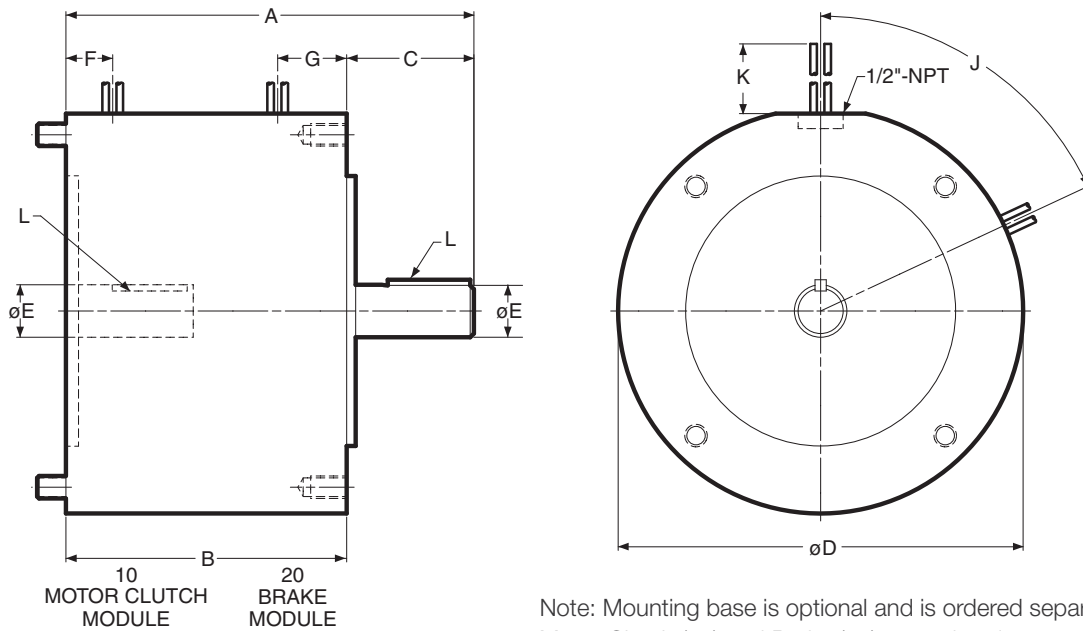

Note: Mounting base is optional and is ordered separately. Motor Clutch (10) and Brake (20) are ordered separately.

### Dimensions (Blue shaded areas indicate GEN 2 design)

Size	A	B	C	D	E	F	G	J	K	L	NEMA Frame Size
50	6.720	4.680	2.040	6.750	.625	.780	1.150	0°	36	3/16 x 3/16	56C/48Y*
100	6.741	4.680	2.061	6.750	.625	.780	1.150	0°	36	3/16 x 3/16	56C/48Y**
180	6.801	4.680	2.121	6.750	.875	.780	1.150	0°	36	3/16 x 3/16	182C/143TC 184C/145TC
210	8.891	5.922	2.500	9.250	1.125	.700	1.812	65°	36	1/4 x 1/4	213C/182TC 215C/184TC

\* For 56C/48Y Frame motors 3/4 HP and smaller the EM-100 size may be used where extended life is desirable.

\*\* EM-100 size is recommended for motors 1 HP and larger.

For standard NEMA frame dimensions, see page 187.

### Motor Mount (M) Dimensions (Blue shaded areas indicate GEN 2 design)

For use with 1020, 1040, 20, 20 FBB and 1020 FBC Combinations.

Size	R	S	T	U	V	W	Part No.
50/100	9.250	8.250	10.500	8.000	3.500	.800 x .406	5370-101-078
180	9.250	8.250	10.500	8.000	4.500	.800 x .406	5370-101-079
210/215	11.500	10.500	12.000	9.000	5.250	.750 x .409	5371-101-012

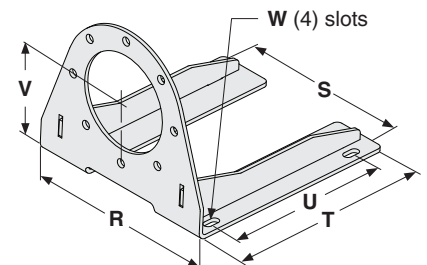

Only 50, 100, and 180 sizes of the models listed will be converted to the new GEN 2 design. 210 size will continue to be offered in the original design and will not be converted.

# EM Series Electro Module

## EM-10/40 Motor Clutch/Output Clutch Combination

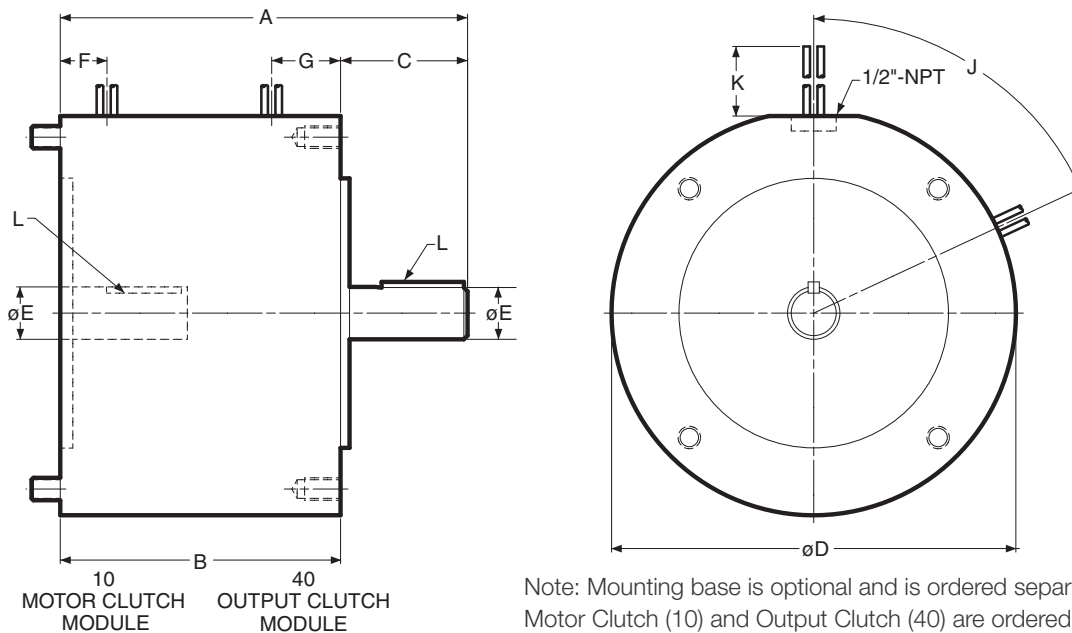

### Dimensions (Blue shaded areas indicate GEN 2 design)

Size	A	B	C	D	E	F	G	J	K	L	NEMA Frame Size
50	6.720	4.680	2.040	6.750	.625	.780	1.150	0°	36	3/16 x 3/16	56C/48Y*
100	6.741	4.680	2.061	6.750	.625	.780	1.150	0°	36	3/16 x 3/16	56C/48Y**
180	6.801	4.680	2.121	6.750	.875	.780	1.150	0°	36	3/16 x 3/16	182C/143TC 184C/145TC
210	8.891	5.922	2.500	9.250	1.125	.700	1.812	65°	36	1/4 x 1/4	213C/182TC 215C/184TC

\* For 56C/48Y Frame motors 3/4 HP and smaller the EM-100 size may be used where extended life is desirable.  
 \*\* EM-100 size is recommended for motors 1 HP and larger.

For standard NEMA frame dimensions, see page 187.

### Motor Mount (M) Dimensions (Blue shaded areas indicate GEN 2 design)

For use with 1020, 1040, 20, 20 FBB and 1020 FBC Combinations.

Size	R	S	T	U	V	W	Part No.
50/100	9.250	8.250	10.500	8.000	3.500	.800 x .406	5370-101-078
180	9.250	8.250	10.500	8.000	4.500	.800 x .406	5370-101-079
210/215	11.500	10.500	12.000	9.000	5.250	.750 x .409	5371-101-012

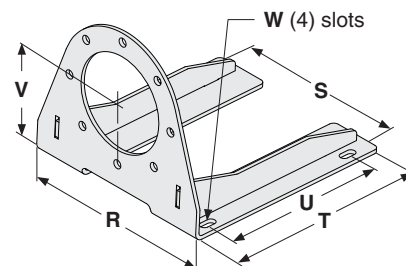

Only 50, 100, and 180 sizes of the models listed will be converted to the new GEN 2 design.  
 210 size will continue to be offered in the original design and will not be converted.

# EM Series Electro Module

## EM-20/30 Brake/Input Clutch Combination EM-20/30-B Brake/Input Clutch Combination – Base Mounted

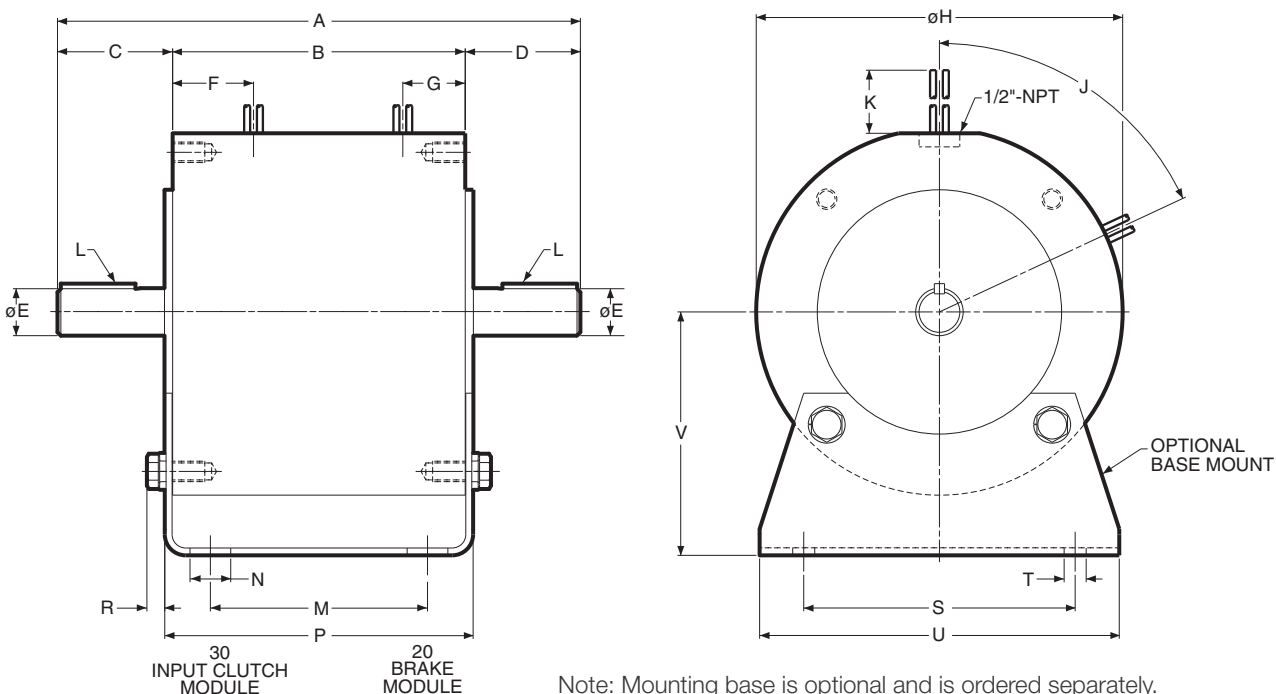

Note: Mounting base is optional and is ordered separately.  
Input Clutch (30) module and Brake Module (20) are ordered separately.

### Dimensions (Blue shaded areas indicate GEN 2 design)

Size	A	B	C	D	E	F	G	H	J	K	L
50	9.492	5.390	2.062	2.040	.625	1.490	1.150	6.750	0°	36	3/16 x 3/16
100	9.512	5.390	2.061	2.061	.625	1.490	1.150	6.750	0°	36	3/16 x 3/16
180	9.632	5.390	2.121	2.121	.875	1.490	1.150	6.750	0°	36	3/16 x 3/16
210	12.969	7.719	2.500	2.500	1.125	1.812	1.812	9.250	65°	36	1/4 x 1/4

Size	M	N	P	R	S	T	U	V
50	4.000	.800	5.680	.329	5.000	.406	6.000	3.500
100	4.000	.800	5.680	.329	5.000	.406	6.000	3.500
180	4.000	.750	5.680	.329	5.000	.406	6.625	4.500
210	6.000	.750	8.260	.437	7.750	.534	9.000	5.250

For standard NEMA frame dimensions, see page 187.

Only 50, 100, and 180 sizes of the models listed will be converted to the new GEN 2 design.  
210 size will continue to be offered in the original design and will not be converted.

# EM Series Electro Module

## EM-30/40 Input Clutch/Output Clutch Combination

## EM-30/40-B Input Clutch/Output Clutch Combination – Base Mounted

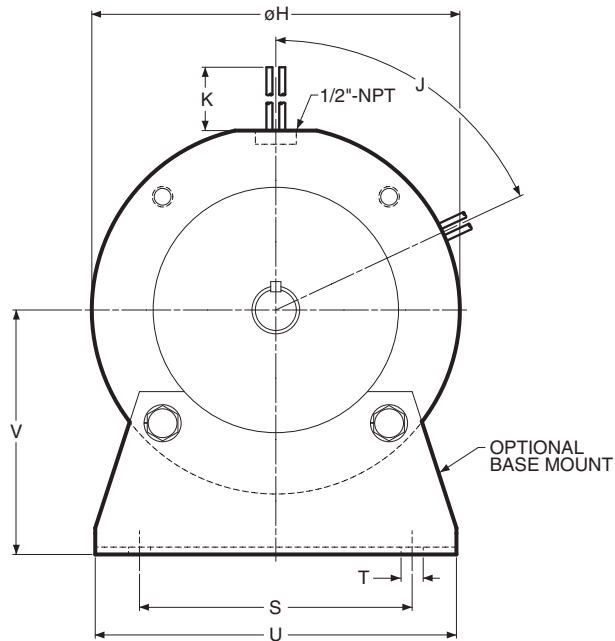
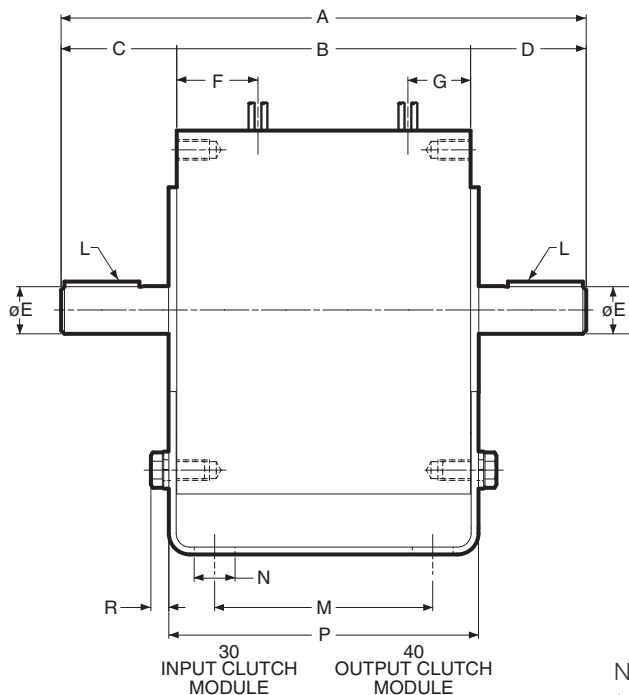

Note: Mounting base is optional and is ordered separately. Input Clutch (30) module and Output Clutch (40) are ordered separately.

### Dimensions (Blue shaded areas indicate GEN 2 design)

Size	A	B	C	D	E	F	G	H	J	K	L
50	9.492	5.390	2.062	2.040	.625	1.490	1.150	6.750	0°	36	3/16 x 3/16
100	9.512	5.390	2.061	2.061	.625	1.490	1.150	6.750	0°	36	3/16 x 3/16
180	9.632	5.390	2.121	2.121	.875	1.490	1.150	6.750	0°	36	3/16 x 3/16
210	12.969	7.719	2.500	2.500	1.125	1.812	1.812	9.250	65°	36	1/4 x 1/4

Size	M	N	P	R	S	T	U	V
50	4.000	.800	5.680	.329	5.000	.406	6.000	3.500
100	4.000	.800	5.680	.329	5.000	.406	6.000	3.500
180	4.000	.750	5.680	.329	5.000	.406	6.625	4.500
210	6.000	.750	8.260	.437	7.750	.534	9.000	5.250

For standard NEMA frame dimensions, see page 187.

Only 50, 100, and 180 sizes of the models listed will be converted to the new GEN 2 design. 210 size will continue to be offered in the original design and will not be converted.



# Enclosed Electro Module

## Contamination-Proof Design

Clean, quiet, operation. Nothing can get in, nothing can get out. Enclosed design eliminates damage to the working components. Prevents friction wear particles from escaping.

### Totally Enclosed Version

The Enclosed Electro Module packages the hardworking components from EM products into a totally enclosed housing. This rugged housing keeps wear particles in and contaminants out and provides quiet operation. When enclosed, units are suitable for most industrial applications and tolerate infrequent, light washing.

- Keeps contaminants out
- Keeps wear particles in
- Quiet operation
- Finned for heat dissipation
- UL listed when optional conduit box is installed

### To convert any Gen 2 Electro Module 50, 100, and 180 sizes to an enclosed model purchase optional Cover Kit

(part number 5370-101-076)

(part number 5370-101-082 for brake only)

### Enclosed Electro Module (10-20, 10-40, 20-30, 30-40)

An optional cover kit (part number 5370-101-076) can be purchased separately to enclose the open vents in the housing. Each cover kit includes two vent covers, two gaskets and four screws needed to convert a vented Electro Module to an enclosed design (non-washdown).



#### EUM-50

Maximum Speed 3600 RPM

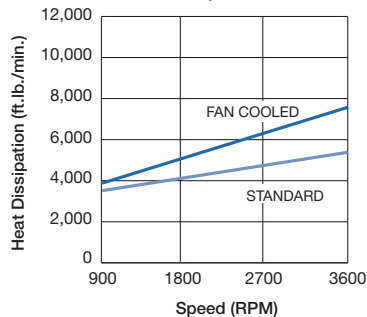

#### EUM-100/180

Maximum Speed 3600 RPM

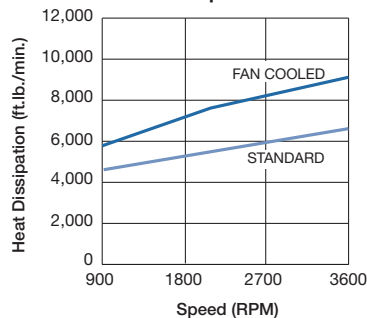

### Enclosed Electro Module-Brake Only (20 or 20MB)

An optional cover kit (part number 5370-101-082) can be purchased separately to enclose the open vents in the housing and a cover plate to close off the back of the module. Each cover kit includes two vent covers, two gaskets, four screws and one cover plate needed to convert a vented Electro Module 20 to an enclosed design (non-washdown).



#### NOTE:

Enclosed option is not available for existing 210 & 215 size Electro Modules (EM)