

EM VAR 04 | EMER VAR 04

Electro-Magnetic Single Disc Clutch & Brake Combination

Characteristics

- Electrically operated 24 VDC
- Single friction face
- Clutch activated by power on
- Brake activated by power on = **EM**
- Brake activated by power off = **EMER**
- Shaft on clutch side - hollow shaft on brake side
- Standard with lead termination or connector as option

Utilisation

- Coupling of a pulley or a shaft

Particularities

- For dry use
- Input with flange M2 or M3, output with flange M2 or M3

Adjustments

- No wear compensation required

Maintenance Manual

- SM 305

IEC Mounting Flanges

Permitted combinations and dimensions

Size	EM2	EMER2	EM3	EMER3	EM4	EMER4	EM5	EMER5	EM6	EMER6
Flange M1	115	X	X	-	-	-	-	-	-	-
	130	X	X	X	X	X	X	-	-	-
	165	-	-	X	X	X	X	X	-	-
	215	-	-	-	-	-	X	X	X	X
	265	-	-	-	-	-	-	-	X	X
Flange M2	115	X	X	-	-	-	-	-	-	-
	130	X	X	X	X	X	X	-	-	-
	165	-	-	X	X	X	X	X	-	-
	215	-	-	-	-	-	X	X	X	X
	265	-	-	-	-	-	-	-	X	X
Flange M3	75	X	X	X	X	-	-	-	-	-
	85	X	X	X	X	-	-	-	-	-
	100	-	-	X	X	X	X	-	-	-
	115	-	-	-	-	X	X	X	-	-
	130	-	-	-	-	-	-	X	X	-
	165	-	-	-	-	-	-	-	X	X
	215	-	-	-	-	-	-	-	X	X
Cover	X	X	X	X	X	X	X	X	X	X

Size with	75 EM2	75 EM3	85 EM2	85 EM3	100 EM3	100 EM4	115 EM2	115 EM4	115 EM5	130 EM2	130 EM3	130 EM4	130 EM5	165 EM3	165 EM4	165 EM5	165 EM6	215 EM5	215 EM6	265 EM6
Flange M1	L1	-	-	-	-	-	10	-	-	10	12	14	-	14	12	14	-	17	14	17
	N1 h8	-	-	-	-	-	95	-	-	110	110	110	-	130	130	130	-	180	180	230
	P1	-	-	-	-	-	140	-	-	160	160	160	-	200	200	200	-	250	300	300
	S1	-	-	-	-	-	115 Ax 09	-	-	-	130 Ax 09	130 Ax 09	-	165 Ax 011	165 Ax 011	165 Ax 011	-	215 Ax 014	215 Ax 014	265 Ax 014
	T1	-	-	-	-	-	3	-	-	3,5	3,5	3,5	-	3,5	3,5	3,5	-	4	4	4
Flange M2	L2	-	-	-	-	-	14	-	-	-	14	14	-	15,5	18	18	-	18	14	17
	N2+0,3/+0,2	-	-	-	-	-	95	-	-	-	110	110	-	130	130	130	-	180	180	230
	P2	-	-	-	-	-	140	-	-	-	160	160	-	200	200	200	-	250	300	300
	S2	-	-	-	-	-	115 4xM8	-	-	-	130 4xM8	130 4xM8	-	165 4xM10	165 4xM10	165 4xM10	-	215 4xM12	215 4xM12	265 4xM12
	T2	-	-	-	-	-	3,5	-	-	-	4	4	-	4	4	4	-	4,5	4,5	4,5
Flange M3	L3	15	15	15	15	16	16	-	15	15	-	-	-	16	-	-	-	22	-	22
	N3+0,3/+0,2	60	60	70	70	80	80	-	95	95	-	-	-	110	-	-	-	130	-	180
	P3	90	90	105	105	120	120	-	140	140	-	-	-	160	-	-	-	200	-	250
	S3	75 4x06	75 4x06	85 4x06	85 4x06	100 4x07	100 4x07	-	115 4x09	115 4x09	-	-	-	130 4x09	-	-	-	165 4x011	-	215 4x014
	T3	3	3	3	3	3	3	-	3,5	3,5	-	-	-	4	-	-	-	4	-	4,5

Electro-Magnetic Single Disc Clutch & Brake Combination

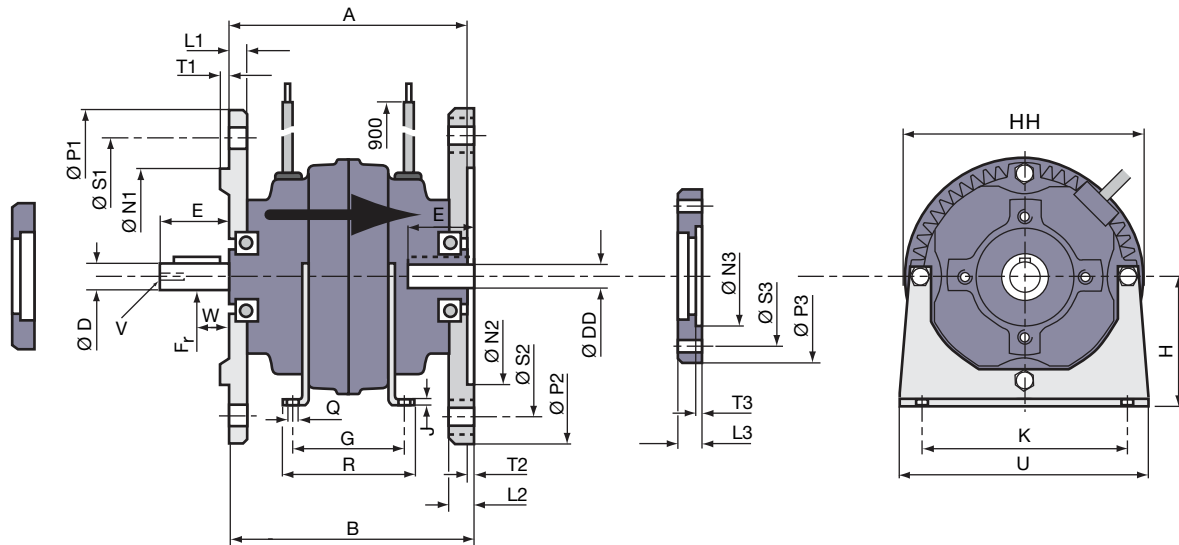

Cover or M1 Flange M1 or M3

Sizes		EM2	EMER2	EM3	EMER3	EM4	EMER4	EM5	EMER5	EM6	EMER6
Nom. Torque	[Nm]	7.5	4.5	15	9	25	14	50	28	130	75
Max. Speed	[min ⁻¹]	3600	3600	3600	3600	3600	3600	3600	3600	3600	3600
Power	P20 [24V] [W]	13	12	11	12	26	20	20	24	30	36
	A	136	147	144	155	160	171	170	181	230	241
	B	140	151	148	159	164	175	175	186	235	246
	D ⁶⁶ xE & DD ⁶⁷ xE	11x23 14x30	11x23 14x30	14x30 19x40	14x30 19x40	19x40 24x50	19x40 24x50	24x50 28x60	24x50 28x60	28x60 38x80	28x60 38x80
	G	90	101	105	116	117	128	124	135	160	171
	H	63	63	71	71	90	90	100	100	132	132
	HH	112	112	142	142	180	180	200	200	240	240
	J	3	3	3	3	4	4	5	5	6	6
	K	100	100	112	112	140	140	160	160	216	216
	Q	7	7	9	9	10	10	12	12	12	12
	R	109	120	120	131	136	147	140	151	186	197
	U	116	116	144	144	170	170	200	200	264	264
	W	11	11	20	20	20	20	30	30	35	35
	X	100	100	110	110	122	122	-	-	-	-
Inertia	[kgm ²]	0,00011	0,00011	0,0003	0,0003	0,0008	0,0008	0,00018	0,00018	0,00085	0,00085
Coil Build up time	tb [s]	0,025	0,030	0,030	0,040	0,052	0,040	0,070	0,080	0,11	0,09
Coil Delay Time	td [s]	0,004	0,003	0,005	0,003	0,006	0,005	0,0012	0,008	0,02	0,01
Radial Load	Fr [N]	480	480	900	900	1450	1450	1850	1850	3000	3000
Weight	[kg]	2,9	2,9	4,0	4,0	7,0	7,0	11	11	23	23
Connection		Cable									

Keyway BS 4235
DIN 6885
NF E 22-175

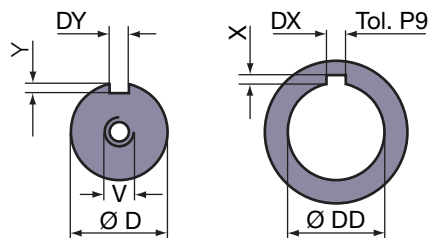

Option Connector



øD, øDD	11	14	19	24	28	38
DX x X	4 x 1,8	5 x 2,3	6 x 2,8	8 x 3,3	8 x 3,3	10 x 3,3
DY x Y	4 x 2,5	5 x 3	6 x 3,5	8 x 4	8 x 4	10 x 5
V	M4 x 10	M5 x 12	M6 x 16	M8 x 19	M10 x 22	M12 x 28