

# Rodless cylinders with slide guide

Series ZX-Ø-SG

G1/8 to G3/8 • piston Ø 25 to 63 mm

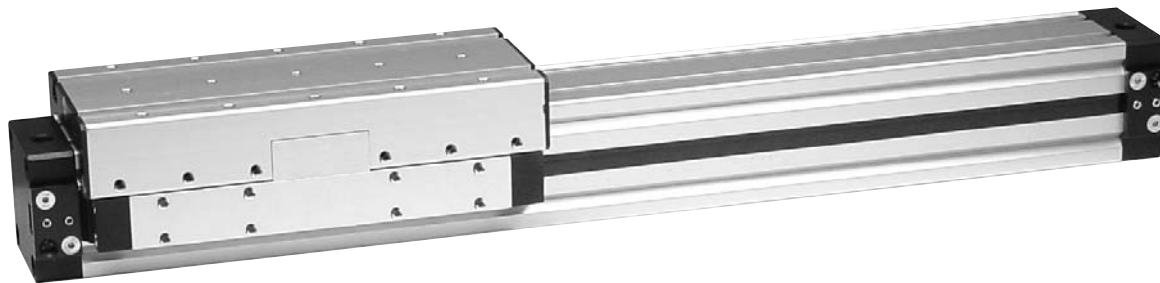
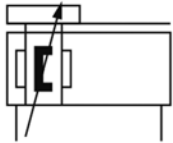

## Order code

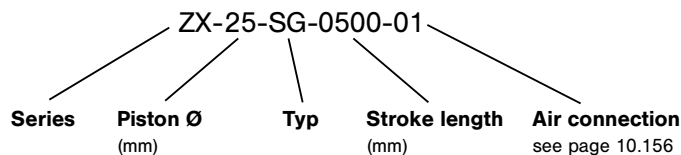

## Design and function

Double acting rodless cylinder with adjustable cushion and permanent magnet. Series SG incorporates an adjustable guide system for medium loads.

The sensors can be installed directly into the grooves of the aluminum profile.

Cylinders of this series are available in explosion proof design in accordance with 2014/34/EU (ATEX). For further details see chapter 13 of this catalogue

Order number Please complete according to order code.	ZX-25-SG-...	ZX-32-SG-...	ZX-40-SG-...	ZX-50-SG-...	ZX-63-SG-...
<b>Piston Ø (mm)</b>	25	32	40	50	63
<b>Connection</b>	G1/8	G1/8	G1/4	G3/8	G3/8
<b>Cushioning length (mm)</b>	24	28	36	45	59
<b>Mass at 0 mm stroke</b>	1.31 kg (2.888 lbs.)	2.09 kg (4.608 lbs.)	3.58 kg (7.892 lbs.)	7.28 kg (16.049 lbs.)	11.02 kg (24.294 lbs.)
<b>additional mass per 100 mm</b>	0.30 kg (0.661 lb.)	0.39 kg (0.860 lb.)	0.52 kg (1.168 lbs.)	0.96 kg (2.116 lbs.)	1.32 kg (2.91 lbs.)
<b>Operating pressure</b>	1 ... 8 bar (14.5 ... 116 psi)				
<b>Temperature range</b>	- 10 °C ... + 70 °C (+ 14 °F ... + 158 °F)				
<b>Medium</b>	Compressed air in accordance with ISO 8573-1:2010, Class 7:2:4 – and free of aggressive additives. If speeds exceed 1 m/s (3.3 ft/s) lubricated air is recommended.				
<b>Stroke length</b>	arbitrary up to 6000 mm (arbitrary up to 236 in)		max. 5950 mm (max. 234 in)	max. 5910 mm (max. 232 in)	max. 5860 mm (max. 230 in)
<b>Materials</b>	Al (anodized), plastic Seals: NBR, PU				

# Rodless cylinders with slide guide

Series ZX-Ø-SG

G1/8 to G3/8 • piston Ø 25 to 63 mm

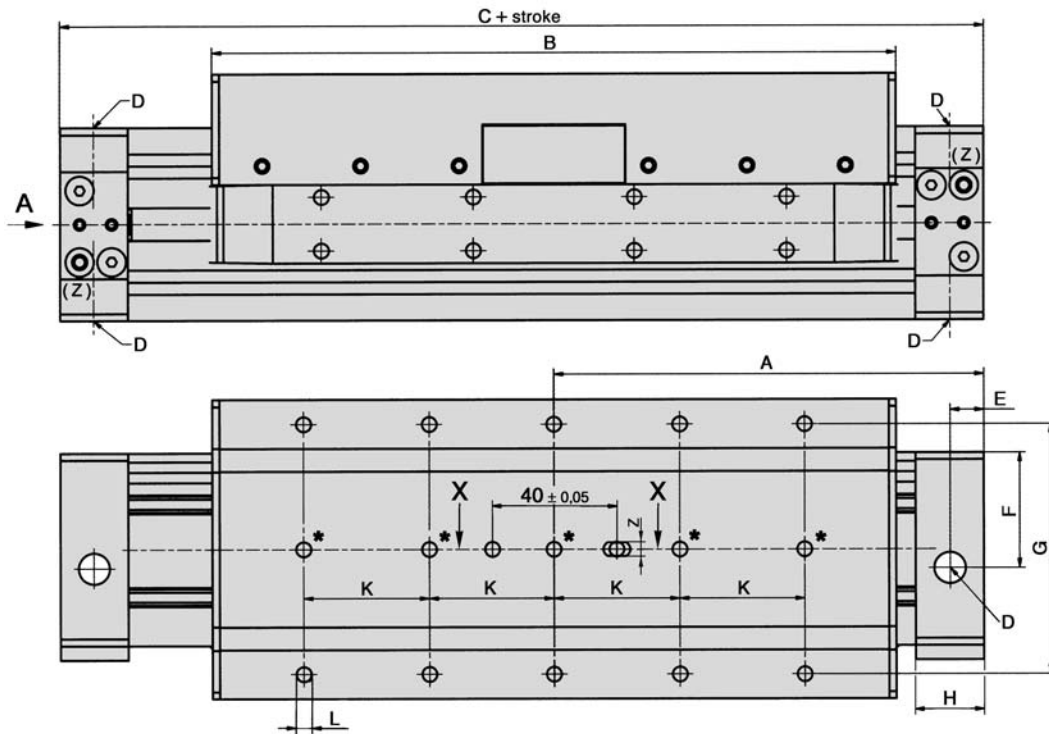

## cross section B-B

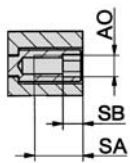

SA = Depth of thread  
SB = Length of hex.

## cross section X-X

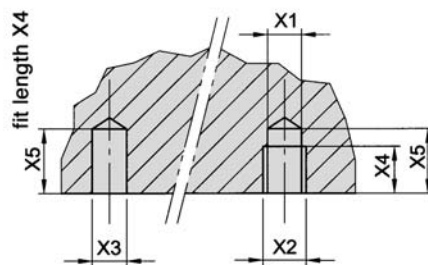

\* = Thread only in cylinder Ø 32 mm (depth of thread 9 mm).

(Z) = Cushion set screw.

Drawing shows pressure supply type -01 for air connection on both ends.

Other types see page 10.156.

## view A

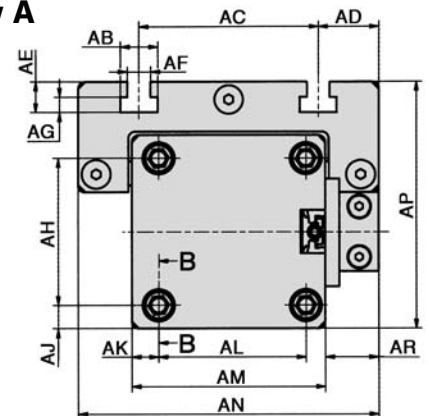

Piston Ø	A	B	C	D	E	F	G	H	K	L	AB	AC	AD	AE	AF	AG
25	100	159	200	G1/8	9.5	25	30	19	30	M5 x 8 mm deep	10.4	50	12.5	8.6	6.4	4.3
32	120	191	240	G1/8	9.5	32.3	70	19	35	M5 x 11mm deep*	10.4	50	16.9	8.6	6.4	4.3
40	150	246	300	G1/4	11.5	38.2	55	23	55	M6 x 12 mm deep	10.4	80	10	8.6	6.4	4.3
50	175	270	350	G3/8	17	59	42	30	50	M8 x 16 mm deep	10.4	94	23	8.6	6.4	4.3
63	200	320	400	G3/8	17	68.4	60	30	60	M8 x 16 mm deep	10.4	110	24	8.6	6.4	4.3

Piston Ø	AH	AJ	AK	AL	AM	AN	AO	AP	AR	SA	SB	Ø X1	X2	Ø X3	X4	X5	Z
25	36	4.5	4.5	36	45	75	M4	59	15	11	3	4	4.4 + 0.2	4 H7	4.5	5.5	4 + 0.02
32	41	6.5	7.5	41	54	83.8	M5	69	15	11	4	4	4.4 + 0.2	4 H7	7	8	4 + 0.02
40	49	7.5	7.5	49	64	100	M6	79	18	12	4	6	6.4 + 0.2	6 H7	7	8	6 + 0.02
50	65	12.5	12.5	65	90	133	M8	112.5	25	17	5	-	6.4 + 0.2	6 H7	3	3	6 + 0.02
63	78	14	14	78	106	150	M8	134.5	26	17	5	-	6.4 + 0.2	6 H7	6.5	6.5	6 + 0.02

# Rodless cylinders series ZX

Accessories



## Air connection for series ZX-Ø-S and ZX-Ø-K

### Option -01

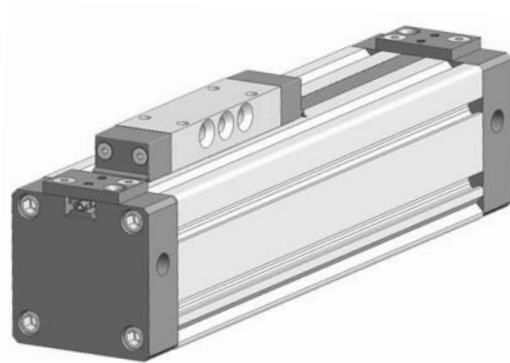
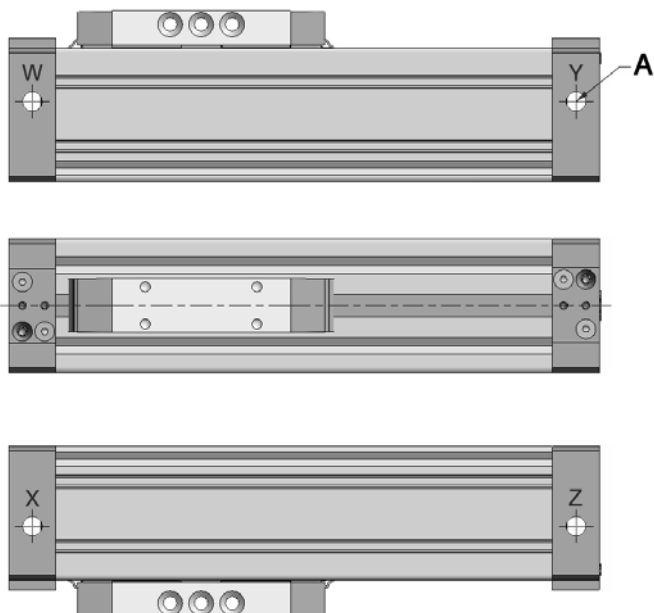

Option -01 cylinder comes with two pressure connections (W-X and Y-Z respectively) on each end. User is required to select one of two pressure connections on each end. Second port will require the installation of a sealing plug (2 plugs are supplied).

### Option -02

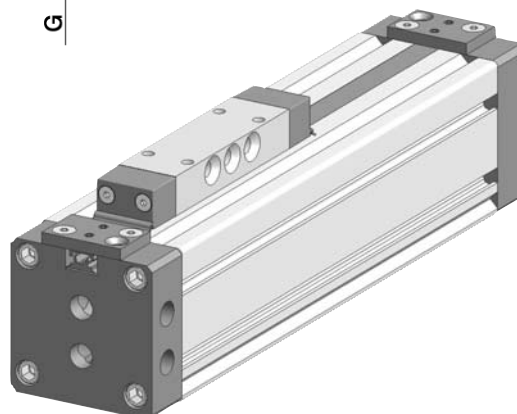
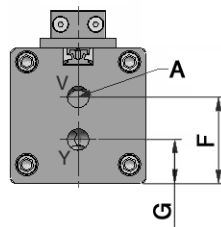
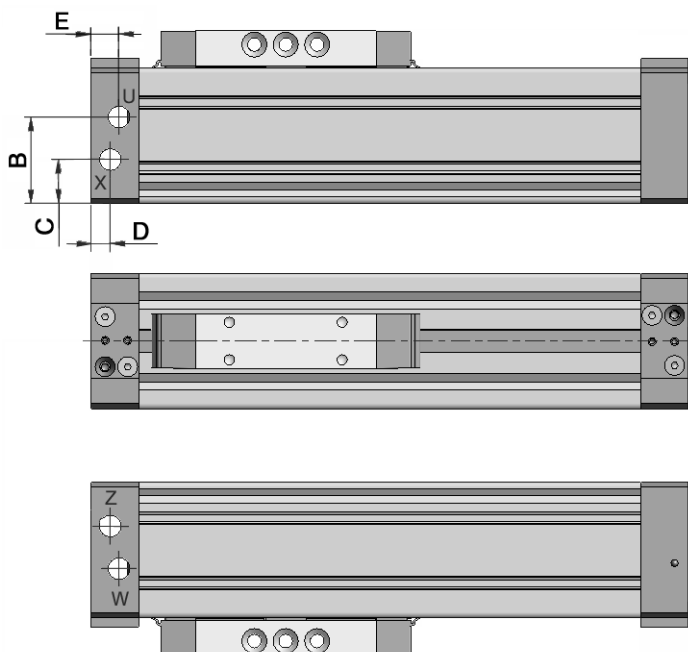

Cyl.-Ø	A	B	C	D	E	F	G
25	G1/8	28.5	13.5	8	11	29.5	13.5
32	G1/8	34.5	17.5	9.5	9.5	34.5	17.5
40	G1/4	42.5	20.5	11.5	11.5	38.2	15.5
50	G3/8	59	29	17	17	59	29.6
63	G3/8	68.4	34	17	17	68.4	34

One cylinder head is supplied with 6 ports (3 for each direction, U-V-W are for travel in one direction and X-Y-Z are for travel in the opposite direction). User is required to select one of three pressure connections for each direction. The second and third ports will require the installation of a sealing plug (4 plugs are supplied).

Ports V and Y must be plugged when using a head mount.

**Air connection options for series ZX-Ø-S and ZX-Ø-K**

**Option -04**

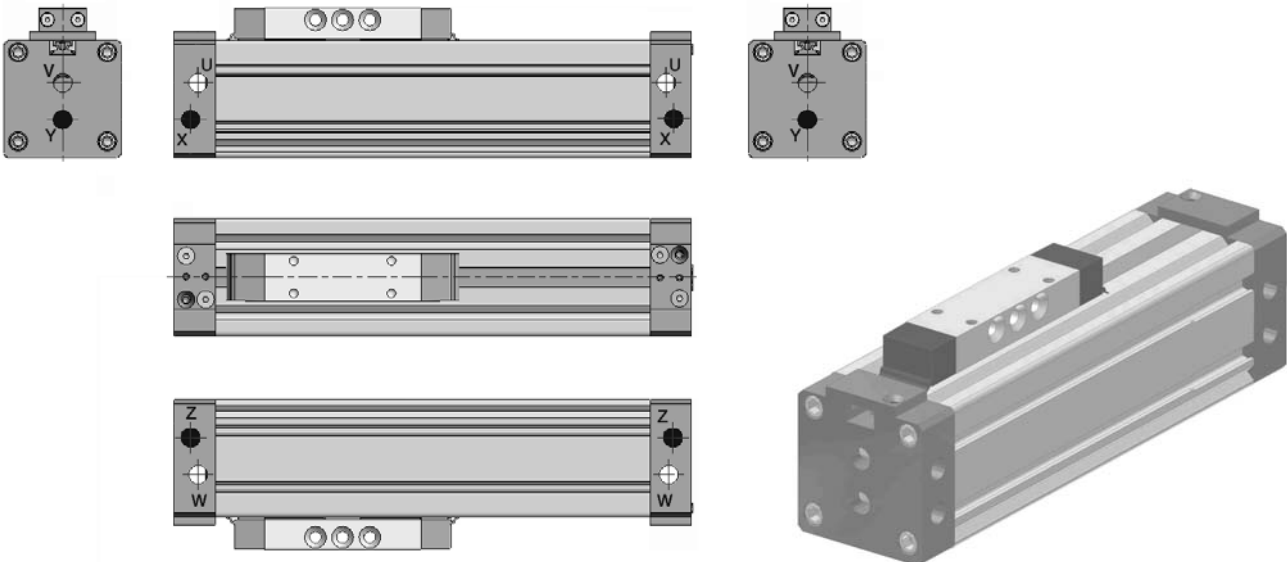

Option -04 enable to connect pressure at both face ends or one face and one side port. Therefore the head with 6 ports from option -02 is used at both ends. Now it is possible to use the upper ports (U-V-W). The lower ports (X-Y-Z) are plugged. This option is for using ports at both cylinder heads only. The dimensions are identical to option -02.

**Seal kit for series ZX**

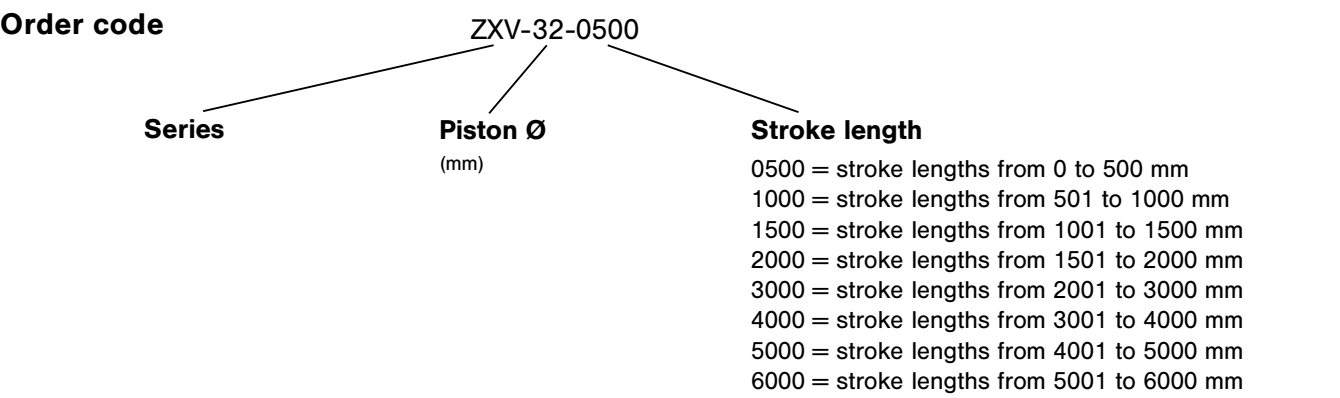

### Definition of forces and torques

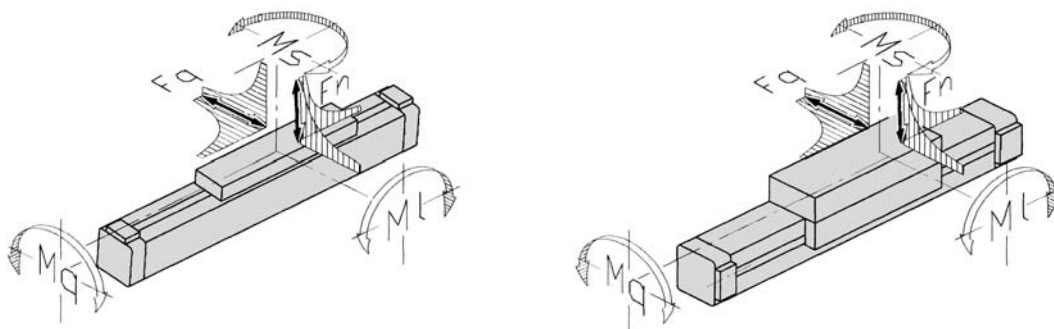

### Maximum Force and Torque Data

Type	Operating force*	Fn max.	Fq max.	Ml max.	Mq max.	Ms max.
ZX-25-S	255 N (57 lbf)	270 N (61 lbf)	-	13 Nm (9.59 ft. lbf.)	2.5 Nm (1.84 ft. lbf.)	11 Nm (8.11 ft. lbf.)
ZX-25-K	255 N (57 lbf)	270 N (61 lbf)	-	8 Nm (5.90 ft. lbf.)	2.0 Nm (1.47 ft. lbf.)	7 Nm (5.16 ft. lbf.)
ZX-25-SG	250 N (56 lbf)	580 N (130 lbf)	580 N (130 lbf)	23 Nm (17.0 ft. lbf.)	10.0 Nm (7.37 ft. lbf.)	23 Nm (17.0 ft. lbf.)
ZX-25-KG	250 N (56 lbf)	340 N (76 lbf)	340 N (76 lbf)	9 Nm (6.64 ft. lbf.)	5.0 Nm (3.69 ft. lbf.)	9 Nm (6.64 ft. lbf.)
ZX-25-SR	250 N (56 lbf)	850 N (191 lbf)	1300 N (292 lbf)	65 Nm (47.9 ft. lbf.)	35.0 Nm (25.8 ft. lbf.)	105 Nm (77.4 ft. lbf.)
ZX-25-KR	250 N (56 lbf)	850 N (191 lbf)	1300 N (292 lbf)	29 Nm (21.4 ft. lbf.)	35.0 Nm (25.8 ft. lbf.)	64 Nm (47.2 ft. lbf.)
ZX-32-S	420 N (94 lbf)	300 N (67 lbf)	-	30 Nm (22.1 ft. lbf.)	3.0 Nm (2.21 ft. lbf.)	24 Nm (17.7 ft. lbf.)
ZX-32-K	420 N (94 lbf)	300 N (67 lbf)	-	15 Nm (11.1 ft. lbf.)	3.0 Nm (2.21 ft. lbf.)	12 Nm (8.85 ft. lbf.)
ZX-32-SG	410 N (92 lbf)	850 N (191 lbf)	850 N (191 lbf)	33 Nm (24.3 ft. lbf.)	15.0 Nm (11.1 ft. lbf.)	33 Nm (24.3 ft. lbf.)
ZX-32-KG	410 N (92 lbf)	460 N (103 lbf)	460 N (103 lbf)	14 Nm (10.3 ft. lbf.)	6.5 Nm (4.79 ft. lbf.)	14 Nm (10.3 ft. lbf.)
ZX-32-SR	410 N (92 lbf)	900 N (202 lbf)	1500 N (337 lbf)	79 Nm (58.3 ft. lbf.)	40.0 Nm (29.5 ft. lbf.)	125 Nm (92.2 ft. lbf.)
ZX-32-KR	410 N (92 lbf)	900 N (202 lbf)	1500 N (337 lbf)	36 Nm (26.5 ft. lbf.)	40.0 Nm (29.5 ft. lbf.)	76 Nm (56.1 ft. lbf.)
ZX-40-S	655 N (147 lbf)	650 N (146 lbf)	-	60 Nm (44.2 ft. lbf.)	4.0 Nm (2.95 ft. lbf.)	54 Nm (39.8 ft. lbf.)
ZX-40-K	655 N (147 lbf)	650 N (146 lbf)	-	30 Nm (22.1 ft. lbf.)	4.0 Nm (2.95 ft. lbf.)	27 Nm (19.9 ft. lbf.)
ZX-40-SG	640 N (144 lbf)	1120 N (252 lbf)	1120 N (252 lbf)	60 Nm (44.2 ft. lbf.)	25.0 Nm (18.4 ft. lbf.)	60 Nm (44.2 ft. lbf.)
ZX-40-KG	640 N (144 lbf)	600 N (135 lbf)	600 N (135 lbf)	25 Nm (18.4 ft. lbf.)	11.0 Nm (8.11 ft. lbf.)	25 Nm (18.4 ft. lbf.)
ZX-40-SR	640 N (144 lbf)	1200 N (270 lbf)	2000 N (450 lbf)	190 Nm (140 ft. lbf.)	67.0 Nm (49.4 ft. lbf.)	118 Nm (87.0 ft. lbf.)
ZX-40-KR	640 N (144 lbf)	1200 N (270 lbf)	2000 N (450 lbf)	85 Nm (62.7 ft. lbf.)	67.0 Nm (49.4 ft. lbf.)	72 Nm (53.1 ft. lbf.)
ZX-50-S	1000 N (225 lbf)	800 N (180 lbf)	-	80 Nm (59.0 ft. lbf.)	17.0 Nm (12.5 ft. lbf.)	74 Nm (54.6 ft. lbf.)
ZX-50-K	1000 N (225 lbf)	800 N (180 lbf)	-	38 Nm (28.0 ft. lbf.)	17.0 Nm (12.5 ft. lbf.)	32 Nm (23.6 ft. lbf.)
ZX-50-SG	1000 N (225 lbf)	1550 N (348 lbf)	1500 N (337 lbf)	200 Nm (147.5 ft. lbf.)	70.0 Nm (51.6 ft. lbf.)	200 Nm (147.5 ft. lbf.)
ZX-50-KG	1000 N (225 lbf)	820 N (184 lbf)	800 N (180 lbf)	60 Nm (44.2 ft. lbf.)	40.0 Nm (29.5 ft. lbf.)	60 Nm (44.2 ft. lbf.)
ZX-50-SR	1000 N (225 lbf)	4100 N (922 lbf)	2000 N (450 lbf)	157 Nm (115.6 ft. lbf.)	45.0 Nm (33.1 ft. lbf.)	170 Nm (125.2 ft. lbf.)
ZX-50-KR	1000 N (225 lbf)	1800 N (405 lbf)	2000 N (450 lbf)	67 Nm (49.4 ft. lbf.)	45.0 Nm (33.1 ft. lbf.)	106 Nm (78.1 ft. lbf.)
ZX-63-S	1600 N (360 lbf)	1400 N (315 lbf)	-	110 Nm (81.0 ft. lbf.)	17.0 Nm (12.5 ft. lbf.)	100 Nm (73.7 ft. lbf.)
ZX-63-K	1600 N (360 lbf)	1400 N (315 lbf)	-	50 Nm (36.8 ft. lbf.)	17.0 Nm (12.5 ft. lbf.)	48 Nm (35.4 ft. lbf.)
ZX-63-SG	1600 N (360 lbf)	2000 N (450 lbf)	2000 N (450 lbf)	300 Nm (221.2 ft. lbf.)	102.0 Nm (75.2 ft. lbf.)	300 Nm (221.2 ft. lbf.)
ZX-63-KG	1600 N (360 lbf)	1100 N (247 lbf)	1100 N (247 lbf)	105 Nm (77.4 ft. lbf.)	56.0 Nm (41.3 ft. lbf.)	105 Nm (77.4 ft. lbf.)
ZX-63-SR	1600 N (360 lbf)	5000 N (1124 lbf)	2000 N (450 lbf)	196 Nm (144.4 ft. lbf.)	52.0 Nm (38.3 ft. lbf.)	208 Nm (153.2 ft. lbf.)
ZX-63-KR	1600 N (360 lbf)	2500 N (562 lbf)	2000 N (450 lbf)	99 Nm (72.9 ft. lbf.)	52.0 Nm (38.3 ft. lbf.)	134 Nm (98.7 ft. lbf.)

The mounting surface of the assembled mass should not exceed a straightness tolerance of 0.1 mm to avoid additional tension or clearance in the guiding system.

#### Complex loads

If more than one force and torque appear simultaneously, they have to be calculated by the formula:

$$\frac{F_n}{F_{n \max.}} + \frac{F_q}{F_{q \max.}} + \frac{M_l}{M_{l \max.}} + \frac{M_q}{M_{q \max.}} + \frac{M_s}{M_{s \max.}} \leq 1$$

Information on forces and torques refers to speeds for slide guides (series S, K, SG and KG) of  $\leq 0.2$  m/s (0.656 ft/s) and speeds for roller guides (series SR and KR) of  $\leq 2$  m/s (6.562 ft/s).

Where speeds exceed 0.2 m/s (0.656 ft/s) the permissible values of the slide guides are to be multiplied by the loading coefficient (see table on the right).

The information on torques refers to the center point of the slide which, in the case of the ZX-S and ZX-K cylinders, is the center of the tube. In versions with slide guides, the center point of the guide is in the slide.

\* Operating force at 6 bar (87 psi). The internal friction is considered.

#### Loading coefficient

V in m/s	V in ft/s	Factor
0.2	0.656	1
0.3	0.984	0.75
0.4	1.312	0.5
0.5	1.640	0.4
0.75	2.460	0.27
1	3.281	0.2

**Cushioning diagram**

The stroke end cushion must be adjusted to hitchless driving. If the application is out of the diagram range, an external shock absorber is required. The mounting position of shock absorbers must be close to the center of the mass.  
The data applies to a horizontal mounting position.

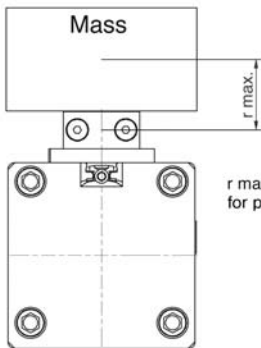
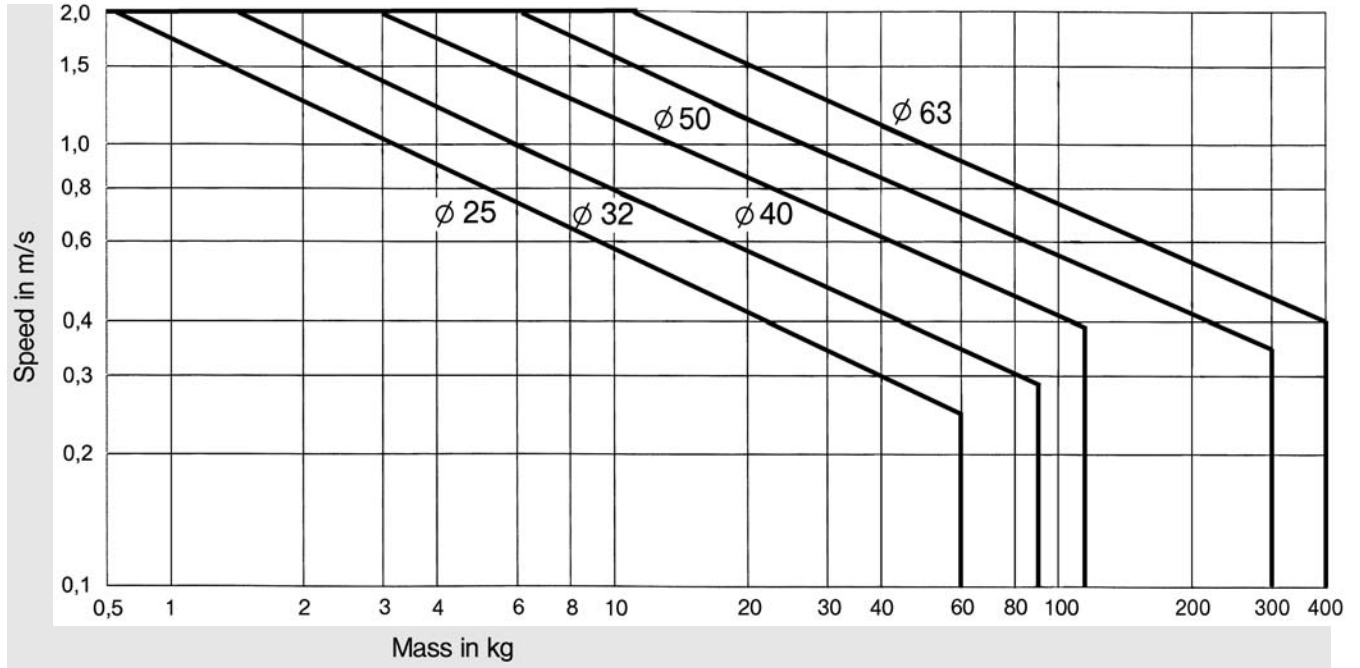

$r_{max.} = 50\text{ mm}$   
for piston- $\phi 25\dots 63\text{ mm}$

For additional loads, please consider the allowed maximum forces and torques on page 10.140.

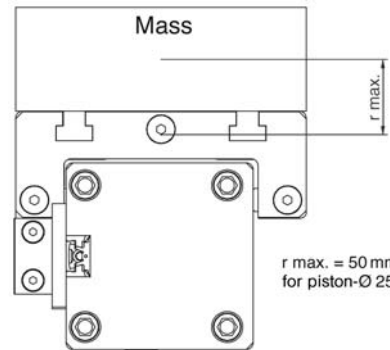

$r_{max.} = 50\text{ mm}$   
for piston- $\phi 25\dots 63\text{ mm}$

**Deflection**

