

Pneumatic cylinders series HE

Single acting, ISO 6432

M5 and G1/8 • piston Ø 8 to 25 mm

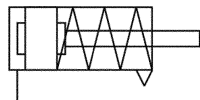

Order code

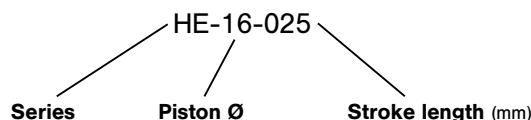

Design and function

Single acting pneumatic cylinder with built-in cushioning rings

Order number Please complete according to order code.	HE-08-...	HE-10-...	HE-12-...	HE-16-...	HE-20-...	HE-25-...
Piston Ø (mm)	8	10	12	16	20	25
Connection	M5 (10/32 UNF)	M5 (10/32 UNF)	M5 (10/32 UNF)	M5	G1/8	G1/8
Piston rod thread	M4	M4	M6	M6	M8	M10 x 1.25
Operating pressure	2 ... 10 bar (29 ... 145 psi)					
Temperature range	- 30 °C ... + 80 °C (- 22 °F ... + 176 °F)					
Medium	Compressed air in accordance with ISO 8573-1:2001, Class 7 4 – and free of aggressive additives					
Standard stroke lengths (mm)¹⁾	10, 25, 50, max. 50					
Materials	Cylinder tube: stainless steel		stainless steel			
	End caps: AI (anodized)		AI (anodized)			
	Piston rod: stainless steel		stainless steel			
	Seals: PU		PU			

¹⁾ = refer to "Critical Load Diagram" on page 9.240 to determine critical values on the piston rod.

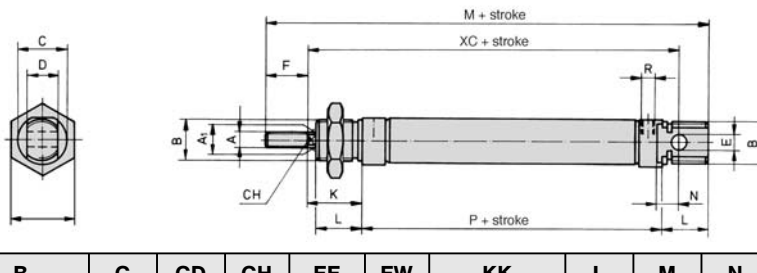

Ø	A ¹	AM	B	C	CD	CH	EE	EW	KK	L	M	N	P	SW	WF	XC
8	4	12	M12 x 1.25	16	4	–	M5	8	M4	6	86	12	46	19	16	64
10	4	12	M12 x 1.25	16	4	–	M5	8	M4	6	86	12	46	19	16	64
12	6	16	M16 x 1.5	19	6	5	M5	12	M6	9	104	18	48	22	22	75
16	6	16	M16 x 1.5	19	6	5	M5	12	M6	9	109	18	53	22	22	82
20	8	20	M22 x 1.5	27	8	7	G1/8	16	M8	12	131	20	67	27	24	95
25	10	22	M22 x 1.5	30	8	9	G1/8	16	M10 x 1.25	12	140	22	68	27	28	104
					H 9			d 13								

Force chart for series HE

Piston Ø		stroke 10		stroke 25		stroke 50	
		min.	max.	min.	max.	min.	max.
Ø 8	Extension	19.0	19.7	19.0	20.3	19.0	21.7
	Retraction	4.5	5.2	3.9	5.2	2.5	5.2
Ø 10	Extension	36.0	36.7	36.0	37.3	36.0	38.7
	Retraction	4.5	5.2	3.9	5.2	2.5	5.2
Ø 12	Extension	51.7	52.0	51.7	52.6	51.7	53.6
	Retraction	5.7	6.0	5.1	6.0	4.1	6.0
Ø 16	Extension	87.5	90.0	87.5	93.5	87.5	99.7
	Retraction	15.0	17.5	11.5	17.5	5.3	17.5
Ø 20	Extension	142.8	145.0	142.8	148.3	142.8	153.8
	Retraction	21.3	23.5	18.0	23.5	12.5	23.5
Ø 25	Extension	243.7	245.0	243.7	247.0	243.7	250.3
	Retraction	18.2	19.5	16.2	19.5	12.9	19.5

Pressure 6 bar. The internal friction is considered.

Pneumatic cylinders series HEZ and HES

Single acting, basis according to ISO 6432

M5 and G1/8 • piston Ø 16 to 25 mm



Force chart for series HEZ, HES

Diameter		stroke 10		stroke 25		stroke 50	
		min.	max.	min.	max.	min.	max.
Ø 16	Extension	87.5	90.0	87.5	93.5	87.5	99.7
	Retraction	15.0	17.5	11.5	17.5	5.3	17.5
Ø 20	Extension	142.8	145.0	142.8	148.3	142.8	153.8
	Retraction	21.3	23.5	18.0	23.5	12.5	23.5
Ø 25	Extension	243.7	245.0	243.7	247.0	243.7	250.3
	Retraction	18.2	19.5	16.2	19.5	12.9	19.5

Pressure 6 bar. The internal friction is considered.

Dimensions for series HEZ

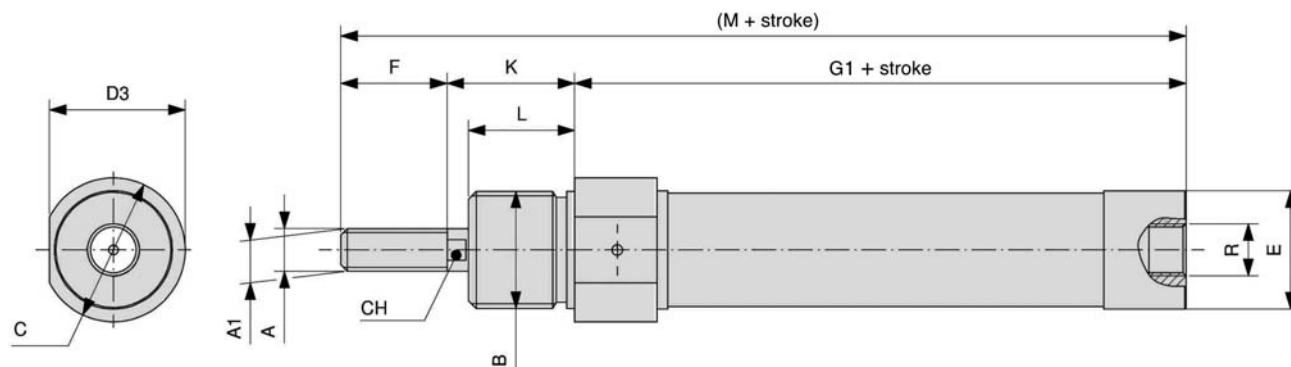

Dimensions for series HES

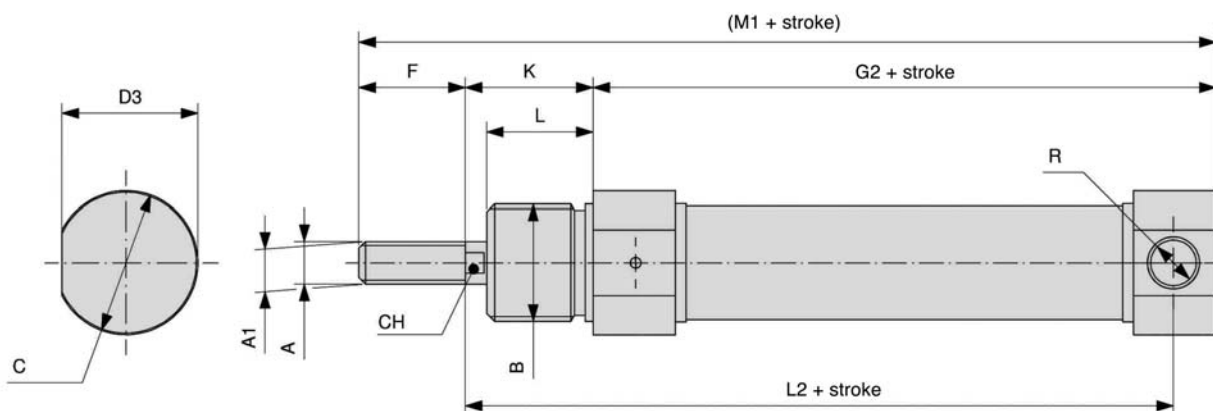

Ø	A	A1	B	C	D3	E	F	G1	G2	K	L	L2	R	M	M1	CH
16	M6	6	M16 x 1.5	19	18	17.2	16	52	52.5	22	18	70	M5	90	90.5	5
20	M8	8	M22 x 1.5	27	25.5	22.2	20	65	67	24	20	83	G1/8	109	111	7
25	M10 x 1.25	10	M22 x 1.5	30	28.5	27	22	66	68	28	22	88	G1/8	116	118	9

Piston rod accessories



Rod eye
RO-
Page 9.212



Flexible coupling
FK-
Page 9.212



Rod clevis with pin
RD-
Page 9.211



Piston rod nut
RL-
Page 9.212

Mounting accessories



Foot mount
Ø 8 – 25
RA-
Page 9.084



Clevis mount
Ø 8 – 25
RC-
Page 9.084

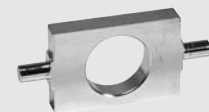

Clevis mount Ø 10 – 25
RH-
Page 9.084



Flange mount
Ø 8 – 25
RB-
Page 9.084



Mounting nut
Ø 8 – 25
RM-

Accessories only for series HM

Proximity sensors for series HM



Sensors
ZS-
Page 9.220



Mounting bracket
NT-250
Page 9.221



Connecting cable
KA-
Page 9.221

Linear guides for series HM

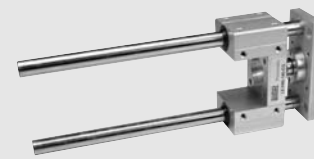

Linear guides
LE-
Page 9.201

Piston Ø	Foot mount	Clevis mount	Threaded bolts	Flange mount	Sensors	Mounting bracket	Rod clevis	Flexible coupling	Rod eye	Mounting nut	Piston rod nut
8	RA-10	RC-10	–	RB-10	ZS-5600	NT-250	RD-10	–	–	RM-10	RL-10
10	RA-10	RC-10	–	RB-10	ZS-5601 ZS-5700		RD-10	–	–	RM-10	RL-10
12	RA-16	RC-16	–	RB-16	ZS-5700-10		RD-16	FK-16	RO-16	RM-16	RL-16
16	RA-16	RC-16	–	RB-16	ZS-5701 ZS-6700	NT-250	RD-16	FK-16	RO-16	RM-16	RL-16
20	RA-25	RC-30	–	RB-25	ZS-6701 ZS-7300	NT-250	RD-20	FK-20	RO-20	RM-25	RL-20
25	RA-25	RC-30	–	RB-25	ZS-7302		RD-25	FK-32	RO-25	RM-25	RL-25

* For piston Ø 8, 10 and 12 mm only electronic switches (ZS-6700, ZS-6701, ZS-7300 or ZS-7302) can be used.

Mounting accessories for series HE and HM

Accessories for pneumatic cylinders
M5 to G1/8 • piston Ø 8 to 25 mm



Foot mount

For Ø 8 – 25

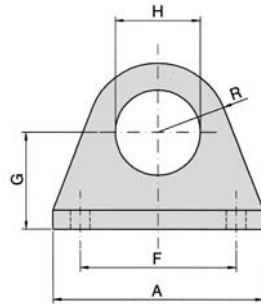

For Ø 8 – 25

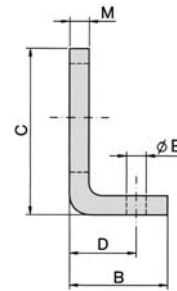

Material: steel (zinc-plated)

Order number	A	B	C	D	E	F	G	H	I	J	K	L	M	R
RA-10	35	16	26	11	4.5	25	16	12	-	-	-	-	3	10
RA-16	42	20	32.5	14	5.5	32	20	16	-	-	-	-	4	12.5
RA-25	54	25	45	17	6.6	40	25	22	-	-	-	-	5	20

Flange mount

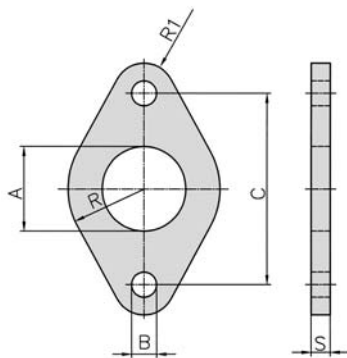

Material: steel (zinc-plated)

Order number	A	B	C	R	R ₁	S
RB-10	12	4.5	30	11	5	3
RB-16	16	5.5	40	15	6	4
RB-25	22	6.6	50	20	8	5

Clevis mount

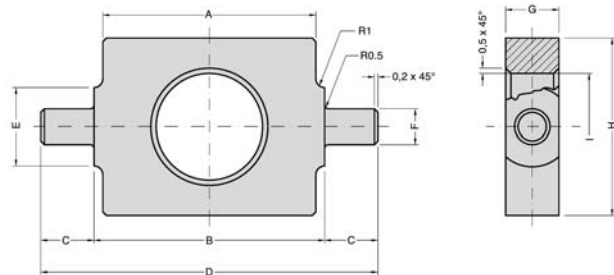

Material: steel (zinc-plated)

Order number	A	B	C	D	E	F	G	H	I
RH-10	24	26	6	38	9	4	6	20	12
RH-16	36	38	10	58	13	6	8	25	16
RH-25	44	46	10	66	13	6	8	30	22
	0						e9		+1.5
	-0.2								+0.5

Clevis mount

For Ø 8 – 25

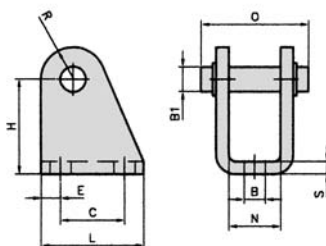

Material: steel (zinc-plated)

Order number	for Cyl.-Ø	B	B ₁	C	H	L	N	O	R	S	E
RC-10	8 + 10	4.5	4	12.5	24	20	8.1	17	5	2.5	5
RC-16	12 + 16	5.5	6	15	27	25	12.1	23	7	3	5
RC-30	20 + 25	6.6	8	20	30	32	16.1	30	10	4	6

Pneumatic cylinders series HMZ and HMS

Double acting, basis according to ISO 6432

M5 and G1/8 • piston Ø 16 to 25 mm

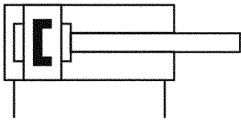

Order code

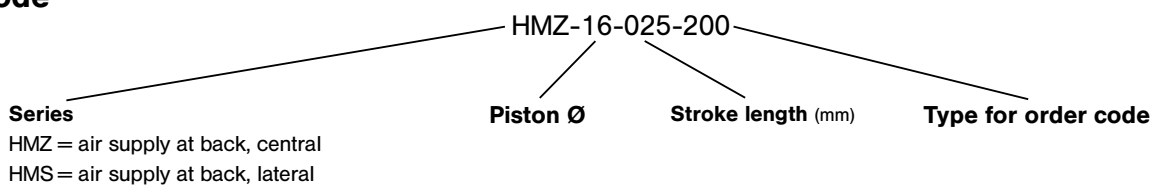

Design and function

Single acting pneumatic cylinder with built-in cushioning rings.

Standard stroke lengths in table below, additional lengths on request

Order number Please complete according to order code.	HMZ-16-...	HMZ-20-...	HMZ-25-...
	HMS-16-...	HMS-20-...	HMS-25-...
Piston Ø (mm)	16	20	25
Connection	M5	G1/8	G1/8
Piston rod thread	M6	M8	M10 x 1.25
Operating pressure	1 ... 10 bar (14.5 ... 145 psi)		
Temperature range	- 30 °C ... + 80 °C (- 22 °F ... + 176 °F)		
Medium	Compressed air in accordance with ISO 8573-1:2001, Class 7 4 -; free of aggressive additives		
Standard stroke lengths (mm) ¹⁾	Ø 16 = 10, 25, 40, 50, 80, 100, 125, 160, 200 Ø 20 = 10, 25, 40, 50, 80, 100, 125, 160, 200, 250, 300, 320 Ø 25 = 10, 25, 40, 50, 80, 100, 125, 160, 200, 250, 300, 320, 400, 500		
Materials	Cylinder tube: stainless steel End caps: Al (anodized) Piston rod: stainless steel Seals: PU		

¹⁾ = refer to "Critical Load Diagram" on page 9.240 to determine critical values on the piston rod.

Pneumatic cylinders series HMZ and HMS

Double acting, Basis according to ISO 6432

M5 and G1/8 • piston Ø 16 to 25 mm



Force chart for series HMZ, HMS

Diameter	Extension	Retraction
Ø 16	109	93
Ø 20	170	142
Ø 25	265	223

Pressure 6 bar. The internal friction is considered.

HMZ

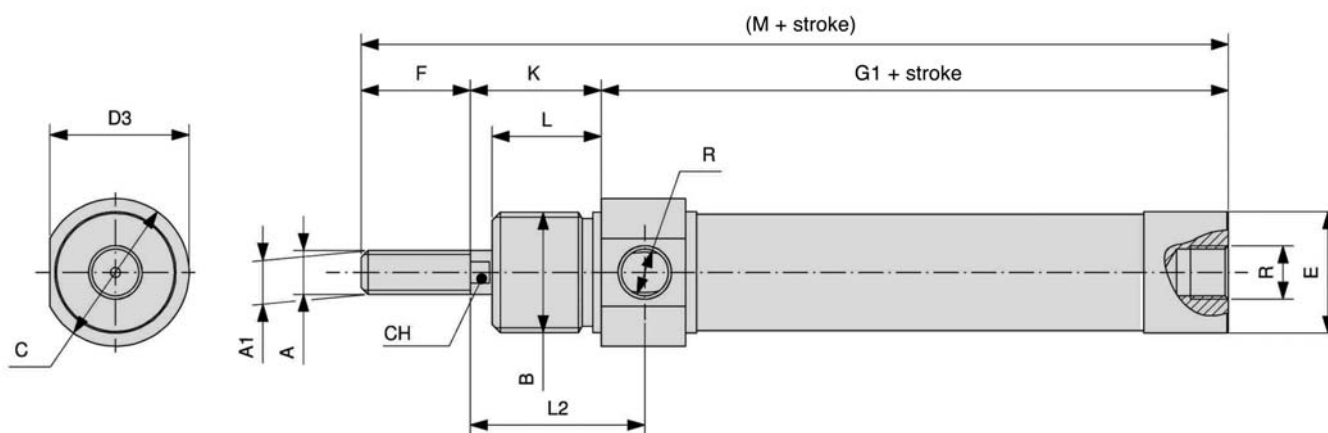

HMS

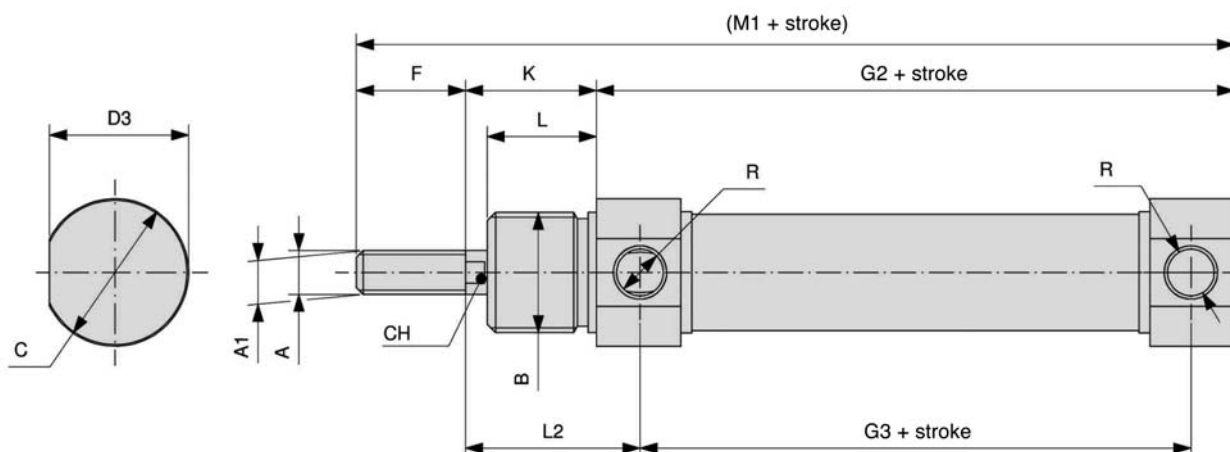

Cyl.-Ø	A	A1	B	C	D3	E	F	G1	G2	G3	K	L	L2	R	M	M1	CH
16	M6	6	M16 x 1.5	19	18	17.2	16	52	52.5	43.5	22	18	26.5	M5	90	90.5	5
20	M8	8	M22 x 1.5	27	25.5	22.2	20	65	67	51	24	20	32	G1/8	109	111	7
25	M10x1.25	10	M22 x 1.5	30	28.5	27	22	66	68	52	28	22	36	G1/8	116	118	9

Assignment to series

Series	Cylinder Ø	Piston rod thread	Rod clevis	Piston rod nut	Flexible coupling	Rod eye
HE and HM	Ø 8 and 10	M4	RD-10	RL-10	-	-
NXD and NXE	Ø 12	M6	RD-16	RL-16	FK-16	RO-16
HE and HM	Ø 12 and 16					
NXD and NXE	Ø 16	M8	RD-20	RL-20	FK-20	RO-20
HE and HM	Ø 20					
NYD and NYE	Ø 20 and 25					
NXD and NXE	Ø 20 to 40	M10 x 1.25	RD-25	RL-25	FK-32	RO-25
HE and HM	Ø 25					
XL	Ø 32					
NYD and NYE	Ø 32 and 40					
NXD and NXE	Ø 50 and 63	M12 x 1.25	FD-40	FE-40	FK-40	FO-40
XL	Ø 40					
NYD and NYE	Ø 50 and 63					
NXD and NXE	Ø 80	M16 x 1.5	FD-63	FE-63	FK-63	FO-63
XL	Ø 50 and 63					
NYD and NYE	Ø 80 and 100					
NXD and NXE	Ø 100	M20 x 1.5	FD-80	FE-80	FK-80	FO-80
XL	Ø 80 and 100					
XL	Ø 125	M27 x 2	FD-125	FE-125	FK-125	FO-125
XG	Ø 160 and 200	M36 x 2	FD-200	FE-200	FK-200	FO-160/200
XG	Ø 250	M42 x 2	FD-250	FE-250	-	-
XG	Ø 320	M48 x 2	FD-320	FE-320	-	-

Rod clevis with pin

Order number	A	B	C	D	E	F	G	H
RD-10	M4	8	16	11.5	4	21	8	4
RD-16	M6	12	24	16	6	31	12	6
RD-20	M8	16	32	22	8	42	16	8
RD-25	M10 x 1.25	20	40	26	10	52	20	10
RD-32	M10	20	40	26	10	52	20	10
RD-40	M12	24	48	32	12	62	24	12
RD-63	M16	32	64	36	16	83	32	16
FD-40	M12 x 1.25	24	48	32	12	62	24	12
FD-63	M16 x 1.5	32	64	40	16	83	32	16
FD-80	M20 x 1.5	40	80	50	20	105	40	20
FD-125	M27 x 2	54	110	65	30	148	55	30
FD-200	M36 x 2	72	144	84	35	188	70	35
FD-250	M42 x 2	84	168	104.5	40	232	85	40
FD-320	M48 x 2	96	192	117.5	50	265	96	50

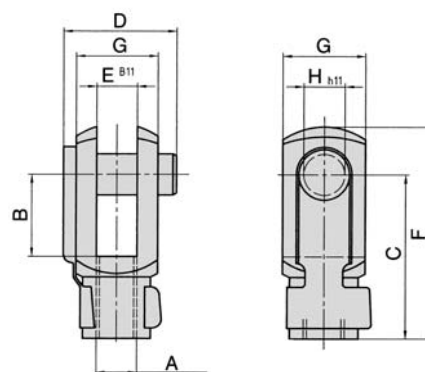

Material: steel (zinc-plated)
spring steel

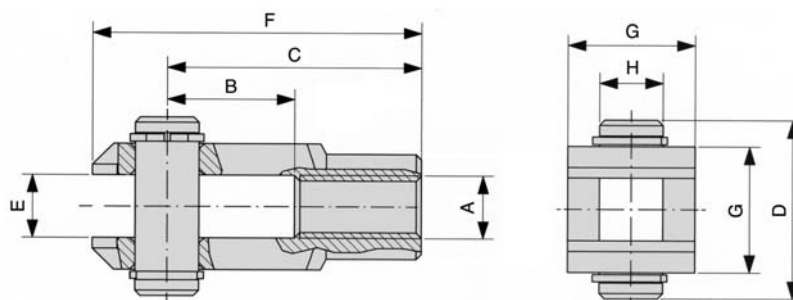

Rod clevis FD-125 to FD-320, pin with snap rings.

Piston rod accessories

Piston rod nut

Order number	A	B	C
RL-10	M4	3.2	7
RL-16	M6	4	10
RL-20	M8	5	13
RL-25	M10 x 1.25	5	17
RL-32	M10	5	17
RL-40	M12	6	19
RL-50/63	M16	8	24
FE-40	M12 x 1.25	6	19
FE-63	M16 x 1.5	8	24
FE-80	M20 x 1.5	10	30
FE-125	M27 x 2	13.5	41
FE-200	M36 x 2	18	55
FE-250	M42 x 2	21	65
FE-320	M48 x 2	24	75

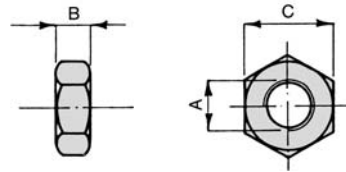

Material: steel (zinc-plated)

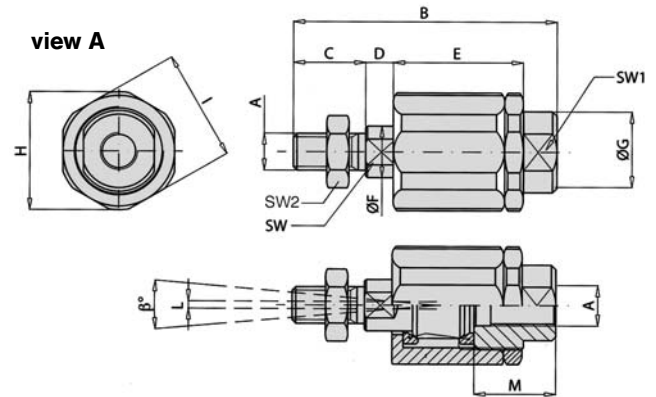

Flexible coupling



Material: steel (zinc-plated)

Order number	A	B	C	D	E	Ø F	Ø G	Ø H	I	L	M	SW	SW1	SW2	β°
FK-16	M6	35	11	2.5	17.5	6	8.5	14.5	13	1	12.5	5	7	10	6°
FK-20	M8	57	21	5	26	8	12.5	19	17	2	16	7	11	13	8°
FK-32	M10 x 1.25	71.5	20	7.5	35	14	22	32	30	2	22	12	19	17	8°
FK-33	M10	71.5	20	7.5	35	14	22	32	30	2	22	12	19	17	8°
FK-40	M12 x 1.25	75.5	24	7.5	35	14	22	32	30	2	22	12	19	19	8°
FK-41	M12	75.5	24	7.5	35	14	22	32	30	2	22	12	20	19	9°
FK-63	M16 x 1.5	104	32	10	53	22	32	45	41	2	30	20	27	24	6°
FK-80	M20 x 1.5	119	40	10	53	22	32	45	41	2	37	20	27	30	6°
FK-125	M27 x 2	147	54	10	60	32	57	70	65	2	48	24	54	41	8°
FK-200	M36 x 2	190	72	15.5	77	39	57	75	70	2	68	32	54	55	8°

Rod eye



Material: steel (zinc-plated)
stainless steel

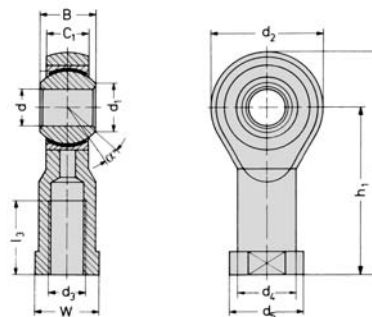

Order number	d ₃	d	d ₁	d ₂	d ₄	d ₅	B	C ₁	W	L ₃	L ₄	h ₁	α
RO-16	M6	6	8.9	20	10	13	9	6.75	11	12	40	30	13
RO-20	M8	8	10.4	24	12.5	16	12	9	14	16	48	36	14
RO-25	M10 x 1.25	10	12.9	28	15	19	14	10.5	17	20	57	43	13
RO-32	M10	10	12.9	28	15	19	14	10.5	17	20	57	43	13
RO-40	M12	12	15.4	32	17.5	22	16	12	19	22	66	50	13
RO-50	M16	16	19.3	42	22	27	21	15	22	28	85	64	15
FO-40	M12 x 1.25	12	15.4	32	17.5	22	16	12	19	22	66	50	13
FO-63	M16 x 1.5	16	19.3	42	22	27	21	15	22	28	85	64	15
FO-80	M20 x 1.5	20	24.3	50	27.5	34	25	18	30	33	102	77	14
FO-125	M27 x 2	30	34.8	70	40	50	37	25	41	51	145	110	17
FO-160/200	M36 x 2	35	37.7	80	46	58	43	28	50	56	165	125	16
FO-250	M42 x 2	40	45.1	91	53	65	49	33	55	60	187	142	16
FO-320	M48 x 2	50	56.6	117	65	75	60	45	65	65	218	162	14

Piston rod accessories stainless steel

Assignment to series

Series	Piston rod thread	Rod clevis	Piston rod nut	Rod eye
CM-16	M6	PD-16	PL-16	PO-16
CM-20	M8	PD-20	PL-20	PO-20
CM-25	M10 x 1.25	PD-25	PL-25	PO-25
CX-32				
CX-40	M12 x 1.25	PD-40	PL-40	PO-40
CX-50	M16 x 1.5	PD-63	PL-63	PO-63
CX-63				
CX-80	M20 x 1.5	PD-80	PL-80	PO-80
CX-100				

Rod clevis with pin

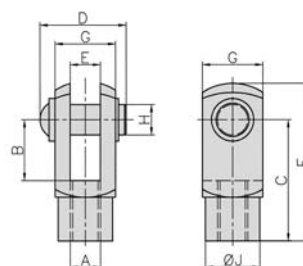

Material: stainless steel 1.4305

Order number	A	B	C	D	E	F	G	H	J
PD-16	M6	12	24	17	6	31	12	6	10
PD-20	M8	16	32	20	8	42	16	8	14
PD-25	M10 x 1.25	20	40	25	10	52	20	10	18
PD-40	M12 x 1.25	24	48	30	12	62	24	12	20
PD-63	M16 x 1.5	32	64	39	16	83	32	16	26
PD-80	M20 x 1.5	40	80	48	20	105	40	20	34
			± 0,3					h ₁₁	

Rod eye

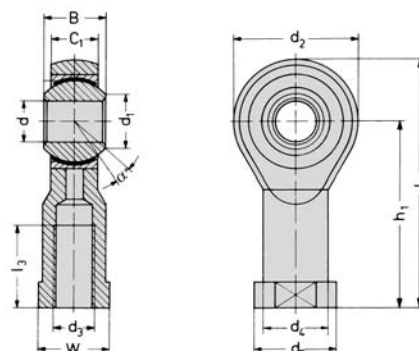

Material Body: stainless steel 1.4057
 Bearing housing: stainless steel 1.4571 PTFE coated
 Inner ring: stainless steel 1.4034 hardened

Order number	d ₃	d	d ₁	d ₂	d ₄	d ₅	B	C ₁	W	L ₃	L ₄	h ₁	α
PO-16	M6	6	8.9	20	10	13	9	6.75	11	12	40	30	13
PO-20	M8	8	10.4	24	12.5	16	12	9	13	16	48	36	13
PO-25	M10 x 1.25	10	12.9	28	15	19	14	10.5	17	20	57	43	13
PO-40	M12 x 1.25	12	15.4	32	17.5	22	16	12	19	22	66	50	13
PO-63	M16 x 1.5	16	19.3	42	22	27	21	15	22	28	85	64	15
PO-80	M20 x 1.5	20	24.3	50	27.5	34	25	18	32	33	102	77	15

Piston rod nut

Order number	A	B	C
PL-16	M6	3.2	10
PL-20	M8	4	13
PL-25	M10 x 1.25	5	17
PL-40	M12 x 1.25	6	19
PL-63	M16 x 1.5	8	24
PL-80	M20 x 1.5	10	30

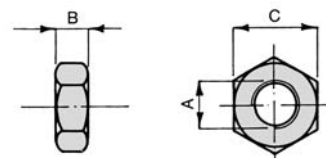

Material: stainless steel 1.4301

Proximity sensors

Wiring diagram

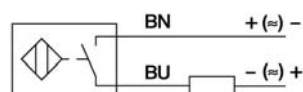

Reed
ZS-5600

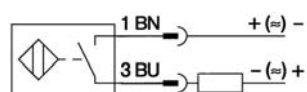

Reed
ZS-5601

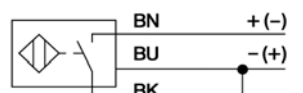

Reed
ZS-5700, ZS-5700-10

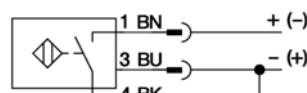

Reed
ZS-5701

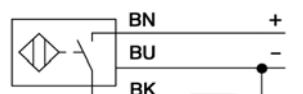

PNP
ZS-6700, ZS-7300

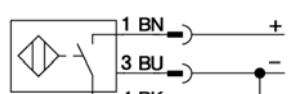

PNP
ZS-6701, ZS-7302 (dimensions for ZS-7302, page 9.221)

Dimensions

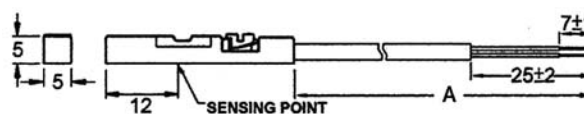

ZS-5600, ZS-6700, ZS-7300; A = 3.000 ± 20

ZS-5700; A = 5.000 ± 20

ZS-5700-10; A = 10.000 ± 20

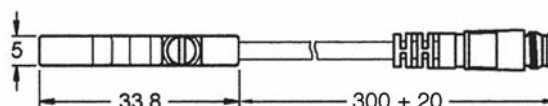

ZS-5601, ZS-5701, ZS-6701

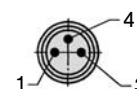

Function principles

Magnetic field sensors are actuated by magnetic fields and are especially suited for piston position detection in pneumatic cylinders. Based on the fact that magnetic fields can permeate non-magnetizable metals, it is possible to detect a permanent magnet attached to the piston through the aluminum wall of the cylinder.

Mounting tip

The sensor is firmly fixed in the groove by clockwise rotation of the screw.

Proximity sensors Reed contact



Order number	ZS-5600	ZS-5601	ZS-5700	ZS-5700-10	ZS-5701
Design	2-pole Reed sensor (non-polarized) normally open		3-pole Reed sensor* normally open		
Cable	ø 2.8, PUR				
Cable cross section	n/a				
Cable length	3 m	0.3 m	5 m	10 m	0.3 m
Cable plug	-	M8	-	-	M8
Overtravel speed	n/a				
Max. absolute hysteresis	n/a				
Temperature drift	n/a				
min. absolute repeat accuracy	n/a				
Operating temperature	- 10 °C ... + 70 °C				
Degree of protection	IP 67				
Housing material	Plastic				
Switching status indication	LED red		LED yellow		
Rated operational voltage	5 ... 240 V AC/DC	5 ... 60 V AC/DC	5 ... 30 V DC		
Rated operational current I_E	3 ... 100 mA		≤ 500 mA		
DC	3 ... 100 mA		≤ 500 mA		
AC	3 ... 100 mA		≤ 500 mA		
Breaking capacity	≤ 10 W				
No-load current	n/a		≤ 10 mA		
Max. OFF-state current	0 mA				
Max. switching frequency	≤ 0.2 kHz				
Rated insulation voltage	n/a				
Short-circuit protection	no				
Max. voltage drop at I_E	≤ 2.5 V		≤ 0.1 V		
Wire breakage	no				
Reverse polarity protection	yes				
Vibration resistance	9 g (1.5 mm, 10 – 55 Hz – 10 Hz)				
Shock resistance	30 g (11 ms)				
Explosion proof	-				

* Useable as 2-wire contact, voltage 0 ... 30 V AC / 0 ... 30 V DC, LED has no function.

Proximity sensors

Mounting bracket for round cylinder Ø 8 – 63 mm



Material: metal,
plastic PA GI/6T

Order number	Piston Ø
NT-250	8 to 25 mm
NT-500	32 to 63 mm

Dimensions for ZS-7302

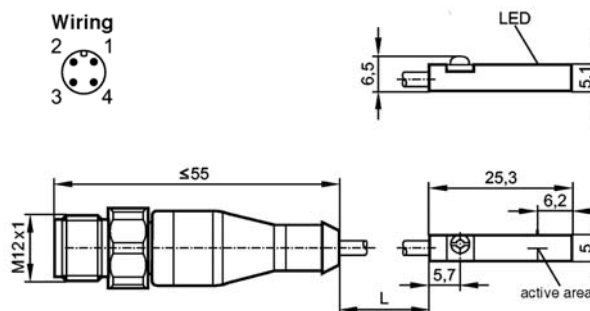

Connecting cable for ZS-5601, ZS-5701 and ZS-6701

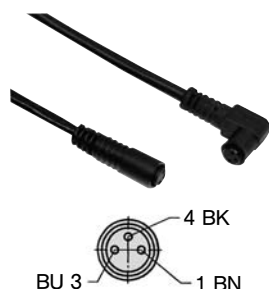

Cable: PUR, black, 3 x 0.25 mm², Ø 3.9, high flexible
Operating voltage 0 ... 48 V AC/DC

Order number	Length of cable	Connection
KA-30	3 m	8 mm sensor snap-in, straight
KA-50	5 m	8 mm sensor snap-in, straight
KA-51	5 m	8 mm sensor snap-in, 90°
KA-100	10 m	8 mm sensor snap-in, straight
KA-101	10 m	8 mm sensor snap-in, 90°

Proximity sensors electronic

Order number	ZS-6700	ZS-6701	ZS-7300	ZS-7302
Design	electronic, magnet-induktive sensor, normally open PNP output			
Cable	Ø 2,8, PUR		n/a	
Cable cross section	n/a		3 x 0,14 mm ²	
Cable lengths	3 m	0,3 m	6 m	0,3 m
Cable plug	-	M8	-	M12
Overtravel speed	n/a		≤ 10 m/s	
Max. absolute hysteresis	n/a		n/a	
Temperatur drift	n/a		≤ 0,1 mm	
Min. absolute repeat accuracy	n/a		≤ 0,2 mm	
Operating temperature	- 10 °C ... + 70 °C		- 25 °C ... + 60 °C	
Degree of protection	IP 67		IP65/IP67	IP 67
Housing material	Plastic		Body: PA; Mounting band: stainless steel	
Switching status indication	LED green		LED yellow	
Rated operational voltage	5 ... 30 V DC		10 ... 30 V DC	
Rated operational current I_E	≤ 200 mA		≤ 100 mA	
DC	-		-	
AC	-		-	
Breaking capacity	6 W		n/a	
No-load current	≤ 10 mA		≤ 10 mA	
Max. OFF-state current	n/a		n/a	
Max. switching frequency	≤ 1 kHz		> 6.000 Hz	> 10.000 Hz
Rated insulation voltage	n/a		n/a	
Short-circuit protection	yes		yes	
Max. voltage drop at I_E	≤ 1,0 V		≤ 2,5 V	
Wire breakage	yes		n/a	
Reverse polarity protection	yes		yes	
Vibration resistance	9 g (1.5 mm, 10 – 55 Hz – 10 Hz)		n/a	
Shock resistance	50 g (11 ms)		n/a	
Explosion proof	-		EX II 3G Ex nA T4 X EX II 3D Ex tD A22 IP67 T125°C X	EX II 3D Ex tc IIIC T125°C Dc X

Force chart

The chart shows extension and retraction forces for double acting cylinders in N. A correction factor of 0,9 for the internal friction is already calculated. Minor influences based on the cushioning bushings are disregarded.

Cylinder Ø	Cylinder series	Rod diameter Ø	Piston area [cm ²]	Pressure in bar							
				2	3	4	5	6	7	8	
8	HM	4	Extension force 0,50	9	14	18	23	27	32	36	
			Retraction force 0,38	7	10	14	17	20	24	27	
10	HM	4	Extension force 0,79	14	21	28	35	42	49	57	
			Retraction force 0,66	12	18	24	30	36	42	47	
12	HM	6	Extension force 1,13	20	31	41	51	61	71	81	
			Retraction force 0,85	15	23	31	38	46	53	61	
16	HM, CM	6	Extension force 2,01	36	54	72	90	109	127	145	
			Retraction force 1,73	31	47	62	78	93	109	124	
	NXD	8	Retraction force 1,51	27	41	54	68	81	95	109	
20	HM, CM	8	Extension force 3,14	57	85	113	141	170	198	226	
			Retraction force 2,64	47	71	95	119	142	166	190	
	NXD, NYD, LX	10	Retraction force 2,36	42	64	85	106	127	148	170	
25	HM, NXD, NYD, CM	10	Extension force 4,91	88	132	177	221	265	309	353	
			Retraction force 4,12	74	111	148	185	223	260	297	
	LX	12	Retraction force 3,78	68	102	136	170	204	238	272	
32	XL, NXD, NYD, CX	12	Extension force 8,04	145	217	289	362	434	506	579	
			Retraction force 6,91	124	187	249	311	373	435	497	
	LX	16	Retraction force 6,03	109	163	217	271	326	380	434	
40	NXD, NYD	12	Extension force 12,56	226	339	452	565	678	791	904	
			Retraction force 11,43	206	309	411	514	617	720	823	
	XL, LX, CX	16	Retraction force 10,55	190	285	380	475	570	665	760	
50	NXD, NYD	16	Extension force 19,63	353	530	707	883	1060	1236	1413	
			Retraction force 17,62	317	476	634	793	951	1110	1268	
	XL, LX, CX	20	Retraction force 16,49	297	445	593	742	890	1039	1187	
63	NXD, NYD	16	Extension force 31,16	561	841	1122	1402	1682	1963	2243	
			Retraction force 29,15	525	787	1049	1312	1574	1836	2099	
	XL, LX, CX	20	Retraction force 28,02	504	756	1009	1261	1513	1765	2017	
80	NXD, NYD	20	Extension force 50,24	904	1356	1809	2261	2713	3165	3617	
			Retraction force 47,10	848	1272	1696	2120	2543	2967	3391	
	XL, CX	25	Retraction force 45,33	816	1224	1632	2040	2448	2856	3264	
100	XL, NXD,	25	Extension force 78,50	1413	2120	2826	3533	4239	4946	5652	
	NYD, CX		Retraction force 73,59	1325	1987	2649	3312	3974	4636	5299	
125	XL	32	Extension force 122,66	2208	3312	4416	5520	6623	7727	8831	
			Retraction force 114,62	2063	3095	4126	5158	6189	7221	8252	
160	XG	40	Extension force 200,96	3617	5426	7235	9043	10852	12660	14469	
			Retraction force 188,40	3391	5087	6782	8478	10174	11869	13565	
200	XG	40	Extension force 314,00	5652	8478	11304	14130	16956	19782	22608	
			Retraction force 301,44	5426	8139	10852	13565	16278	18991	21704	
250	XG	50	Extension force 490,63	8831	13247	17663	22078	26494	30909	35325	
			Retraction force 471,00	8478	12717	16956	21195	25434	29673	33912	
320	XG	63	Extension force 803,84	14469	21704	28938	36173	43407	50642	57876	
			Retraction force 772,68	13908	20862	27817	34771	41725	48679	55633	

Technical charts

This table shows the air consumption for a single stroke of 100 mm. These statements are based upon extension and are in NI.

Piston Ø mm	Air pressure in bar/psi						
	2 (29 psi)	3 (43.4 psi)	4 (58 psi)	5 (72.5 psi)	6 (87 psi)	7 (101.5 psi)	8 (116 psi)
8	0.02	0.02	0.03	0.03	0.04	0.04	0.05
10	0.02	0.03	0.04	0.05	0.05	0.06	0.07
12	0.03	0.05	0.06	0.07	0.08	0.09	0.10
16	0.06	0.08	0.10	0.12	0.14	0.16	0.18
20	0.09	0.13	0.16	0.19	0.22	0.25	0.28
25	0.15	0.20	0.25	0.29	0.34	0.39	0.44
32	0.24	0.32	0.40	0.48	0.56	0.64	0.72
40	0.38	0.50	0.63	0.75	0.88	1.01	1.13
50	0.59	0.79	0.98	1.18	1.37	1.57	1.77
63	0.94	1.25	1.56	1.87	2.18	2.49	2.81
80	1.51	2.01	2.51	3.02	3.52	4.02	4.52
100	2.36	3.14	3.93	4.71	5.50	6.28	7.07

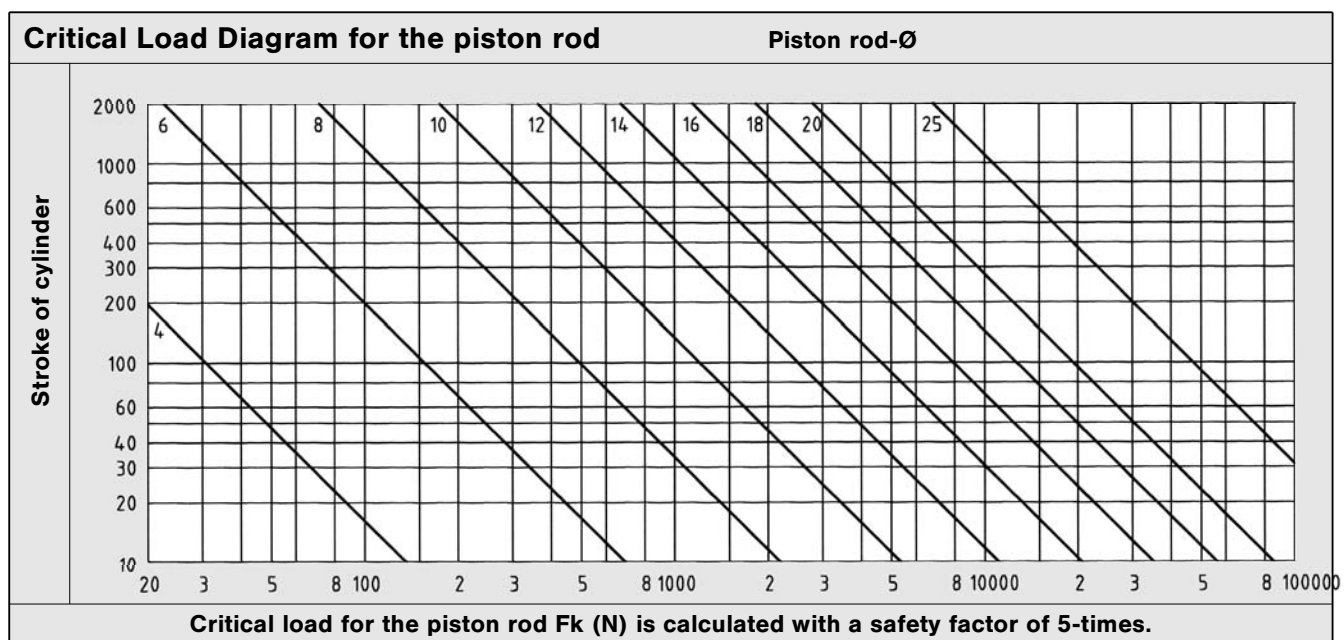

$$F_k = \frac{\pi^2 E I}{L_k^2 S}$$

- F_k = permitted critical force (N)
- E = elasticity module (N/mm²)
- I = moment of inertia (mm⁴)
- L_k = effective length of critical load
- S = security

Elastic cases of buckling according to Euler

