

Maxifluss Rotary Plug Valve VETEC Type 73.3

Double eccentric control valve for process engineering and industrial applications

Valve size	DN 25 to DN 250	
Nominal pressure	PN 63 to PN 160	
Temperature	–100 to 400 °C	–148 to 752 °F

Valve body made of

- Cast/carbon steel or
- Stainless cast/carbon steel

Seat version

- Metal sealing, armored or unarmored

The valves can be equipped with different accessories, such as positioners, solenoid valves and other accessories according to VDI/VDE 3845.

Standard version

For temperatures from –100 to 400 °C (–148 to 752 °F)

Version

Flanged version

- DN 25 to DN 250, PN 63 to PN 160, face-to-face dimensions acc. to EN 558-1, Table 10, Series 2

Further versions

- TA-Luft packing/double packing
- Heating jacket
- Special materials for body and trim
- Noise-reducing features
- Flange version with tongue/groove, male face/female face according to EN 1092-1
- RF and RTJ according to ANSI
- Versions for higher and lower temperatures on request



Fig. 1: VETEC Type 73.3 Maxifluss Rotary Plug Valve (example with mounted Type R Actuator)

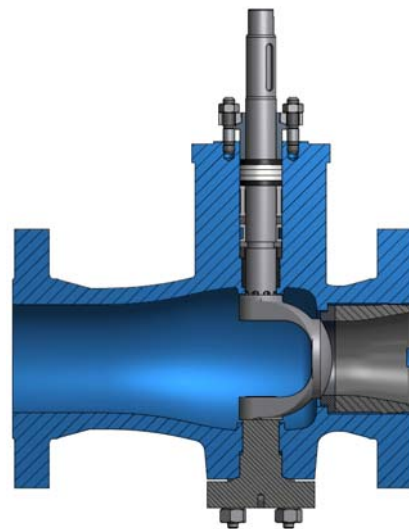

Fig. 2: Sectional drawing

Principle of operation

The shaft/plug arrangement is eccentric (Figs. 3 and 4). The double-eccentric design of the Maxifluss rotary plug valve is achieved in combination with the offset of the plug's pivot. When turning the plug shaft from closed position in opening direction, the double-eccentric design allows the plug to lift off the seat smoothly without initial breakaway torque. The valve is not opened suddenly and shows a stable control response even with small opening angles. The rotary plug valve can be used for both directions of flow.

For gases and vapors, the direction of flow is FTC (medium closes).

The flow coefficient depends on the opening angle of the valve.

Using positioners or cam disks, the natural characteristic of the Maxifluss rotary plug valve can be modified to achieve a linear or equal-percentage characteristic (Figs. 5 and 6).

Fail-safe action

In combination with the Type R/M/other Rotary Actuators, the control valve has two fail-safe actions, which become effective when the piston is relieved of pressure or when the supply air fails.

Valve CLOSED without supply air: Maxifluss rotary plug valve is closed when the supply air fails.

Valve OPEN without supply air: Maxifluss rotary plug valve is opened when the supply air fails.

Installation

Observe the direction of flow indicated by the arrow on the valve body.

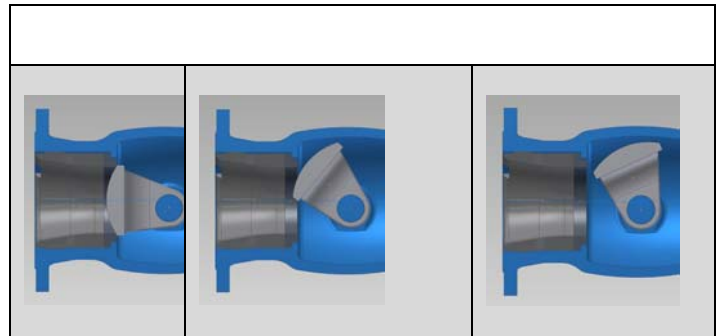

Fig. 3: Double-eccentric principle

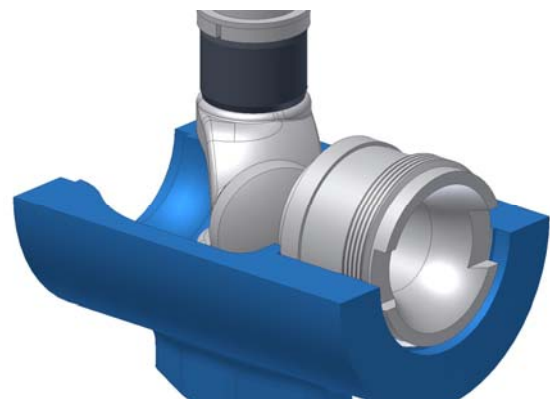

Fig. 4: Plug movement with double-eccentric arrangement

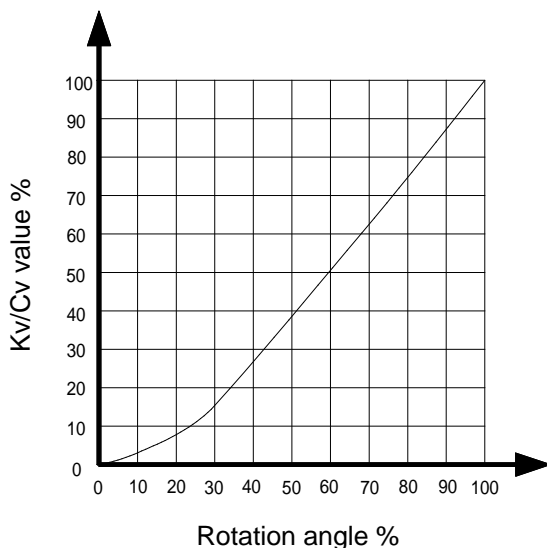

Fig. 5: Natural characteristic

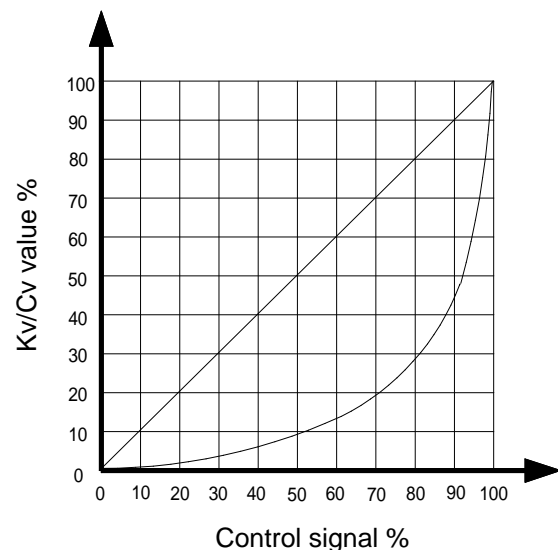

Fig. 6: Equal-percentage and linear characteristic

Table 1: Technical data

Maxifluss Type	73.3	
Valve size	DN 25 to DN 250	
Style	Flange	
Flange pressure rating	PN 63/100/160	
Max. operating pressure	160 bar	
Overall length	EN 558-1, Table 10, Series 2	
Flange bore/form	DIN EN 1591-1/DIN 2500	
Seat ring	 <p>Direction of flow from the front: FTO</p>	 <p>Direction of flow from behind: FTC</p>
Characteristic	Equal percentage or linear (using cam disk or positioner characteristic) On/off valve	
Rangeability	200:1	
Temperature range	Medium: -100 to +400 °C	
Opening angle	75°	

Table 2: Materials

Body	1.0619/A216 WCC	1.4408/A351 CF8M
Shaft	1.4404	
Plug	1.4404/Stellite 6	
Trunnion bearing	1.4404	
Seat ring	1.4404 armored with carbide metal/seat with soft sealing	
Seat holder	1.4404	
O-ring on seat	FPM 80 VR1	
Bearing bushing	1.4404/plastic	
Packing	1.4404	
O-ring	FPM 80 VR1	
Screw plug	1.4404	
Screw plug seal	1.4404	
Trunnion bearing seal	Graphite/stainless steel/PTFE	
Packing	PTFE/graphite	

Table 3: Kvs and Cv coefficients

3a. seat with metal sealing FTO

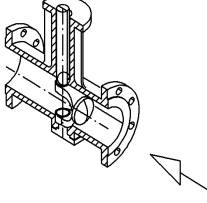
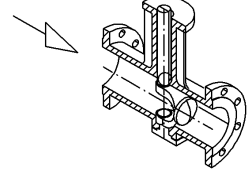
DN		25	40	50	80	100	150	200	250
NPS		1	1 1/2	2	3	4	6	8	10
Flow rate									
100%	Kvs	16	36	70	220	360	720	1100	1950
	Cv	18	42	81	254	416	832	1272	2254
	Seat Ø (mm)	18	26	36	60	76	105	135	170
60%	Kvs	12	22	43	145	210	430	630	1230
	Cv	14	25	50	168	243	497	728	1422
	Seat Ø (mm)	16	21,5	29,5	50	60	86	106	146
40%	Kvs	10	16	31	105	150	275	390	850
	Cv	12	18	36	121	173	318	451	983
	Seat Ø (mm)	14	18,5	25,5	44	53	73	88	126
25%	Kvs	4	12	19	70	100	185	245	500
	Cv	4,6	14	22	81	116	214	283	578
	Seat Ø (mm)	10	16	21	37	45	62	73	102

3b. seat with metal sealing FTC

DN		25	40	50	80	100	150	200	250
NPS		1	1 1/2	2	3	4	6	8	10
Flow rate									
100%	Kvs	16	36	70	210	340	660	810	1300
	Cv	18	42	81	243	393	763	936	1503
	Seat Ø (mm)	18	26	36	60	76	105	135	170
60%	Kvs	12	22	43	135	200	320	410	820
	Cv	14	25	50	156	231	370	474	948
	Seat Ø (mm)	16	21,5	29,5	50	60	86	106	146
40%	Kvs	10	16	31	95	120	185	250	540
	Cv	12	18	36	110	139	214	289	624
	Seat Ø (mm)	14	18,5	25,5	44	53	73	88	126
25%	Kvs	4	12	19	56	90	125	160	320
	Cv	4,6	14	22	65	104	145	185	370
	Seat Ø (mm)	10	16	21	37	45	62	73	102

3c. seat with soft sealing FTC

DN	25	40	50	80	100	150	200	250
NPS	1	1 1/2	2	3	4	6	8	10

Flow rate

100%	Kvs	12	40	68	180	290	535	730	1220
	Cv	14	42	79	208	335	618	844	140
	Seat Ø (mm)	16	26	35	54	70	98	128	160
60%	Kvs	11	22	43	135	200	320	410	820
	Cv	13	25	50	156	231	370	474	948
	Seat Ø (mm)	15	21,5	29,5	50	60	86	106	146
40%	Kvs	10	16	31	105	120	185	250	540
	Cv	12	18	36	121	139	214	289	624
	Seat Ø (mm)	14	18,5	25,5	46	53	73	88	126
25%	Kvs	4	12	19	56	90	125	160	320
	Cv	4,6	14	22	65	104	145	185	370
	Seat Ø (mm)	10	16	21	37	45	62	73	102

Table 4: Weight in kg (without actuator)

DN	25	40	50	80	100	150	200	250
Weight (kg)	16	27	34	56	77	173	261	369

Table 5: DIN face-to-face dimensions

	DN	25	40	50	80	100	150	200	250
PN 63	Length (mm)	230	260	300	380	430	550	650	775
PN 100									
PN 160									

Table 6: ANSI face-to-face dimensions

	NPS	1	1½	2	3	4	6	8	10
Class 600	Length (mm)	210	251	286	337	394	508	610	752
Class 900		254	305	368		457			

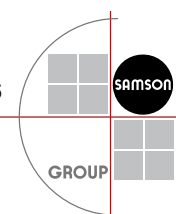

Order specifications:

Type	According to table
Valve size	DN ...
Nominal pressure	PN ...
Body material	According to table
Seat version	Metal seal
Characteristic	Equal percentage or linear
Kvs/Cv	According to table
Direction of flow	Standard: FTO (medium opens) Reverse: FTC (medium closes)
Actuator	Type
Type of mounting	Mounting location of actuator
Fail-safe action	when supply air fails Fail-close Fail-open
Max. differential pressure for	... bar
Supply air	... bar
Bench range	... bar
Accessories	e.g. positioners, limit switches, solenoid valve etc.
Others	e.g. special version, certificates, approvals etc.