

## VETEC Maxifluss Rotary Plug Valve Type 62.7

Double eccentric control valve for process engineering and industrial applications

Valve size	DN 25 to 200	NPS 1 to 8
Nominal Pressure	PN 10 to 40	Class 150 and 300
Temperature	-60 °C to 220°C	-76 °F to 428 °F

### Valve body made of

- Cast/carbon steel
- Stainless cast/carbon steel
- Low temperature cast/carbon steel

### Seat version

- Metal sealing
- Soft sealing

### Flanged version

- DN 25 to DN 200 PN10/16/25/40, face to face dimensions acc. to EN 558 table 16, series 36
- NPS 1 to 8, Class 150/300, face to face dimensions acc. to EN 558 table 16, series 36

### Standard version

For ambient air temperatures from -29°C to + 80 °C  
(-20°F to 176°F)

### Version for cryogenic temperature

For ambient air temperatures from -55°C to + 80 °C  
(-67°F to 176°F)

The valves can be equipped with different accessories, such interface according to VDI/VDE 3845.

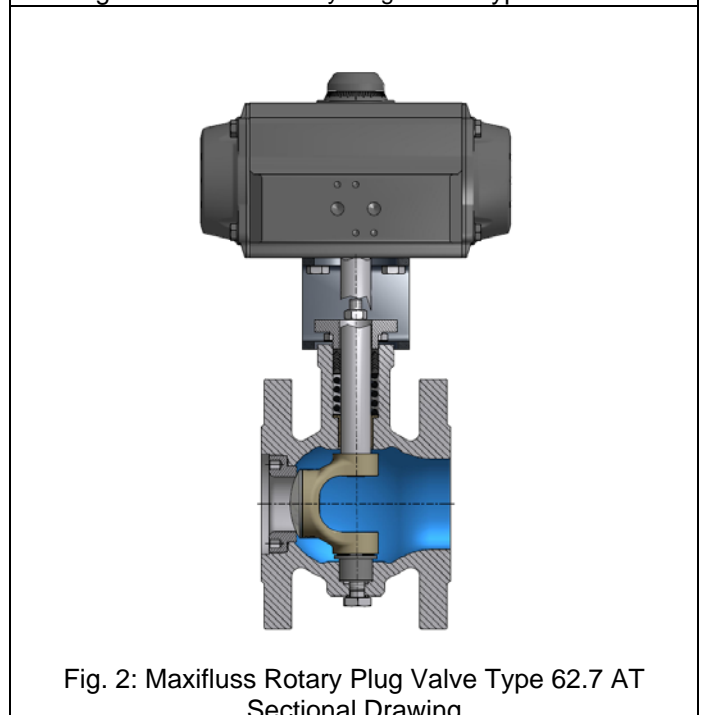

**Principle of operation**

The shaft/plug arrangement is eccentric (Figs.3 and 4). The double-eccentric design of the Maxifluss rotary plug valve is achieved in combination with the offset of the plug's pivot. The double-eccentric design allows the plug to lift off the seat immediately.

Direction of flow = FTC (medium closes) (Fig.5)

The flow coefficient depends on the opening angle of the valve.

Using positioners, the natural characteristic of the Maxifluss rotary plug valve can be modified to achieve a linear or equal-percentage characteristic (Figs.6 and 7).

**Fail-safe action**

In combination with the Type AT Actuators, the control valve has two fail-safe actions, which become effective when the piston is relieved of pressure or when the supply air fails.

**Control Valve CLOSED without supply air:** Maxifluss rotary plug valve closes when the supply air fails.

**Control Valve OPEN without supply air:** Maxifluss rotary plug valve opens if the supply air fails.

**Installation**

Observe the direction of flow indicated by the arrow on the valve body.

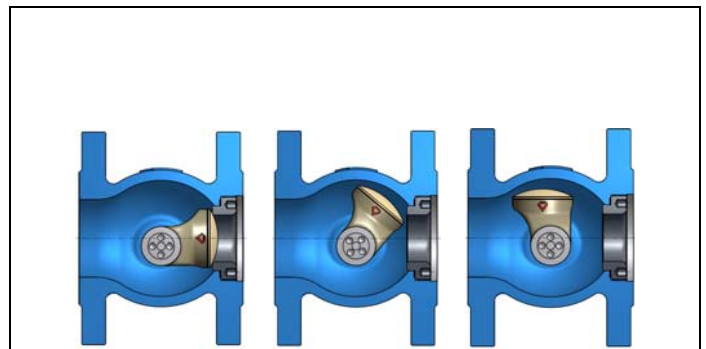

Fig.3 Double-eccentric principle

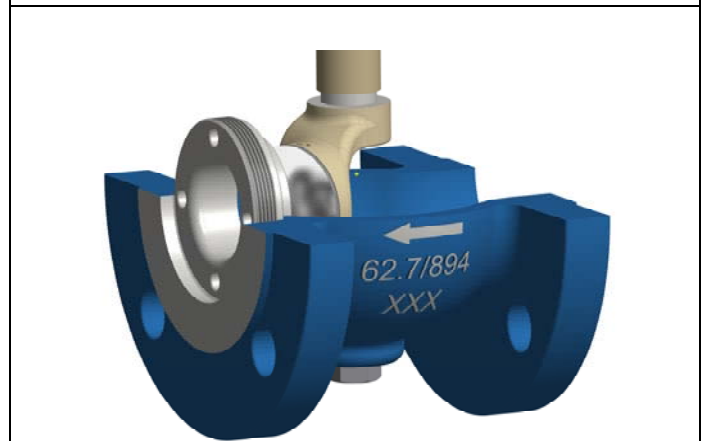

Fig.4 Plug movement with double-eccentric arrangement



Flow Direction

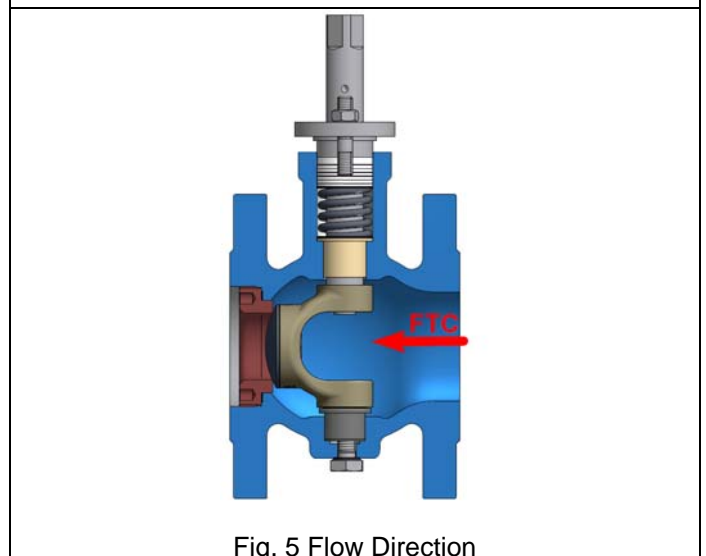

Fig. 5 Flow Direction

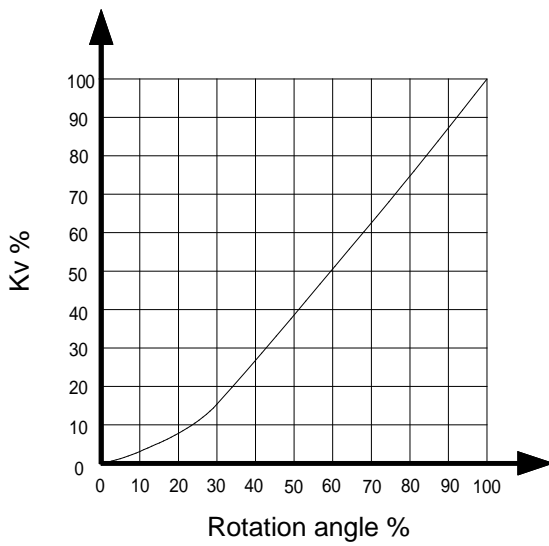

Fig. 6: Natural characteristic

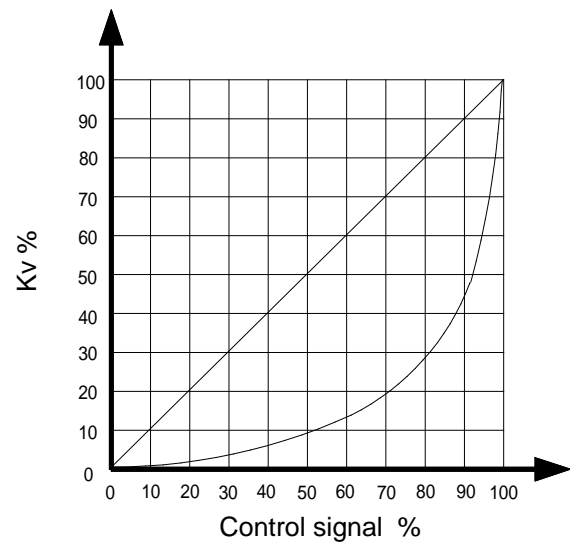
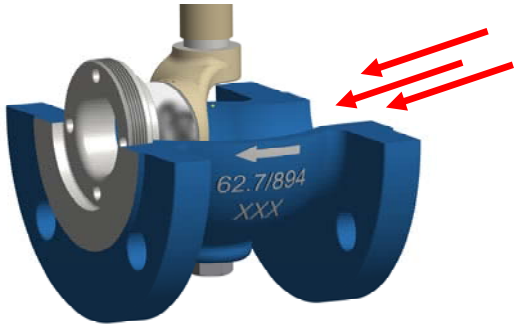

Fig. 7: Equal-percentage and linear characteristic

**Table1- Technical data - valve**

Maxifluss-Type	62.7	
Valve size	DN 25 to 200	NPS 1 to 8
Style	Flange	Flange
Flange pressure rating	PN 10 / 16 / 25 / 40	CL 150 / 300
Overall length	EN 558 series 36	EN 558 series 36
Flange bore/form	DIN EN 1092 B1	ASME B16.5
Flow Direction	 <p>FTC – flow to close</p>	
Characteristic	Equal percentage / linear / on/off	
Rangeability	up to 200 : 1	
Temperature range	medium: -60°C to +220°C / -76 °F to 428 °F	
Opening angle	90°	

**Table 2 - Materials**

Body	1.0619 / A216WCC	1.4408 / A351CF8M	1.5638 / A352LC3
Shaft	1.4404		
Plug	1.4408		
Disc back bar	1.4404		
Seat ring	1.4404 or soft seat		
Bushing	Polymer / Iglidur „X“		
Bonnet	1.4404		
Spring loaded packing	PTFE V ring packing - TA-Luft		

**Table 3 -  $K_{vs}$  and  $C_{vs}$  flow coefficient**
**Table3a - Seat with metal sealing - FTC (leakage according DIN EN 60534-4, KI IV G1)**

DN [mm] / NPS [in]		25/1	40/1 <sup>1/2</sup>	50/2	80/3	100/4	150/6	200/8
Seat factor 100%	$K_{vs}$ [m <sup>3</sup> /h]	14	33	58	194	276	474	721
	$C_{vs}$ [gpm]	16	38	67	224	319	548	834
	Seat Ø [mm]	18	26	36	60	76	105	135
Seat factor 40%	$K_{vs}$ [m <sup>3</sup> /h]	8	12	21	65	92	165	235
	$C_{vs}$ [gpm]	9,2	14	24	75	106	191	272
	Seat Ø [mm]	14	18,5	25,5	44	53	73	88

**Table 3b - Soft seat - FTC (Leakage according DIN EN 60534-4, KI VI G1)**

DN [mm] / NPS [in]		25/1	40/1 <sup>1/2</sup>	50/2	80/3	100/4	150/6	200/8
Seat factor 100%	$K_{vs}$ [m <sup>3</sup> /h]	11	28	68	177	318	466	678
	$C_{vs}$ [gpm]	13	32	79	205	368	539	784
	Seat Ø [mm]	14	23	35	55	70	95	125
Seat factor 40%	$K_{vs}$ [m <sup>3</sup> /h]	8	12	21	65	92	165	235
	$C_{vs}$ [gpm]	9,2	14	24	75	106	191	272
	Seat Ø [mm]	10	18,5	25,5	44	53	73	88

## Table 4 - Dimensions

### Table 4a - DIN face-to-face-dimensions

DN [mm]		25	40	50	80	100	150	200
PN 10	Length [mm]	102	114	124	165	194	229	243
PN 16								
PN 25								
PN 40								

### Table 4b - ANSI face-to-face-dimensions

NPS [in]		1	1 <sup>1/2</sup>	2	3	4	6	8
Class 150 Class 300	Length [in]	4,02	4,49	4,88	6,50	7,64	9,02	9,57

### Table 4c - Height H1

DN [mm] / NPS [in]		25/1	40/1 <sup>1/2</sup>	50/2	80/3	100/4	150/6	200/8
Height H1	[mm]	72	96	102	141	149	205	220
	[in]	2,83	3,78	4,02	5,55	5,87	8,07	8,66

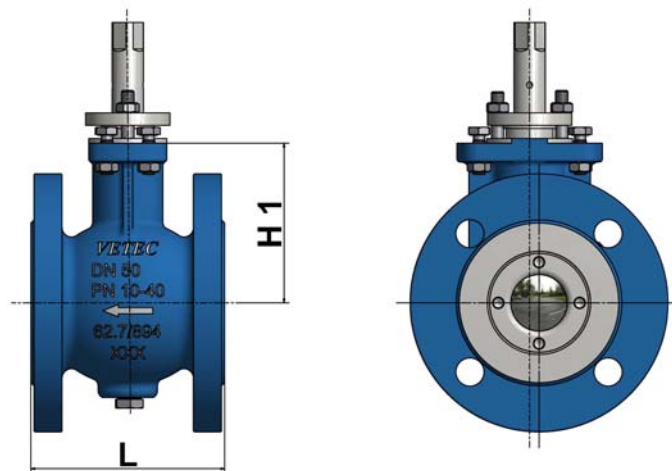

## Table 5 - Weight

### Valve without actuator and accessories

DN [mm] / NPS [in]		25/1	40/1 <sup>1/2</sup>	50/2	80/3	100/4	150/6	200/8
Weight	[kg]	5	7	9	19	26	46	67
	[lbs]	11,04	15,45	19,87	41,88	57,30	101,38	147,67

## Table 6 – Differential pressure

**Table 6a – Max. differential pressure for actuator [bar]**

DN / AT	60-4	100-4	150-4	220-4	300-4	450-4	600-4	900-4	1200-4	2000-4
25	16									
40		16								
50			16							
80				11,5	16					
100					8	14	16			
150						5	7	10	16	
200							3,5	5	8	16

**Table 6b – Max. differential pressure for actuator [psi]**

NPS / AT	60-4	100-4	150-4	220-4	300-4	450-4	600-4	900-4	1200-4	2000-4
1	232									
1 <sup>1/2</sup>		232								
2			232							
3				167	232					
4					116	203	232			
6						72	101	145	232	
8							51	72	116	232

### Order specifications

Type	Acc. to table 1
Valve size	DN / NPS.
Nominal pressure	PN / CL
Body material	Acc. to table 2
Seat version	Metal or soft sealing
Characteristic	equal percentage / linear / on/off
Kvs/Cv	Acc. to table 3
Direction of flow	FTC
Actuator	Type AT
Mounting	A / B / C / D
Fail-safe action	fail-close (FC) or fail-open (FO)
Max. differential pressure for actuator	Acc. to table 6
Supply air	4. bar
Bench range	... bar or mA
Accessories	positioner, limit switch, solenoid valve etc.
Others	test certificates customer inspection / technical documentation etc.