

Application

Steam-converting valve for power stations and industrial plants combined with a cooling water valve in one unit

Inlet	DN 40 to 500	• NPS 1½ to 20
	PN 16 to 630	• Class 150 to 2500
Outlet	DN 80 to 1600	• NPS 3 to 64
	PN 16 to 250	• Class 150 to 1500
Temperatures	Up to 560 °C	• Up to 1040 °F

Steam-converting valve with

- Type 3271 Pneumatic Actuator
- Type 3277 Pneumatic Actuator (see Data Sheets
▶ T 8310-1 EN and ▶ T 8310-2 EN)

Valve body made of

- Forged steel C22.8, A105
- Heat-resisting forged steel 16Mo13, 13CrMo44, 10CrMo910, A182 F2, A182 F12, A182 F22

Special features

- Perforated plug with controlled pressure reduction in two stages
- One or more attenuation plates providing uncontrolled pressure reduction
- Integrated atomizer unit
- Welding ends
- Angle-style body permits vertical stem orientation
- Balanced or unbalanced perforated plug

Version

- **Standard version** · Angle valve body with welding ends for steam temperatures up to 560 °C (1040 °F)
- Nominal **inlet** size DN 40 to 500 (NPS 1½ to 20), nominal pressure PN 16 to 630 (Class 150 to 2500)
- Nominal **outlet** size DN 80 to 1600 (NPS 3 to 64), nominal pressure PN 16 to 250 (Class 150 to 1500)

Further versions

- Flanges
- Electric actuators
- Hydraulic actuators
- Globe-style body (see Fig. 4 and Fig. 5)

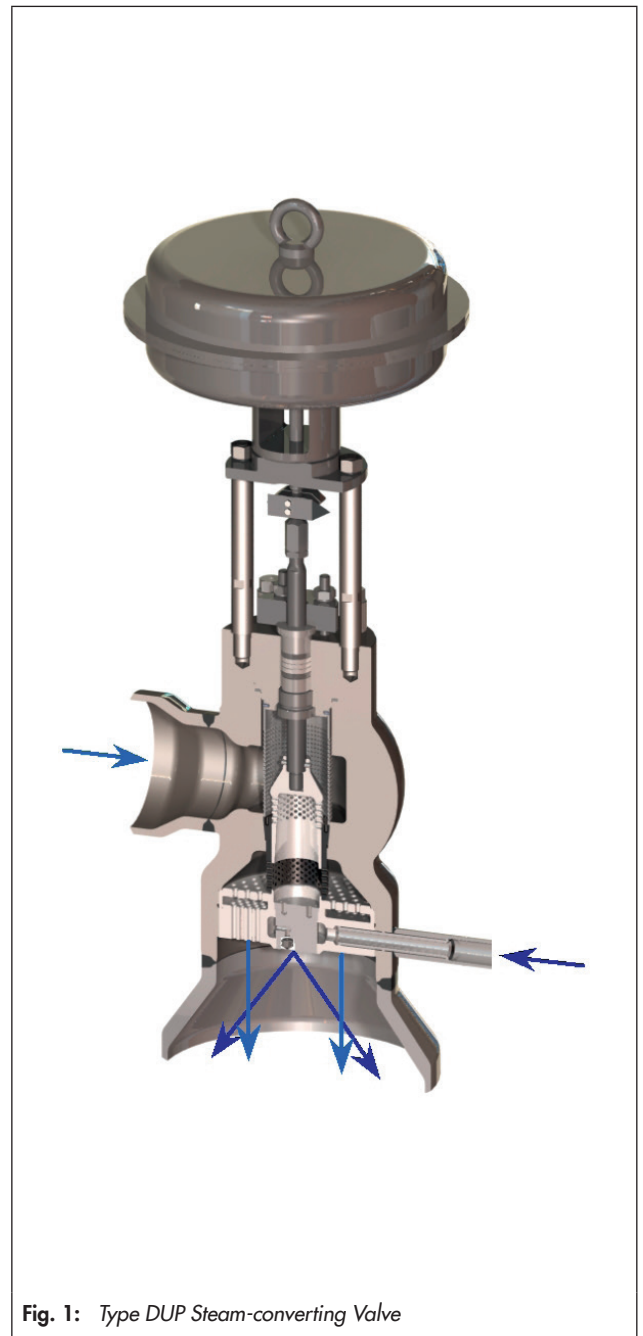

Fig. 1: Type DUP Steam-converting Valve

Principle of operation

When the perforated plug (1) leaves its closed position and the steam inlet holes (2) of the first stage of controlled pressure reduction are opened, a certain amount of steam flows through these holes.

This special amount of steam passes directly through axial holes in the atomizing unit (3) and is used to atomize the cooling water (4). The second stage (5) is first released when the required amount of atomizing steam is achieved.

As the perforated plug continues to lift, more steam inlet holes are released in a pattern corresponding to the desired opening characteristic.

In short, the perforated plug is used to control the pressure and flow rate of steam.

After the second stage of controlled pressure reduction, the steam impinges on the attenuation plates (6), causing a further pressure reduction and reducing the overall noise.

After exiting the last attenuation plate, any steam that has not yet been cooled is cooled by the fine atomized mixture of cooling water and atomizing steam.

The temperature sensor located at a suitable distance downstream on the valve outlet measures the steam temperature at that point. The temperature signal is fed back to the cooling water valve used to regulate the flow rate of cooling water to achieve the required temperature set point.

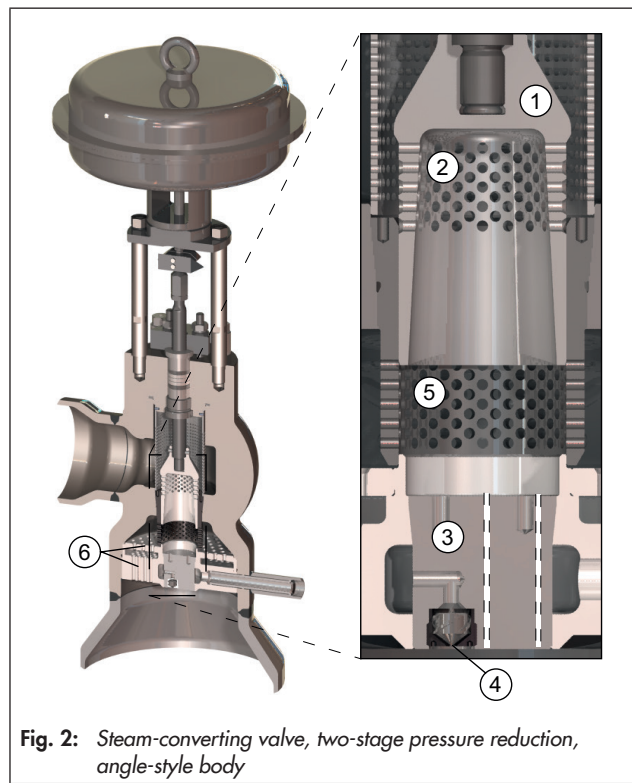

Fig. 2: Steam-converting valve, two-stage pressure reduction, angle-style body

Table 1: Technical data

Type DUP	All valve sizes				
Body material	DIN	1.0460	1.5415	1.7335	1.7380
	ASTM	A105	A182 F2	A182 F12	A182 F22
Pressure rating	All pressure ratings				
Type of end connections	Flanges · Welding ends				
Closure member	Two-stage perforated plug and one or more attenuation plates (depending on total pressure drop)				
Seat/plug seal	Metal seal				
Characteristic	Linear · Modified				
Materials and temperature ranges					
Body	450 °C	500 °C	560 °C	560 °C	
Seat and plug	1.4122: up to 500 °C · 1.4922: up to 560 °C				
Guide bushing	1.4122: up to 400 °C · 1.7380, 1.4922, 1.4903: up to 560 °C				
Packing	Graphite braid and graphite strip				
Body gasket	Spiral wound gasket				
Leakage class					
Metal-seated plug	D – according to DIN EN 12266-1				
	IV – according to ANSI B16.104				

Table 2: K_{VS} coefficients in relation to the seat and travel

K_{VS}	m^3/h	10	20	35	55	70	100	170	235	400	600	850	1140
Seat \varnothing	mm	30	40	50	60	70	80	100	120	150	180	210	240
Travel	mm	30			60			120					

Table 3: Dimensions in mm and weights in kg

Seat Ø (mm)	Inlet ¹⁾		Outlet ¹⁾		Cooling water		Dimensions in mm (Fig. 3)				Actuator ²⁾ Type – cm ²	Valve weight ³⁾ kg (approx.)
	DN	NPS	DN	NPS	DN	NPS	A ⁴⁾	B	C ⁴⁾	D		
30	40	1½	150	6	25	1	250 to 350	175	120 to 200	200	u 3271 – 700 3277 – 355 3277 – 700	120
	50	2	200	8								
	65	2½	250	10								
	80	3	300	12								
100	4											
40	50	2	150	6	25	1	250 to 350	175	120 to 200	200	u 3271 – 700 3277 – 355 3277 – 700	120
	65	2½	200	8								
	80	3	250	10								
	100	4	300	12								
50	65	2½	150	6	25	1	250 to 350	175	120 to 200	200	u 3271 – 700 3277 – 355 3277 – 700 3271 – 1400	150
	80	3	200	8								
	100	4	250	10								
	125	5	300	12								
60	65	2½	150	6	25	1	250 to 350	175	120 to 200	200	u 3271 – 700 3277 – 355 3277 – 700 3271 – 1400	150
	80	3	200	8								
	100	4	250	10								
	125	5	300	12								
70	80	3	200	8	25	1	350 to 475	275	150 to 250	250	u-e 3271 – 1400	300
	100	4	250	10								
	125	5	300	12								
	150	6	350	14								
	200	8	400	16								
			500	20								
80	100	4	200	8	25	1	350 to 475	275	150 to 250	250	u-e 3271 – 1400	300
	125	5	250	10								
	150	6	300	12								
	200	8	350	14								
			400	16								
			500	18								
100	100	4	200	8	40	1½	375 to 500	300	175 to 275	275	u-e 3271 – 1400	400
	125	5	250	10								
	150	6	300	12								
	200	8	350	14								
			400	16								
			500	20								
120	150	6	250	10	40	1½	375 to 500	300	175 to 275	275	u-e 3271 – 1400	400
	200	8	300	12								
	250	10	350	14								
			400	16								
			500	20								
			600	24								
150	200	8	400	16	40	1½	575 to725	450	250 to 450	450	e 3271 – 1400 3271 – 2800	1400
	250	10	500	20								
	300	12	600	24								
			700	28								
			800	32								

Seat Ø (mm)	Inlet ¹⁾		Outlet ¹⁾		Cooling water		Dimensions in mm (Fig. 3)				Actuator ²⁾ Type – cm ²	Valve weight ³⁾ kg (approx.)
	DN	NPS	DN	NPS	DN	NPS	A ⁴⁾	B	C ⁴⁾	D		
180	250	10	400	16	40	1½	575 to 725	450	250 to 450	450	e 3271 – 1400 3271 – 2800	1400
	300	12	500	20								
	350	14	600	24								
			700	28								
800	32											
210	250	10	400	16	40	1½	600 to 750	475	300 to 500	500	e 3271 – 1400	2000
	300	12	500	20								
	350	14	600	24								
			700	28								
800	32											
240	250	10	400	16	40	1½	600 to 750	475	300 to 500	500	e 3271 – 1400 3271 – 2800	2000
	300	12	500	20								
	350	14	600	24								
			700	28								
800	32											

1) Nominal inlet and outlet sizes can be combined as required

2) Recommended actuator: u Unbalanced perforated plug · e Balanced perforated plug

3) Valve weight without actuator

4) Small dimension: no weld-end socket at the outlet · Large dimension: weld-end socket at the outlet

Dimensional drawing

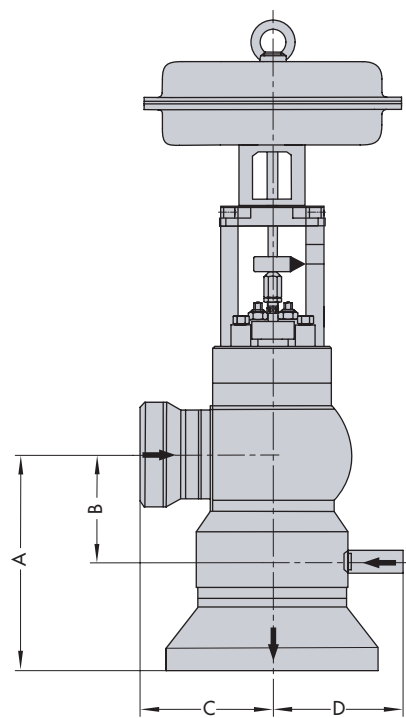

Fig. 3: Type DUP Steam-converting Valve

Further versions

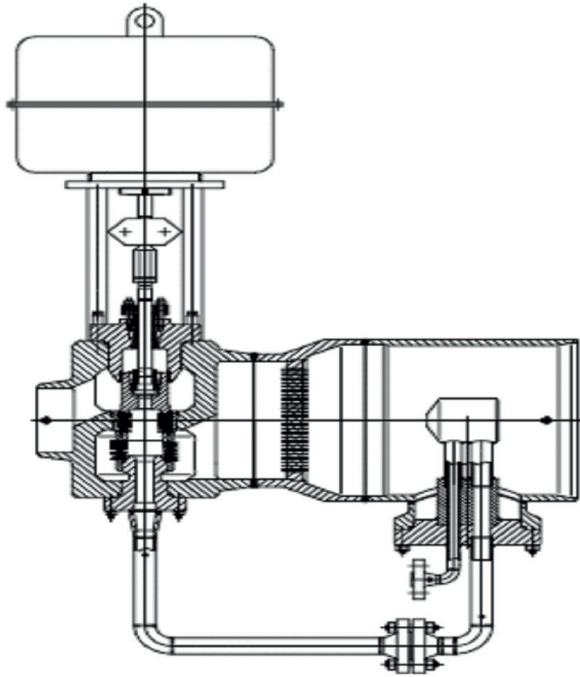

Fig. 4: Steam-converting valve (globe-style body)

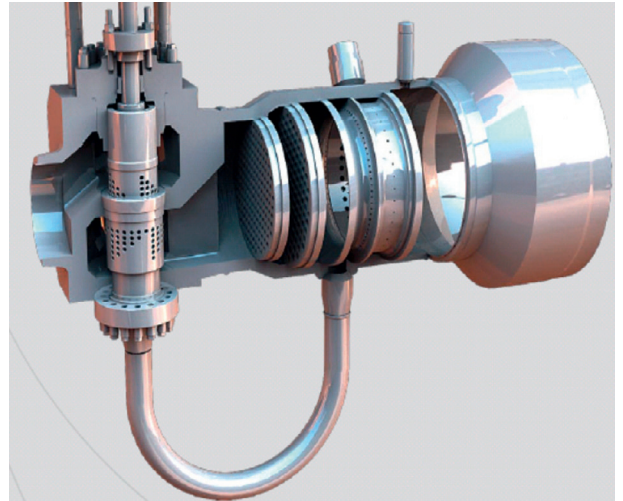

Fig. 5: Steam-converting valve (globe-style body) with injection of large quantities of water

Cooling water valve

Application

Regulation of the flow rate of cooling water for the Type DUP Steam-converting Valve

Valve size	DN 15 to 80 NPS ½ to 3
Pressure rating	PN 25 to 400 Class 150 to 2500
Medium temperature	Up to 220 °C · Up to 430 °F

Globe valve with

- Type 3271 Pneumatic Actuator
- Type 3277 Pneumatic actuator for direct attachment of a positioner or limit switch

Valve body made of

- Forged steel C22.8/ A105
- Heat-resisting forged steel 16Mo3/A182 F2

Versions

Standard version · Globe valve with welding ends, controlled pressure reduction in one to four stages, PTFE/graphite packing, equal percentage characteristic

Further versions

- Body with flanges
- Angle-style body
- Medium temperatures above 220 °C on request
- Linear or modified linear characteristic
- Electric actuators
- Hydraulic actuators

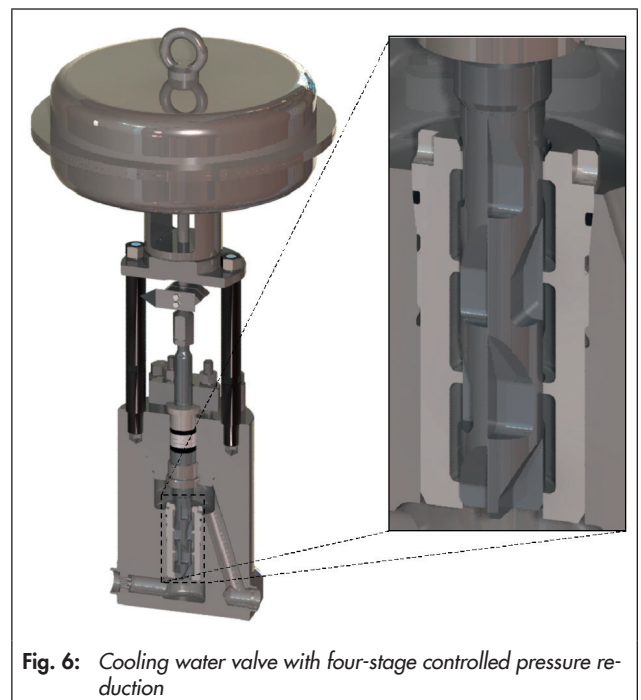

Fig. 6: Cooling water valve with four-stage controlled pressure reduction

Note:

- The cooling water valve belonging to the steam-converting valve is part of the steam converter unit.
- The cooling water valve is sized taking all load cases of the station into account. If the cooling water valve is ordered separately, SAMSON cannot guarantee proper temperature regulation of the steam-converting valve.

Specifications subject to change without notice



SAMSON AG · MESS- UND REGELTECHNIK
Weismüllerstraße 3 · 60314 Frankfurt am Main, Germany
Phone: +49 69 4009-0 · Fax: +49 69 4009-1507
samson@samson.de · www.samson.de

T 9944 EN

2015-03-02 · English