

Type 994 - 0001 Water Bath Desuperheater

for desuperheating superheated steam to saturated steam temperature

General

Water bath desuperheaters are used if processes have to be heated with saturated steam, but where only superheated steam is available which must be desuperheated to saturated steam temperature. This is not possible with steam converting valves or injection desuperheaters, since it is possible to desuperheat only down to approx. 5 °C above saturated steam temperature with these. If the pressure of the available steam is too high or an adjustable saturated steam pressure is required, the water bath desuperheater can be designed in addition with pressure control.

Processes which are heated with saturated steam frequently require only small quantities of steam, but with delivery fluctuations between 0 and 100%. Here the water bath desuperheater is ideally suitable, since it guarantees perfect desuperheating over the entire load range.

Applications in which the product has to be heated directly with saturated steam are for example:

- Agers and decatizing vessels in the textile industry
- Pasteurizers in the food industry
- Sterilizers in the chemical industry
- Steam boxes in the paper industry

Applications in which the products have to be heated through heat exchanger surfaces where overheating of the product must be surely avoided are for example:

- Heat exchangers for pasteurizers and sterilizers in the food industry
- Heating systems for dry rolls in the paper industry
- Heating systems for reaction vessels and pipelines in the chemical industry

The Type 994 - 0001 water bath desuperheater has the following features:

- Desuperheating superheated steam to saturated steam temperature
- Pressure reduction of superheated steam
- Control range 0 ... 100 %
- Operating overpressure max. 11 bar, higher pressure on request
- Saturated steam pressure max. 11 bar, higher pressure on request
- Saturated steam temperature max. 187 °C
- Steam throughput max. 40t/h, depending on the saturated steam pressure
- Pressure vessel made from H11 (mat. no. 1.0425) or CrNiTi (mat. no. 1.4541)
- Pressure vessel with German Technical Inspectorate Certificate, other certificates on request
- Version with fastening supports
- Version with liquid level control
- Version with liquid level control and pressure control
- Version with liquid level control, pressure control and process temperature control
- Version as complete system, ready for connection assembled in a frame

Construction

The Type 994 - 0001 water bath desuperheater consists of a pressure vessel [1], which is protected against thermal losses with an insulation [2]. The superheated steam flows from above through a pipe [7] into the interior of a flow divider [4], which is com-



Fig. 1

Construction

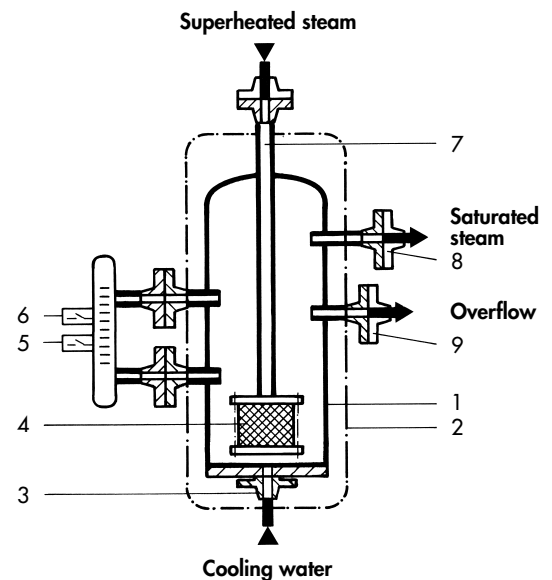

Fig. 2

pletely surrounded by cooling water. The cooling water is fed in from below through a pipe [3] into the pressure vessel [1]. The steam arising bubbles out from the flow divider [4] at the water surface and escapes as saturated steam. The saturated steam is carried out from the pressure vessel [1] through a pipe [8]. The liquid level of the cooling water is monitored with two limit switches [5] and [6]. An overflow [9] is fitted above the maximum liquid level in order to avoid overfilling of the pressure vessel [1] on failure of the liquid level control system.

Operation

Water bath desuperheater with liquid level control

The superheated steam is introduced into the cooling water. In this case the superheating heat is transferred into the cooling water which is converted into saturated steam when the boiling temperature is reached. The evaporated portion is replaced by cooling water with a liquid level control system. On reaching the minimum liquid level, the condensate valve [1.4] is opened via a limit switch [1.3] and closed when the maximum liquid level is reached. On failure of the liquid level control system the cooling water is diverted through a condensate diverter [1.6].

Pressure regulation

Saturated steam pressure and saturated steam temperature are associated with one another physically. In the version with pressure regulation, the saturated steam pressure is converted into a measurement signal which is conducted to a pressure controller [2.3] through a pressure transmitter [2.2]. The output signal of the pressure controller [2.3] operates the steam pressure control valve [2.5] through a positioner [2.4]. Thus the pressure of the superheated steam can be reduced and cooled to desuperheated steam temperature.

Process temperature control

In the version with process temperature control the measurement signal of a temperature sensor [3.1] is conducted to a temperature controller [3.2], the output signal of which operates the temperature control valve [3.4] through a positioner [3.3]. In this case the pressure drop at the temperature control valve [3.4] must be kept low so that the saturated steam temperature is as close as possible to the load temperature to be controlled.

Safety equipment

The operating pressure in the pressure vessel [1.1] of the water bath desuperheater is limited to the permissible value by means of a safety valve [2.6.3]. A safety pressure limiter [2.7.1] and a safety temperature limiter [2.7.2] ensure that the pressure and temperature at the saturated steam outlet do not exceed the permissible values. Whenever the pressure and temperature reach the respective limit values, the steam pressure control valve [2.5] is closed via a solenoid valve [2.7.3].

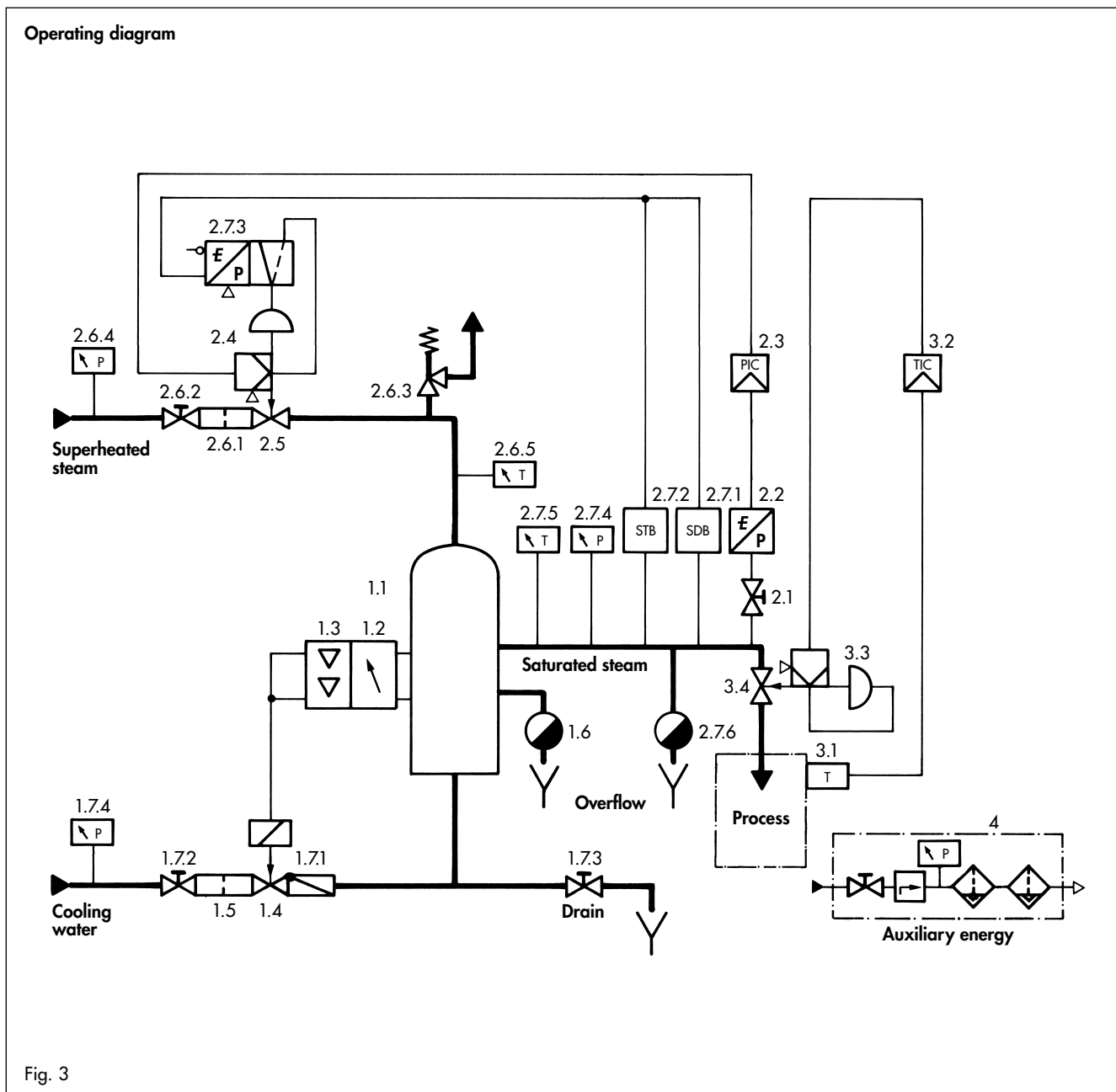

Versions and ordering data

Versions (Fig. 3)

1. Water bath desuperheater with liquid level control

- 1.1 Pressure vessel made from material
 - HII (mat. no. 1.0425)
 - CrNiTi (mat. no. 1.4541)
- 1.2 Liquid level meter
- 1.3 Limit switch
- 1.4 Condensate valve
- 1.5 Strainer
- 1.6 Condensate diverter
- 1.7 In addition for the cooling water feed
 - 1.7.1 Non-return valve
 - 1.7.2 Manual shut-off valve "inlet"
 - 1.7.3 Manual shut-off valve "emptying"
 - 1.7.4 Pressure gauge

2. Pressure regulation

- 2.1 High pressure shut-off valve with without
- 2.2 Pressure transmitter
- 2.3 Pressure controller
- 2.4 Positioner
- 2.5 Steam pressure control valve
- 2.6 In addition for the steam inlet
 - 2.6.1 Strainer
 - 2.6.2 Manual shut-off valve
 - 2.6.3 Safety valve
 - 2.6.4 Pressure gauge
 - 2.6.5 Thermometer
- 2.7 In addition for the steam outlet
 - 2.7.1 Safety pressure limiter
 - 2.7.2 Safety temperature limiter
 - 2.7.3 Solenoid valve (in addition for 2.7.1 or 2.7.2)
 - 2.7.4 Pressure gauge
 - 2.7.5 Thermometer
 - 2.7.6 Condensate diverter

3. Process temperature control

- 3.1 Temperature sensor with without
- 3.2 Temperature controller
- 3.3 Positioner
- 3.4 Temperature control valve

4. Service unit

with without

5. Control cabinet

with without

6. Frame

with without

7. Insulation for pressure vessel

with without

Operating data

Superheated steam

$p1_{\min} = \dots \text{ bar}_{\text{abs}}$
 $t1_{\min} = \dots \text{ }^\circ\text{C}$

$p1_{\max} = \dots \text{ bar}_{\text{abs}}$
 $t1_{\max} = \dots \text{ }^\circ\text{C}$

Saturated steam

$p2_{\min} = \dots \text{ bar}_{\text{abs}}$
 $q_{m \min} = \dots \text{ kg/h}$

$p2_{\max} = \dots \text{ bar}_{\text{abs}}$
 $q_{m \max} = \dots \text{ kg/h}$

Cooling water

- Drinking water
- Boiler feed water
- Boiler feed water, desalinated
-

$p3_{\min} = \dots \text{ bar}_{\text{abs}}$
 $t3_{\min} = \dots \text{ }^\circ\text{C}$

$p3_{\max} = \dots \text{ bar}_{\text{abs}}$
 $t3_{\max} = \dots \text{ }^\circ\text{C}$

Instrumentation

- pneumatic
- electropneumatic
- electronic, with electrical servo drives

Auxiliary energy

Instrument air
 $U = \dots \text{ V}$

$p = \dots \text{ bar}$
 $f = \dots \text{ Hz}$

Installation examples

Heating agers in the textile industry (Fig. 4)

Statement of the problem

An ager for coloured textile webs has to be heated with steam in a temperature range of 100 to 110 °C. The steam may only be slightly overheated in order to avoid stains forming on the textile webs at the entry places into the ager. In addition, the steam must be dry so that no water stains can occur.

Solution of the problem

Superheated steam is reduced in pressure and desuperheated to saturated steam temperature in a water bath desuperheater with liquid level control and electropneumatic pressure regulation. The cooling water is fed into the pressure vessel from a separate water network. The temperature of the ager is kept constant even on load changes (e.g. changing running speeds or changing specific weight of the textile webs) with a process temperature control. The maximum temperature of the ager is limited by the set saturated steam pressure. In order to avoid overheating of the ager in the case of the fault, the temperature control valve is designed for a slight pressure drop so that the saturated steam temperature is as close as possible to the ager temperature to be controlled. The components of the water bath desuperheater are installed in a frame ready for connection as complete system.

Heating vessels and pipelines in the chemical industry (Fig. 5)

Statement of the problem

The vessel and the pipelines of a SO_3 -conditioning plant have to be heated with steam and the heating temperature must be kept within tight limits. The condensate arising on heating should be used as cooling medium.

Solution of the problem

Superheated steam is reduced in pressure and desuperheated to saturated steam temperature in a water bath desuperheater with liquid level control and electropneumatic pressure regulation. The hot condensate arising on heating the vessel and the pipelines is conducted into a pressureless collecting vessel and cooled down by the ambient air. Excess condensate is delivered to the condensate network through an overflow. The flash steam arising on condensate diversion is diverted over the roof. The cooled condensate is fed into the pressure vessel of the water bath desuperheater as cooling medium using cooling water pressure elevating pumps. Thus the collecting vessel has to be filled with cooling water only before the first time the plant is started up. A safety pressure limiter is installed at the steam inlet and a safety limiter at the steam outlet to protect the plant. The cooling water pressure elevating pumps are equipped with dry running protection and automatic fault switchover. The components of the water bath desuperheater are installed in a frame ready for connection as complete system.

(Subject to modification)

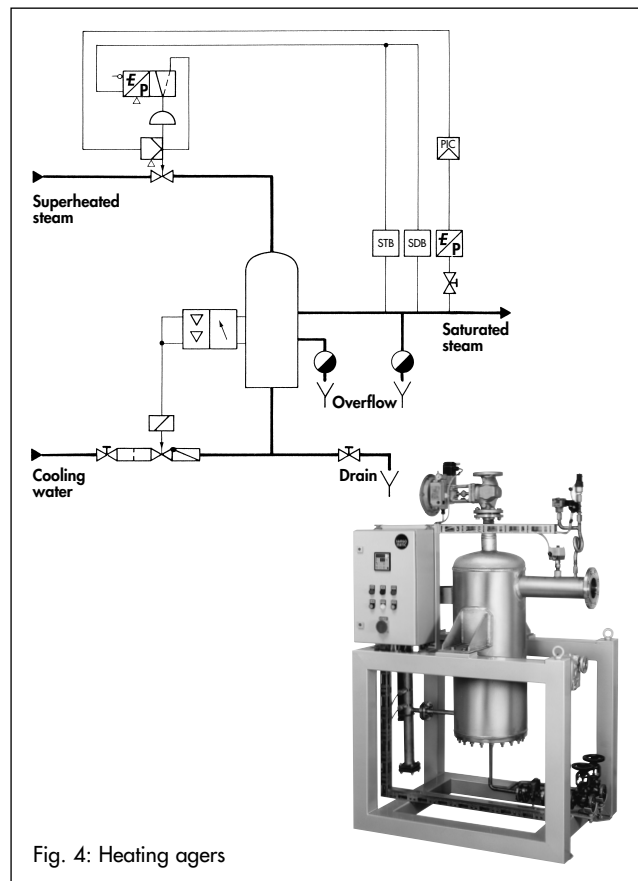

Fig. 4: Heating agers

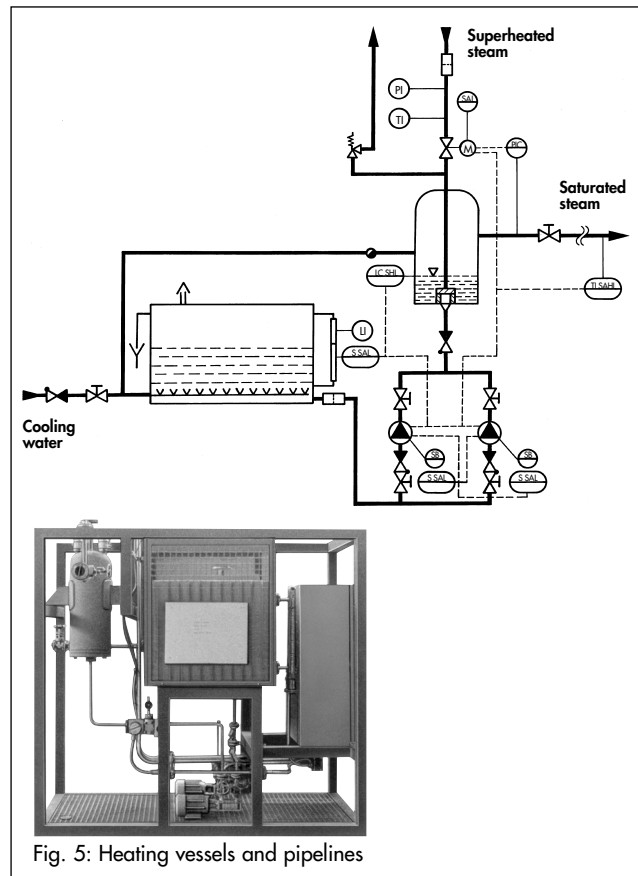

Fig. 5: Heating vessels and pipelines

SAMSOMATIC GMBH

Weismüllerstraße 20-22
60314 Frankfurt am Main · Germany

Phone: +49 69 4009-0
Fax: +49 69 4009-1644
E-mail: samsomatic@samson.de
Internet: <http://www.samsomatic.de>