



PERFORMANCE RANGE

- Flow rate up to **60 l/min** (3.6 m³/h)
- Head up to **48 m**

APPLICATION LIMITS

- Manometric suction lift up to **9 m** (HS)
- Liquid temperature between **-10 °C** and **+40 °C**
- Ambient temperature up to **+40 °C**
- Max. working pressure **6 bar**
- Continuous service **S1**

CONSTRUCTION AND SAFETY STANDARDS

EN 60335-1
IEC 60335-1
CEI 61-150

EN 60034-1
IEC 60034-1
CEI 2-3



CERTIFICATIONS

Company with management system certified DNV
ISO 9001: QUALITY
ISO 14001: ENVIRONMENT

INSTALLATION AND USE

Suitable for use with clean water and with liquids that are not chemically aggressive towards the materials from which the pump is made. The self-priming **JCR** pumps are designed to pump water even in cases where air is present. Because of their reliability and the fact that they are easy to use, they are recommended for use in domestic applications such as the distribution of water in combination with small or medium sized pressure tanks, and for the irrigation of gardens and orchards, etc. The pump should be installed in an enclosed environment or sheltered from inclement weather.

PATENTS - TRADE MARKS - MODELS

- European Patent n. 1 510 696

OPTIONS AVAILABLE ON REQUEST

- Pump body with NPT ANSI B 1.20.1 threaded ports
- Other voltages

GUARANTEE

2 years subject to terms and conditions

CHARACTERISTIC CURVES AND PERFORMANCE DATA

60 Hz n= 3450 rpm HS= 0 m

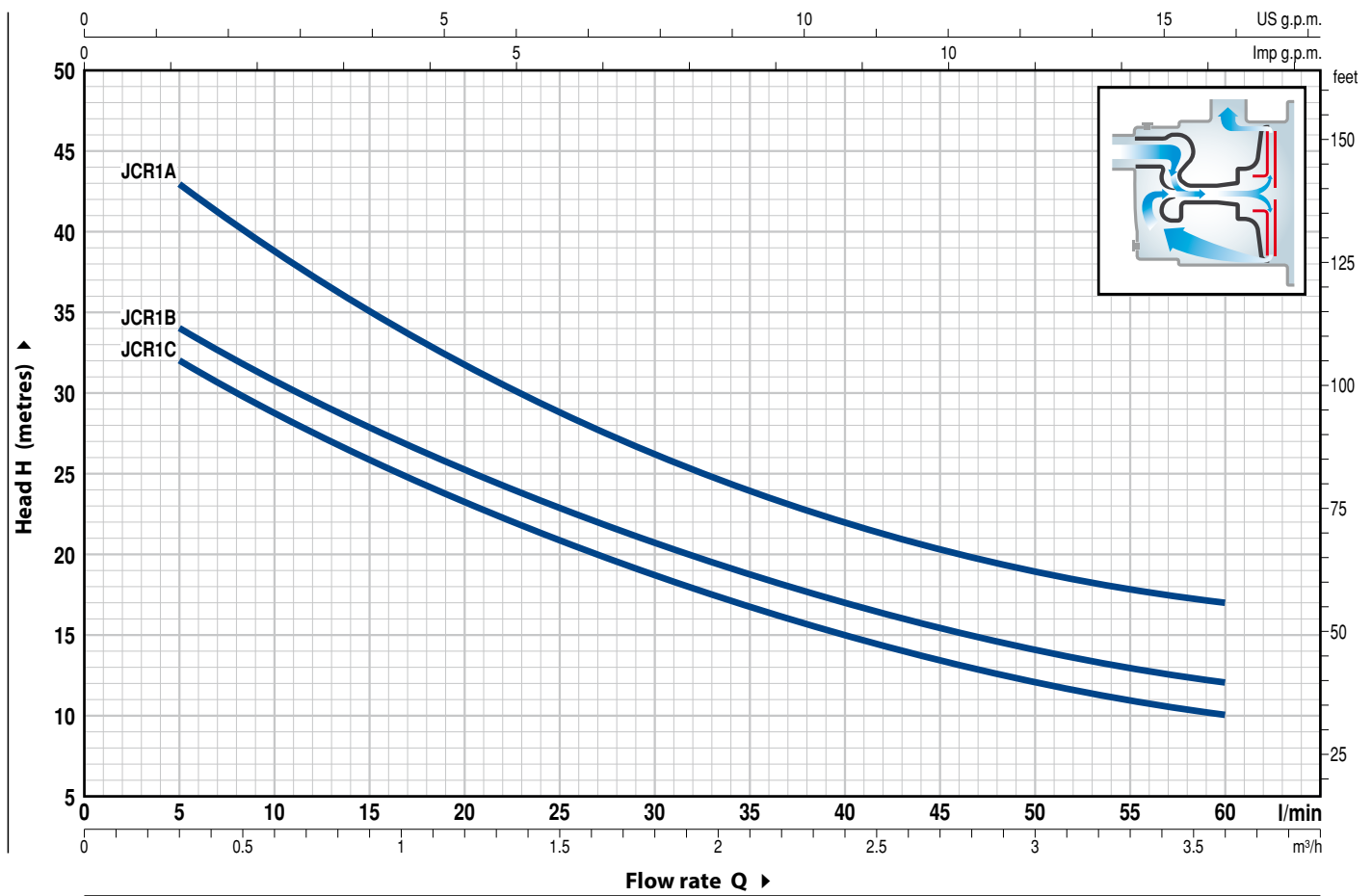

MODEL		POWER (P ₂)		Q	Flow rate										
Single-phase	Three-phase	kW	HP		m ³ /h	0	0.3	0.6	1.2	1.5	1.8	2.4	2.7	3.0	3.6
				l/min	0	5	10	20	25	30	40	45	50	60	
JCRm 1C	JCR 1C	0.37	0.50	H metres	35	32	28.5	23.5	21	18.5	15	13.5	12	10	
JCRm 1B	JCR 1B	0.48	0.65		37	34	30.5	25.5	23	20.5	17	15.5	14	12	
JCRm 1A	JCR 1A	0.55	0.75		48	43	39	31.5	28.5	26	22	20.5	19	17	

Q = Flow rate H = Total manometric head HS = Suction height

Tolerance of characteristic curves in compliance with EN ISO 9906 Grade 3B.

STANDARD INSTALLATION

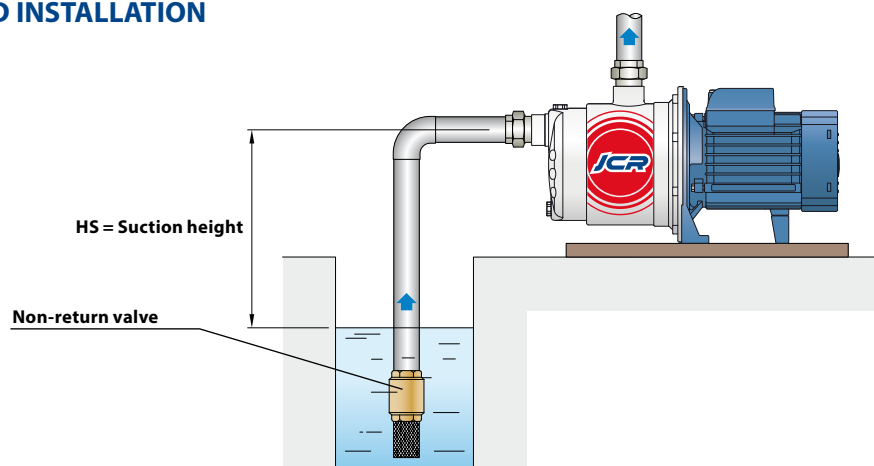

POS. COMPONENT CONSTRUCTION CHARACTERISTICS

1	PUMP BODY	Stainless steel AISI 304 complete with threaded ports in compliance with ISO 228/1				
2	BODY BACKPLATE	Stainless steel AISI 304				
3	NOZZLE ASSEMBLY	Noryl FE1520PW				
4	IMPELLER	Stainless steel AISI 304				
5	MOTOR SHAFT	Stainless steel EN 10088-3 - 1.4104				
6	MECHANICAL SEAL	<i>Seal Model</i>	<i>Shaft Diameter</i>	<i>Stationary ring</i>	<i>Materials Rotational ring</i>	<i>Elastomer</i>
		AR-12	Ø 12 mm	Ceramic	Graphite	NBR
7	BEARINGS	6201 ZZ / 6201 ZZ				
8	CAPACITOR	<i>Pump Single-phase</i>	<i>Capacitance (220 V)</i>	<i>(110 V or 127 V)</i>		
		JCRm 1C	10 µF - 450 VL	25 µF - 250 VL		
		JCRm 1B	10 µF - 450 VL	25 µF - 250 VL		
		JCRm 1A	14 µF - 450 VL	25 µF - 250 VL		

9 ELECTRIC MOTOR **JCRm:** single-phase 220 V - 60 Hz with thermal overload protector incorporated into the winding.
JCR: three-phase 220/380 V - 60 Hz or 220/440 V - 60 Hz.
⇒ The three-phase pumps are fitted with high performance motors in class IE2 (IEC 60034-30)

- Insulation: class F
- Protection: IP X4

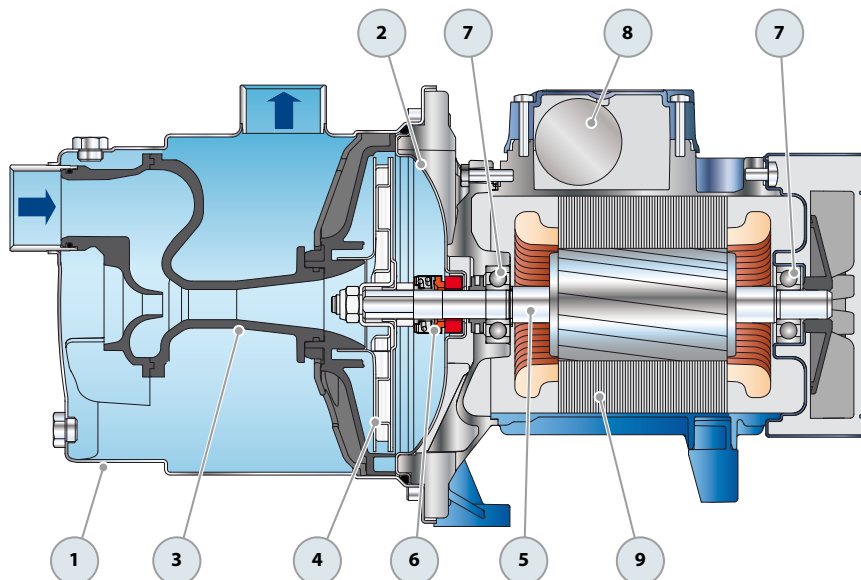

DIMENSIONS AND WEIGHT

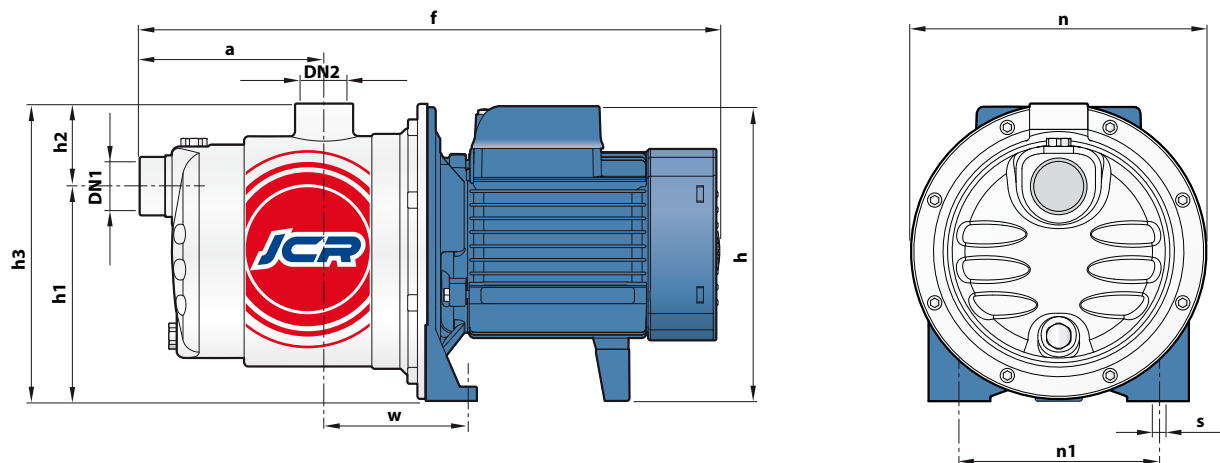

MODEL		PORTS		DIMENSIONS mm										kg	
Single-phase	Three-phase	DN1	DN2	a	f	h	h1	h2	h3	n	n1	w	s	1~	3~
JCRm 1C	JCR 1C	1"	1"	113	361	182	132	51	183	182	120	87	9	7.1	7.1
JCRm 1B	JCR 1B													7.2	7.2
JCRm 1A	JCR 1A													7.8	7.2

ABSORPTION

MODEL	VOLTAGE		
	220 V	110 V	127 V
Single-phase	220 V	110 V	127 V
JCRm 1C	3.0 A	6.0 A	5.6 A
JCRm 1B	3.3 A	6.6 A	6.2 A
JCRm 1A	4.0 A	8.0 A	7.3 A

MODEL	VOLTAGE			
	220 V	380 V	220 V	440 V
Three-phase	220 V	380 V	220 V	440 V
JCR 1C	2.0 A	1.15 A	2.1 A	1.3 A
JCR 1B	2.3 A	1.3 A	2.1 A	1.3 A
JCR 1A	3.1 A	1.8 A	2.6 A	1.5 A

PALLETIZATION

MODEL		GROUPAGE	CONTAINER
Single-phase	Three-phase	n. pumps	n. pumps
JCRm 1C	JCR 1C	84	120
JCRm 1B	JCR 1B	84	120
JCRm 1A	JCR 1A	84	120