

2-5CR

Multi-stage centrifugal pumps

-  Clean water
-  Domestic use
-  Civil use



PERFORMANCE RANGE

- Flow rate up to **130 l/min** (7.8 m³/h)
- Head up to **67 m**

APPLICATION LIMITS

- Manometric suction lift up to **7 m**
- Liquid temperature between **-10 °C** and **+40 °C**
- Ambient temperature up to **+40 °C**
- Max. working pressure **7 bar**
- Continuous service **S1**

CONSTRUCTION AND SAFETY STANDARDS

EN 60335-1
IEC 60335-1
CEI 61-150

EN 60034-1
IEC 60034-1
CEI 2-3



CERTIFICATIONS

Company with management system certified DNV
ISO 9001: QUALITY
ISO 14001: ENVIRONMENT

INSTALLATION AND USE

Suitable for use with clean water and with liquids that are not chemically aggressive towards the materials from which the pump is made. As a result of their quietness these pumps are widely used in domestic applications such as the distribution of water in combination with small and medium sized pressure tanks, and for the irrigation of gardens and orchards, etc.

The pump should be installed in an enclosed environment or sheltered from inclement weather.

OPTIONS AVAILABLE ON REQUEST

- Pump body with NPT ANSI B 1.20.1 threaded ports
- Special mechanical seal
- Other voltages

GUARANTEE

2 years subject to terms and conditions

CHARACTERISTIC CURVES AND PERFORMANCE DATA

60 Hz n= 3450 rpm HS= 0 m

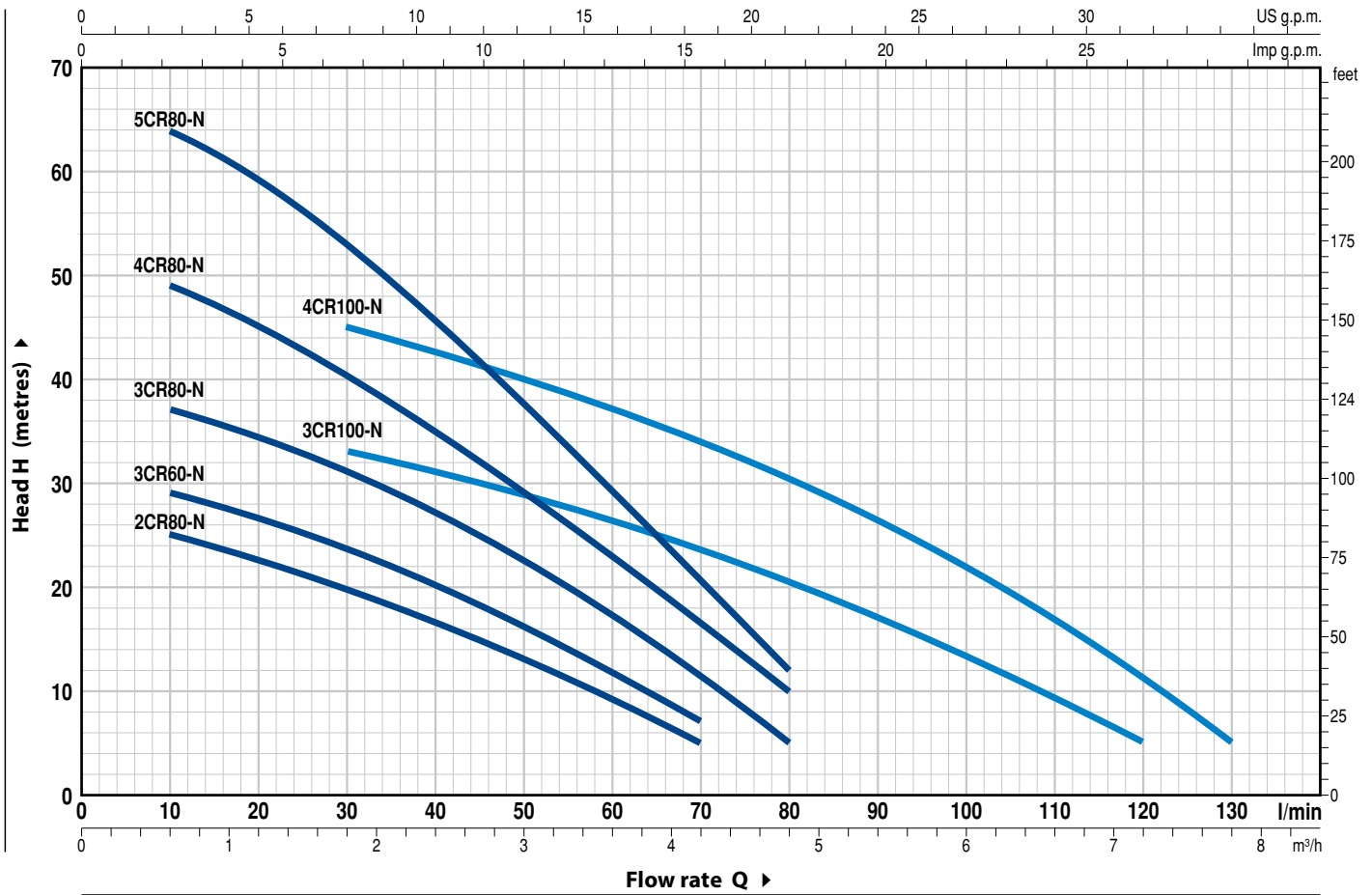

MODEL		POWER (P ₂)		Q	H metres																		
Single-phase	Three-phase	kW	HP		m ³ /h	0	0.3	0.6	0.9	1.2	1.5	1.8	2.4	3.0	3.6	4.2	4.8	5.4	6.0	6.6	7.2	7.8	
				l/min	0	5	10	15	20	25	30	40	50	60	70	80	90	100	110	120	130		
2CRm 80 -N	2CR 80 -N	0.37	0.50	H metres	27	26	25	24	22.5	21	20	16.5	13	9	5								
3CRm 60 -N	3CR 60 -N	0.37	0.50		31	30	29	28	26.5	25	23.5	20	16	11.5	7								
3CRm 80 -N	3CR 80 -N	0.45	0.60		40	38	37	36	34.5	33	31	27	22.5	17	11	5							
4CRm 80 -N	4CR 80 -N	0.55	0.75		52	50	49	47	44.5	42	40	34	28.5	22.5	16	10							
5CRm 80 -N	5CR 80 -N	0.75	1		67	66	64	62	59	56	53	45.5	37.5	29.5	20.5	12							
3CRm 100-N	3CR 100-N	0.55	0.75		38	37	36	35	34.5	33.5	33	31	28	26	23	20	17	13.5	10	5			
4CRm 100-N	4CR 100-N	0.75	1		50	50	49	48	47	46	45	42	39.5	37	34	30.5	26.5	22	17	11	5		

Q = Flow rate H = Total manometric head HS = Suction height

Tolerance of characteristic curves in compliance with EN ISO 9906 Grade 3B.

2-5CR

POS. COMPONENT CONSTRUCTION CHARACTERISTICS

1	PUMP BODY	Stainless steel AISI 304 complete with threaded ports in compliance with ISO 228/1				
2	BODY BACKPLATE	Stainless steel AISI 304				
3	IMPELLERS	Noryl FE1520PW				
4	DIFFUSERS	Noryl complete with anti-wear ring				
5	MOTOR SHAFT	Stainless steel EN 10088-3 - 1.4104				
6	MECHANICAL SEAL	<i>Seal Model</i>	<i>Shaft Diameter</i>	<i>Stationary ring</i>	<i>Materials Rotational ring</i>	<i>Elastomer</i>
		AR-13	Ø 13 mm	Ceramic	Graphite	NBR
7	BEARINGS	<i>Pump</i>	<i>Model</i>			
		2CR 80 -N 3CR 60 -N 3CR 80 -N 4CR 80 -N 3CR 100-N 4CR 100-N 5CR 80 -N	6202 ZZ - C3 / 6201 ZZ 6203 ZZ / 6203 ZZ			
8	CAPACITOR	<i>Pump Single-phase</i>	<i>Capacitance (220 V)</i>	<i>(110 V or 127 V)</i>		
		2CRm 80 -N 3CRm 60 -N 3CRm 80 -N 4CRm 80 -N 3CRm 100-N 4CRm 100-N 5CRm 80 -N	10 µF - 450 VL 12.5 µF - 450 VL 14 µF - 450 VL 20 µF - 450 VL	25 µF - 250 VL 25 µF - 250 VL 25 µF - 250 VL 60 µF - 300 VL		
9	ELECTRIC MOTOR	<p>2-5CRm: single-phase 220 V - 60 Hz with thermal overload protector incorporated into the winding.</p> <p>2-5CR: three-phase 220/380 V - 60 Hz or 220/440 V - 60 Hz.</p> <p>⇒ The three-phase pumps are fitted with high performance motors in class IE2 (IEC 60034-30)</p> <p>- Insulation: class F - Protection: IP X4</p>				

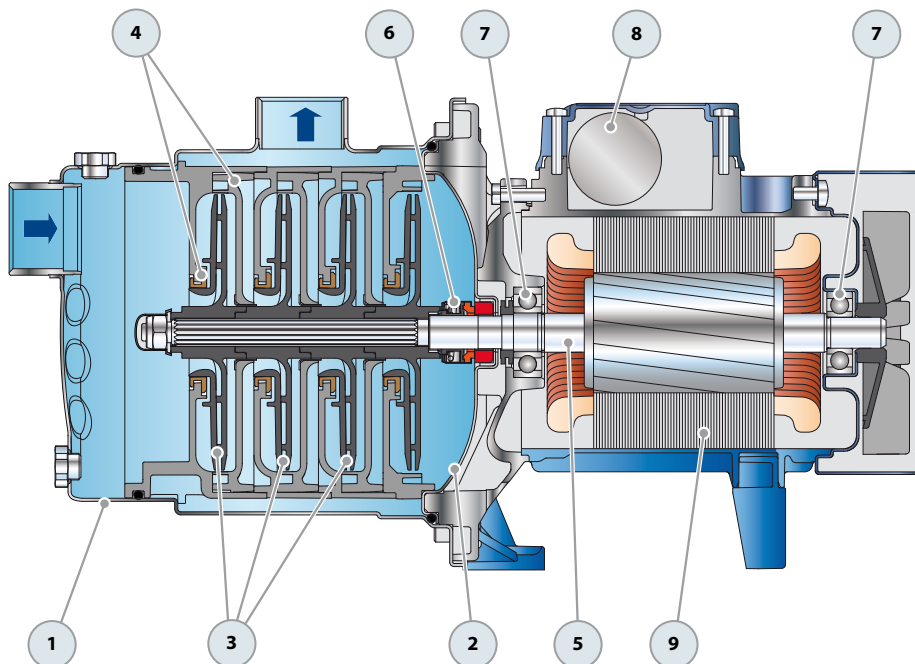

DIMENSIONS AND WEIGHT

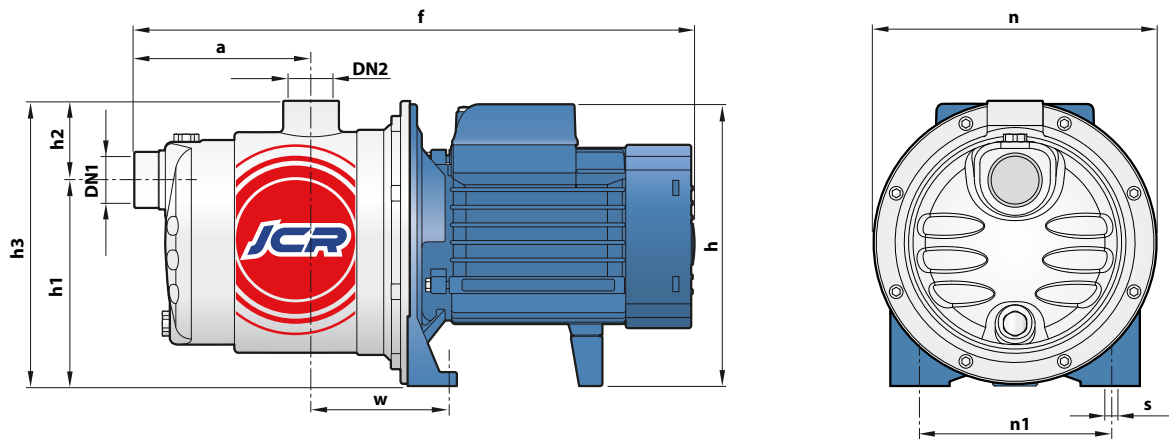

MODEL		PORTS		DIMENSIONS mm										kg	
Single-phase	Three-phase	DN1	DN2	a	f	h	h1	h2	h3	n	n1	w	s	1~	3~
2CRm 80 -N	2CR 80 -N	1"	1"	113	361	182	132	51	183	182	120	87	9	6.5	6.5
3CRm 60 -N	3CR 60 -N													6.5	6.5
3CRm 80 -N	3CR 80 -N													7.3	7.2
4CRm 80 -N	4CR 80 -N			10	8.6	7.8									
5CRm 80 -N	5CR 80 -N				10.6	10.6									
3CRm 100-N	3CR 100-N			113	9	7.1									
4CRm 100-N	4CR 100-N				10	10.2							10.2		

(*) h=221 mm for single phase versions at 110V or 127 V

ABSORPTION

MODEL	VOLTAGE		
	220 V	110 V	127 V
Single-phase	220 V	110 V	127 V
2CRm 80 -N	2.5 A	5.0 A	4.7 A
3CRm 60 -N	2.5 A	5.0 A	4.7 A
3CRm 80 -N	3.4 A	6.9 A	6.2 A
4CRm 80 -N	4.5 A	9.0 A	8.3 A
5CRm 80 -N	6.0 A	12.0 A	11.0 A
3CRm 100 -N	5.0 A	10.0 A	9.5 A
4CRm 100 -N	6.2 A	12.2 A	11.6 A

MODEL	VOLTAGE			
	220 V	380 V	220 V	440 V
Three-phase	220 V	380 V	220 V	440 V
2CR 80 -N	1.7 A	1.0 A	1.7 A	1.0 A
3CR 60 -N	1.7 A	1.0 A	1.7 A	1.0 A
3CR 80 -N	2.3 A	1.3 A	2.1 A	1.3 A
4CR 80 -N	3.0 A	1.7 A	2.6 A	1.5 A
5CR 80 -N	5.0 A	2.9 A	4.1 A	2.3 A
3CR 100 -N	3.0 A	1.7 A	2.6 A	1.5 A
4CR 100 -N	5.0 A	2.9 A	4.1 A	2.3 A

PALLETIZATION

MODEL		GROUPAGE	CONTAINER
Single-phase	Three-phase	n. pumps	n. pumps
2CRm 80 -N	2CR 80 -N	84	120
3CRm 60 -N	3CR 60 -N	84	120
3CRm 80 -N	3CR 80 -N	84	120
4CRm 80 -N	4CR 80 -N	84	120
5CRm 80 -N	5CR 80 -N	72	96
3CRm 100-N	3CR 100-N	84	120
4CRm 100-N	4CR 100-N	72	96