

Centrifugal pumps

High flow

 Clean water

 Agricultural use

 Industrial use

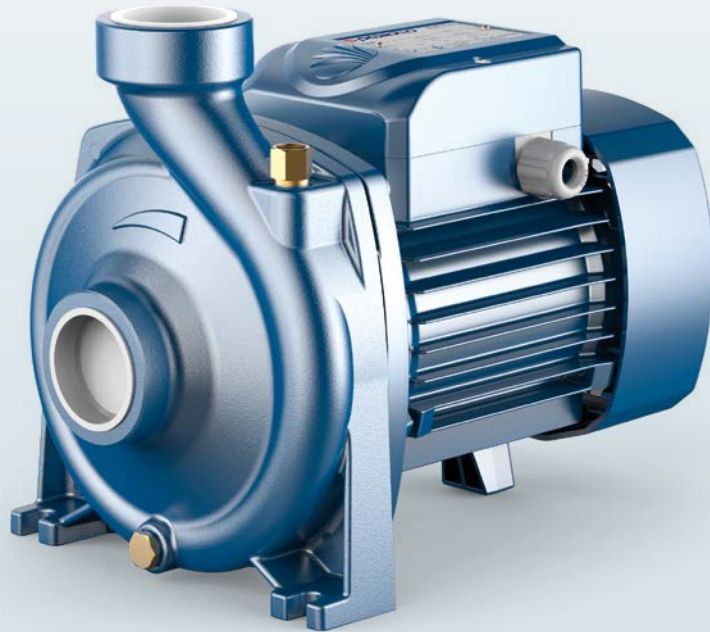

PERFORMANCE RANGE

- Flow rate up to **2200 l/min** (132 m³/h)
- Head up to **24.5 m**

APPLICATION LIMITS

- Manometric suction lift up to **7 m**
- Liquid temperature between **-10 °C** and **+90 °C**
- Ambient temperature up to **+40 °C**
- Max. working pressure:
 - **6 bar** for HF 4
 - **10 bar** for HF 6-8-20-30
- Continuous service **S1**

CONSTRUCTION AND SAFETY STANDARDS

EN 60335-1
IEC 60335-1
CEI 61-150

EN 60034-1
IEC 60034-1
CEI 2-3



CERTIFICATIONS

Company with management system certified DNV
ISO 9001: QUALITY
ISO 14001: ENVIRONMENT

INSTALLATION AND USE

Suitable for use in civil and agricultural applications. The high efficiency and continuous duty capabilities makes these pumps ideal for use in activities such as flood and spray irrigation, drawing water from lakes, rivers and wells, or for any number of different industrial applications where the characteristics of high flow rates and mid to low head are required.

The pump should be installed in an enclosed environment or sheltered from inclement weather.

OPTIONS AVAILABLE ON REQUEST

- Pump body with NPT ANSI B 1.20.1 threaded ports
- Special mechanical seal
- Other voltages

GUARANTEE

2 years subject to terms and conditions

CHARACTERISTIC CURVES AND PERFORMANCE DATA

60 Hz n= 3450 rpm HS= 0 m

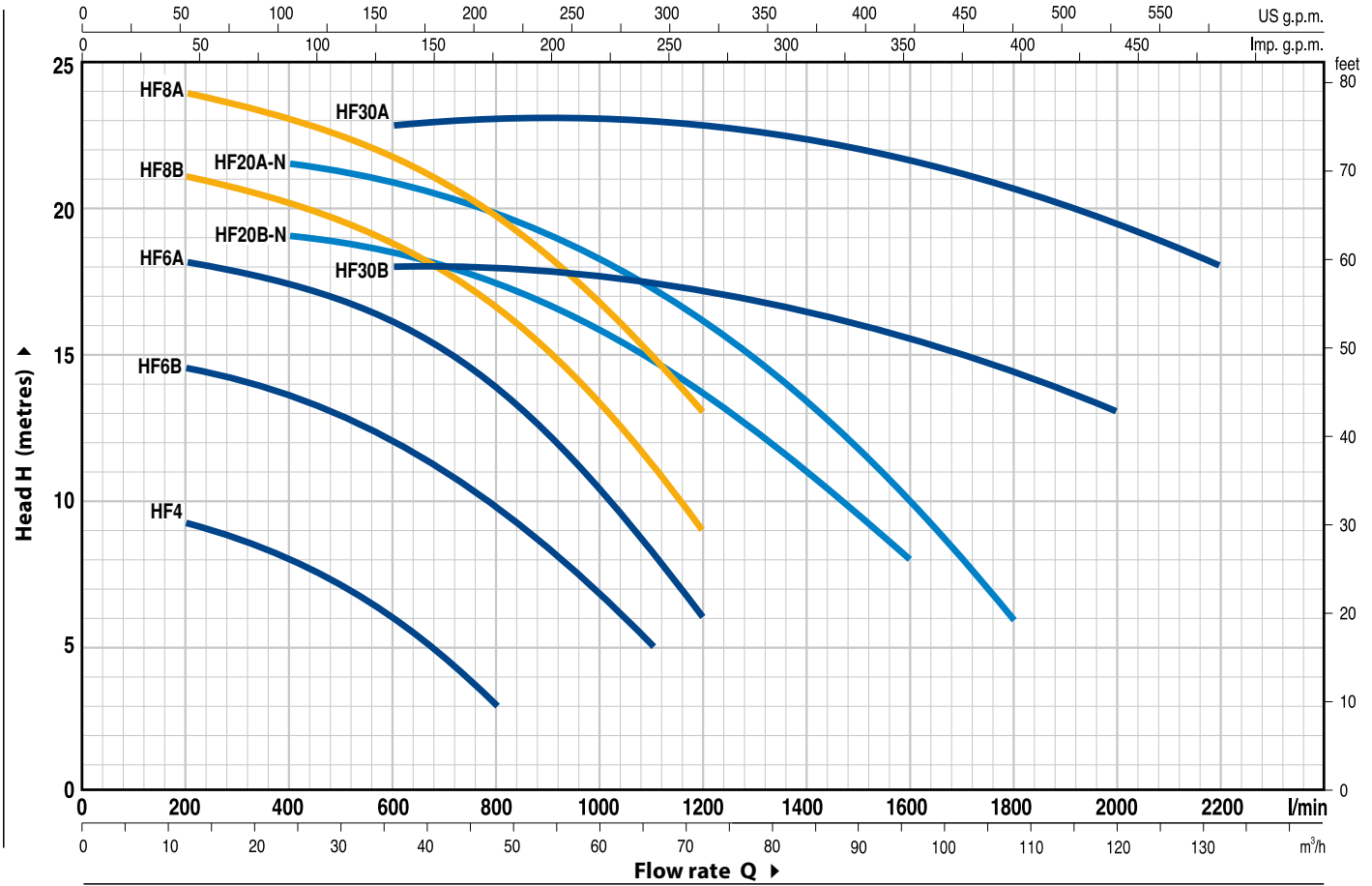

MODEL		POWER (P ₂)		▲	Q	m ³ /h																		
Single-ph.	Three-ph.	kW	HP			0	12	18	24	30	36	42	48	54	60	66	72	84	96	102	108	120	132	
					l/min	0	200	300	400	500	600	700	800	900	1000	1100	1200	1400	1600	1700	1800	2000	2200	
HFm 4	HF 4	0.75	1	IE2	H metres	10	9.3	8.7	8	7	6	4.7	3											
HFm 6B	HF 6B	1.5	2	IE3		14.7	14.5	14	13.5	12.8	12	11	9.7	8.2	6.7	5								
HFm 6A	HF 6A	2.2	3			18.5	18.1	17.8	17.2	16.8	16	15	13.8	12.2	10.5	8.3	6							
-	HF 8B	3	4	IE3		21.5	21	20.7	20	19.5	18.8	17.8	16.5	15	13.5	11.2	9							
-	HF 8A	4	5.5			24.5	24	23.5	23	22.5	21.8	20.8	19.5	18.3	16.8	15	13							
-	HF 20B-N	3	4	IE3		19	-	-	19	18.8	18.5	18	17.5	16.8	16	14.5	13.5	11	8					
-	HF 20A-N	4	5.5			21.5	-	-	21.5	21.3	21	20.5	19.8	19	18	17	16	13.3	10	8	6			
-	HF 30B	5.5	7.5	IE3		18	-	-	-	-	18	18	18	18	18	17.5	17	16.5	15.5	15	14.5	13		
-	HF 30A	7.5	10			23	-	-	-	-	23	23	23	23	23	23	22.5	22.5	22.5	22	21.5	21	19.5	18

Q = Flow rate H = Total manometric head HS = Suction height

Tolerance of characteristic curves in compliance with EN ISO 9906 Grade 3B.

▲ Performance class of the three-phase motor (IEC-60034-30)

POS. COMPONENT CONSTRUCTION CHARACTERISTICS

1 PUMP BODY	Cast iron complete with threaded ports in compliance with ISO 228/1					
2 BODY BACKPLATE	Cast iron (stainless steel AISI 304 for HF 4)					
3 IMPELLER	Brass for HF 4, HF 6, HF 8 Cast iron for HF 20, HF 30					
4 MOTOR SHAFT	Stainless steel EN 10088-3 - 1.4104					
5 MECHANICAL SEAL	<i>Pump</i>	<i>Seal</i>	<i>Shaft</i>	<i>Materials</i>		
	<i>Model</i>	<i>Model</i>	<i>Diameter</i>	<i>Stationary ring</i>	<i>Rotational ring</i>	<i>Elastomer</i>
	HF 4	AR-14	Ø 14 mm	Ceramic	Graphite	NBR
	HF 6	FN-18	Ø 18 mm	Graphite	Ceramic	NBR
	HF 8, HF 20	FN-20	Ø 20 mm	Graphite	Ceramic	NBR
	HF 30	FN-24	Ø 24 mm	Graphite	Ceramic	NBR
6 BEARINGS	<i>Pump</i>	<i>Model</i>				
	HF 4	6203 ZZ / 6203 ZZ				
	HF 6	6304 ZZ / 6204 ZZ				
	HF 8B, HF 20B-N	6206 ZZ - C3 / 6205 ZZ				
	HF 8A, HF 20A-N	6306 ZZ - C3 / 6206 ZZ - C3				
	HF 30	6307 ZZ - C3 / 6206 ZZ - C3				
7 CAPACITOR	<i>Pump</i>	<i>Capacitance</i>				
	<i>Single-phase</i>	<i>(220 V)</i>		<i>(110 V or 127 V)</i>		
	HFm 4	20 µF - 450 VL		60 µF - 300 VL		
	HFm 6B	45 µF - 450 VL		80 µF - 250 VL		
	HFm 6A	50 µF - 450 VL		-		
8 ELECTRIC MOTOR	<p>HFm: single-phase 220 V - 60 Hz with thermal overload protector incorporated into the winding.</p> <p>HF: three-phase 220/380 V - 60 Hz or 220/440 V - 60 Hz.</p> <p>➔ The three-phase pumps are fitted with high performance motors up to P₂=1.1kW in class IE2 and from P₂=1.5kW in class IE3 (IEC 60034-30)</p> <ul style="list-style-type: none"> - Insulation: class F - Protection: IP X4 					

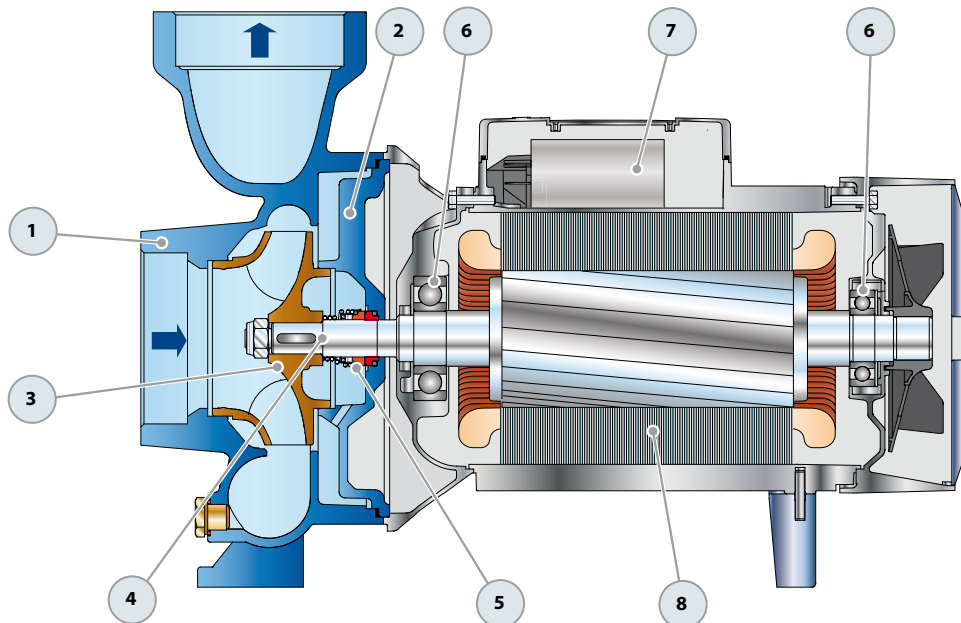

DIMENSIONS AND WEIGHT

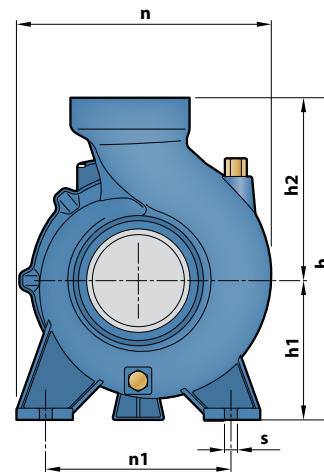
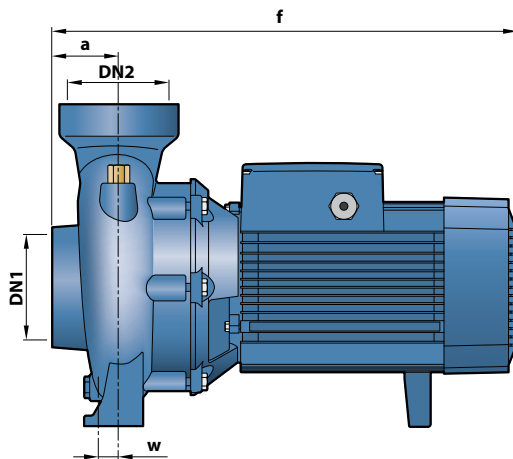

MODEL		PORTS		DIMENSIONS mm									kg	
Single-phase	Three-phase	DN1	DN2	a	f	h	h1	h2	n	n1	w	s	1~	3~
HFm 4	HF 4	2½"	2½"	47	317	240	97	143	198	155	-68	10	14.5	13.2
HFm 6B	HF 6B	3"	3"	68	411	312	120	192	240	190	6	12	26.5	25.5
HFm 6A	HF 6A				441/411								29.2	26.7
-	HF 8B	4"	4"	80	445	370	132	180	245	190	30	14	-	35.0
-	HF 8A				465								-	40.0
-	HF 20B-N				455								-	36.0
-	HF 20A-N				470								-	41.0
-	HF 30B	82	585	82	585	370	160	210	292	212			-	60.9
-	HF 30A												-	65.2

ABSORPTION

MODEL	VOLTAGE		
	220 V	110 V	127 V
Single-phase	220 V	110 V	127 V
HFm 4	6.6 A	13.2 A	12.6 A
HFm 6B	12.0 A	24.0 A	22.3 A
HFm 6A	14.5 A	-	-

MODEL	VOLTAGE			
	220 V	380 V	220 V	440 V
Three-phase	220 V	380 V	220 V	440 V
HF 4	4.5 A	2.6 A	4.2 A	2.4 A
HF 6B	8.6 A	5.0 A	7.6 A	4.2 A
HF 6A	10.7 A	6.2 A	9.0 A	4.8 A
HF 8B	12.0 A	7.0 A	13.0 A	7.0 A
HF 8A	18.2 A	10.5 A	18.5 A	12.0 A
HF 20B-N	12.0 A	7.0 A	13.0 A	7.0 A
HF 20A-N	18.2 A	10.5 A	17.8 A	11.0 A
HF 30B	22.5 A	13.0 A	20.1 A	11.8 A
HF 30A	28.8 A	16.6 A	28.0 A	16.7 A