

# Brakes

## Electromagnetically Released System

For combination with  
 DC-Micromotors:  
 2342, 2642, 2657, 3242, 3257, 3272, 3557,  
 3863, 3890  
 Brushless DC-Servomotors:  
 2444, 3056, 3564, 4490

### Series MBZ

	MBZ	12 V	22 V	24 V	
<b>Nominal coil data at 20°C</b>					
Supply voltage (DC) ±10%	$U_N$	12	22	24	Volt
Resistance	$R$	24	81	96	Ω
Current	$I$	0,50	0,27	0,25	A
Power	$P_{2\ max.}$	6	6	6	W
<b>Mechanical response times <sup>1)</sup></b>					
Coupling time		13			ms
Disconnection time		27			ms
<b>Static torque rating <sup>2)</sup></b>					
Static torque rating		400			mNm
<b>Moment of inertia</b>					
Moment of inertia		10			gcm <sup>2</sup>
<b>Max. permissible speed</b>					
Max. permissible speed		16 000			min <sup>-1</sup>
<b>Temperature range: <sup>3)</sup></b>					
Operating temperature		- 5... + 120			°C
Storage temperature		-25... + 120			°C
<b>Weight</b>					
Weight		50			g

<sup>1)</sup> Depending on the requirements, a Switch-off voltage-limitation function can be applied using an anti-parallel diode, varistor or other. However, this will influence the brake switching time.

<sup>2)</sup> Under dry operation conditions, absolutely oil-free.

<sup>3)</sup> Non condensing atmosphere.

### Features

The brakes are designed as DC operated permanentmagnet single-surface brakes characterised by the fact that the braking effect is produced by a permanentmagnetic field (electromagnetically released system). This means that the required braking force is generated when voltage is removed.

In order to neutralise the braking effect, the permanentmagnetic field is counteracted by an opposing electromagnetic field.

The brakes are intended only for use as holding brakes (unsuitable for braking rotating motor shaft).

### Full product description

Examples:  
**3242G024CR MBZ22V**

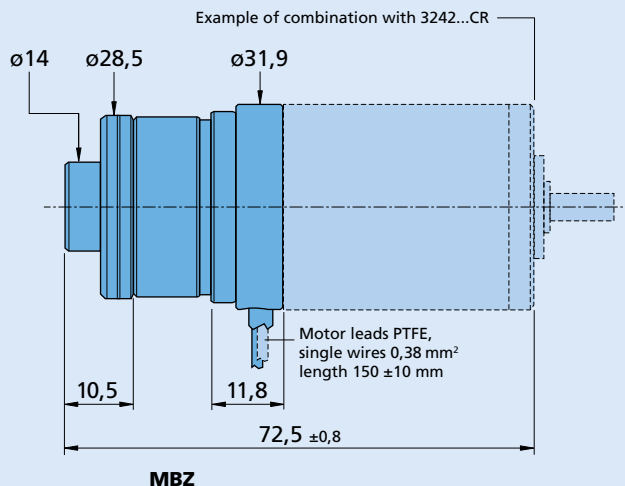

Scale reduced 