



## Alfa Laval Micro DPC

Heating and domestic hot water substation for apartments and single family houses



The Alfa Laval Micro DPC heating substation is installation-ready for complete central heating and hot water requirements. It is suitable for apartments and single family houses that are connected to a heating network. Alfa Laval has many years of experience in district heating technology, which is put to expert use in the Micro DPC, resulting in its practical function and ease of use. All components are easily accessible for inspection and future service when required.

### High comfort

Micro DPC offers fully automatic temperature control for hot water. The hot water is heated by direct exchange with high capacity. This means that the hot water is always as fresh as the incoming cold water. The room temperature is regulated with the help of thermostatic radiator valves. Integral differential pressure regulation means that good comfort is maintained throughout the year in spite of variations in the pressure of the heating network..

### Simple installation

Compact dimensions, light weight, well arranged plumbing and factory-complete internal wiring – all make installation very simple.

Micro DPC is mounted on an insulated frame and includes an insulated cover. Better insulation means less energy usage and better energy efficiency.

### Long-term security

The Micro DPC represents the most modern technology, and provides the answer to stringent demands for longterm performance. The heat exchanger plates and all piping are manufactured in acid-resistant stainless steel. All components are closely matched and carefully tested for function in accordance with Alfa Laval's quality assurance system ISO 9001:2008. Micro DPC harmonizes with PED 97/23/EC.

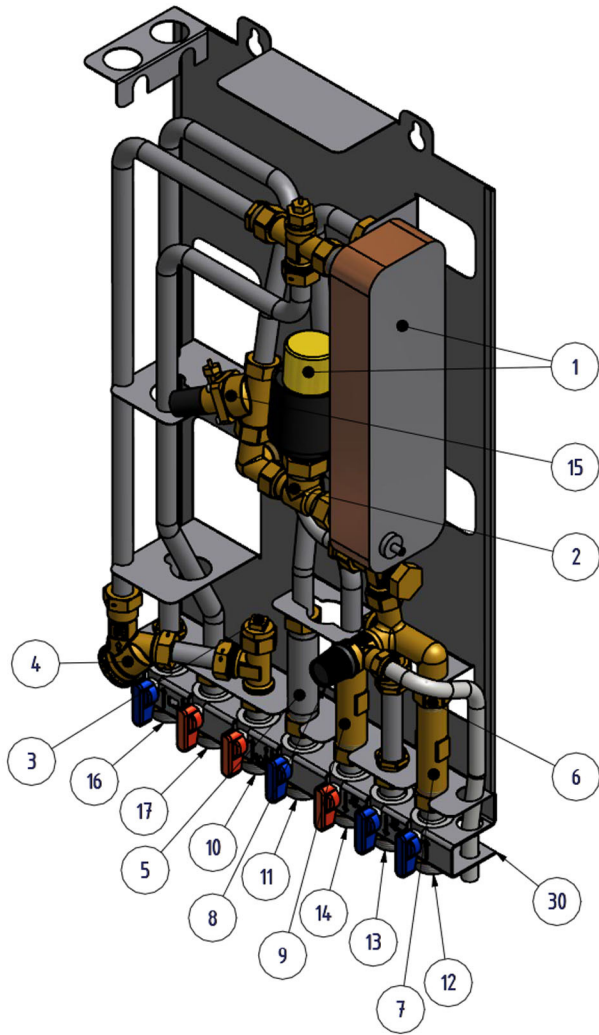

**Components**

1. Heat exchanger and temperature controller for hot water
2. Control valve for hot water
3. Temperature sensor connection, heating media supply
4. Filter for heating media
5. Adapter for energy meter
6. Check valve for cold water
7. Adapter for Cold water flow meter
8. Safety valve for domestic hot water
9. Adapter for Hot water flow meter
10. Heating network media, supply
11. Heating network media, return
12. Cold water inlet (cw)
13. Cold water outlet (cw)
14. Hot water (hw)
15. Differential pressure controller
16. Heating circuit, return
17. Heating circuit, supply
30. First fix jig including shut-off valves (option)

**Heating network – a good source of heat**

A heating network is an efficient technology that meets the need for central heating and hot water in a simple, convenient and secure way.

**Operation**

Micro DPC is used for the direct connection of apartments and single family houses to the heating network. With this kind of connection, the heating water from the heating network is used for heating the radiator system of the apartment or single family house.

A heat exchanger is used to transfer heat from the heating network medium to the hot water system. Heat is transferred through a package of thin, acid-resistant, stainless steel plates, which keeps the heating network medium separate from the domestic hot water system.

A self-sensing temperature regulator controls the hot water temperature. This measures the temperature of the hot water in the heat exchanger and automatically adjusts the outgoing flow. This patented, in-house Alfa Laval design gives a constant hot water temperature irrespective of volume and pressure flow.

The energy supplier registers use of energy. Measurement is done by recording the flow of heating network medium through the system, and by measuring the temperature difference between the medium's supply and return flow.

## Diagrammatic flow chart for Micro DPC

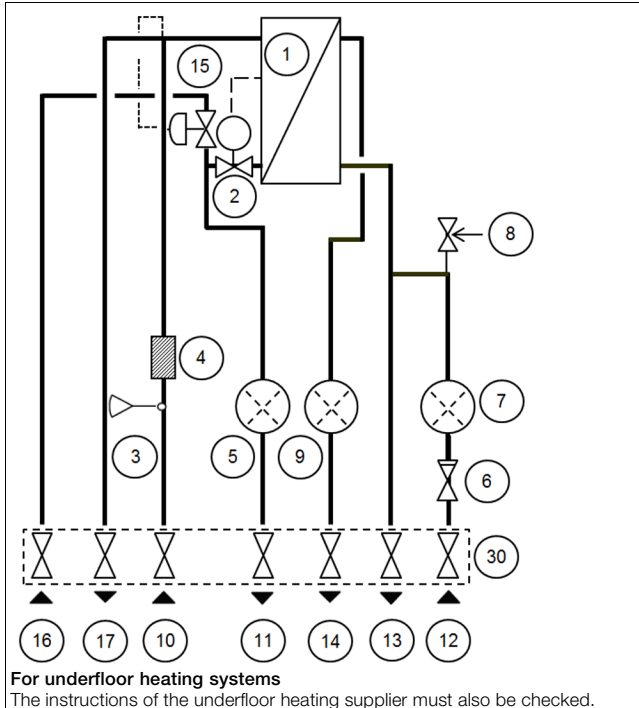

### Operating data

	Heating medium	Heating circuit	Hot water circuit
Design pressure, MPa	1.0	1.0	1.0
Design temperature, °C	100	100	100
Opening pressure, safety valve, MPa	-	-	0.9
Volume, l	0.34	-	0.36

### Performance at available differential pressure 50-400 kPa

Designed temperature programme (°C)	Capacity (kW)	Primary flow (l/s)	Actual return temp. (°C)	Secondary flow (l/s)
<b>Hot water circuit</b>				
80-25/10-55	79	0.34	25	0.42
70-25/10-58	36	0.19	25	0.18
65-25/10-50	55	0.33	25	0.33
<b>Heating circuit</b>				
80-50	10	0.08	50	0.08

## An easily manageable, economical and durable source of heat

The Micro DPC uses the heating network medium for heating the domestic hot water (providing an uninterrupted supply) as well as the water in the central heating system. The Micro DPC is a wall-mounted unit and is very compact. The unit is discreet and to minimize transmission of operational sounds, we recommend installing it on well insulated walls or on walls of concrete. Micro DPC requires no attendance or maintenance and has a very long operational life. In the event of requiring service or component exchange at some future date, all parts are easily accessible and individually replaceable.

To save time and efficiency the installation, Alfa Laval offers a first-fix- jig including shut-off valves.

### Other information

Electrical data: -----

Dimensions (cover): 430 mm width x 160 mm depth, 775 mm height

Dimensions (with out cover): 400 mm width x 120 mm depth, 630 mm height

Weight: 13 kg, cover 2 kg

Transport particulars: Total weight 20 kg, 0.08m<sup>3</sup>

### Connections first-fix jig

	Internal thread	External thread
Heating network media supply	G ¾	G 1
Heating network media return	G ¾	G 1
Heating circuit supply	G ¾	G 1
Heating circuit return	G ¾	G 1
Cold water inlet	G ¾	G 1
Cold water outlet	G ¾	G 1
Hot water	G ¾	G 1

### Option

First fix jig with shut-off valves.

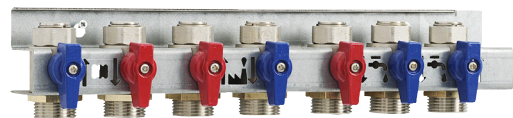

**How to contact Alfa Laval**

Up-to-date AlfaLaval contact details for all countries are always available on our website on [www.alfalaval.com](http://www.alfalaval.com)