

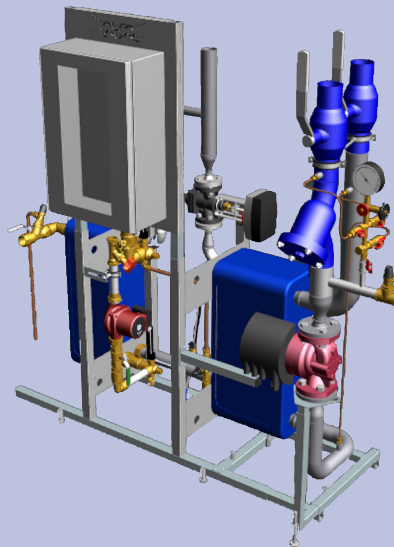

## Maxi-IQHeat

District heating substation with communication for large buildings



Maxi-IQHeat is a district heating substation for the connection of apartment blocks and other large buildings to district heating networks. IQHeat is our most advanced substation. It comes with integrated DDC and web solution.

Maxi-IQHeat reduces heating costs and flow charges for the property owner and gives lower return temperatures for network.

Maxi-IQHeat is manufactured and sold by Alfa Laval which has unique and world-leading expertise in the field of pre-fabricated district heating substations.

### **Complete and ready for operation upon delivery**

Maxi-IQHeat comes ready for operation and complete with a DDC unit and web solution according to customer specifications. The primary and secondary sides can be supplied pre-assembled.

The built-in simple Web solution can be used for easy connection to the internet. Basic software is installed and ready for operation. Communication and control takes place via the internet, ModBus or with a built-in operator panel.

### **Right dimensioning**

Each delivered Maxi IQHeat is "customised" with the components and software to exactly meet requirement specifications. IQHeat is available in several basic designs depending on the needs of the property for both heating and hot water.

### **Management, control and readings**

IQHeat can be controlled and monitored using a standard PC with an internet connection or by an operator panel. With the Web200 option, all operating information is displayed graphically on the computer screen but is also stored as Excel files for cost accounting, statistics and more..

When connecting to existing property systems, IQHeat can communicate across different protocols, see options. IQHeat always uses multiple sensors to ensure that troubleshooting and optimisation is possible remotely

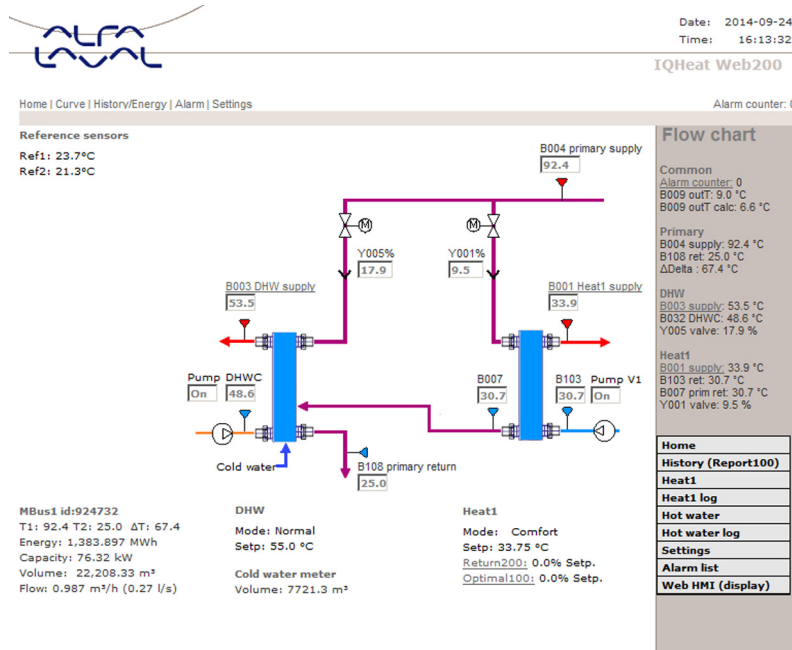

### Flow Image via IQHeat Web

In order to monitor and control one or more Maxi IQHeat district heating substations, no special equipment is required, just a standard PC with internet access.

With IQWeb200 you download a flow image from IQHeat via the Internet to your computer screen. If several substations are controlled from your computer, each substation has its own flow image. Here you get a quick overview of the district heating substation temperatures. If the values need to be adjusted, you do so on the following sides. This allows you to easily adjust, for example, for seasonal changes and to optimise operating costs.

Under the heading operation history, eight days of operation is displayed in the form of a curve chart. All operational history is continuously stored in XML files for Excel, and you can save up to 20 years of data. The operational history gives you transparent control of your adjustments and in so doing gives you both valuable feedback and statistics.

After the settings are made IQHeat automatically regulates flows and temperatures without any special supervision or control. The system has alarm functions for many parameters, such as overheating and scalding risk, operation of pumps and pressure in expansion vessels. Alarms can be sent as e-mails or SMS, see options.

### Weather forecast control, eGain forecasting™

IQHeat is prepared for direct communication with weather forecast services from eGain. With an IQHeat the communication of weather forecast for a building is done by WEB directly to eGain's servers holding data for each building. No extra hardware is needed, the IQWeb200 manage all communication.

Visit <http://egain.se/en-gb/> for more information of this unique weather forecasting, and its possibilities.



### Customised in all sizes

One of the major advantages of Maxi-IQHeat is that the substation is already tailored at the factory to meet requirement specifications. This provides optimum performance and also clear guarantee undertakings, all from a single supplier.

Maxi-IQHeat comes in basic designs for one to three heating circuits and one hot water circuit. All with integrated DDC control and ready to run default settings. All fully prepared for quick and easy installation. IQHeat 50 also comes in a version for district cooling.

### Easy to dimension correctly

The number of heating and hot water systems in your property will determine which model of Maxi-IQHeat you should choose, see table.

Model	Example of property	Heating system
IQHeat 100	Normal property, heating and hot water	One hot water One heating
IQHeat 110	Property with hot water, heating and ventilation circuits	One hot water Two heating
IQHeat 120	Property with hot water and three heating circuits	One hot water Three heating
IQHeat 50	Property with only one heating circuit	One heating
IQHeat 60	Larger premises, need of two separate heating circuits	Two heating

Operation cards are available for each model.

Please contact Alfa Laval if you are interested of a quote or more information.

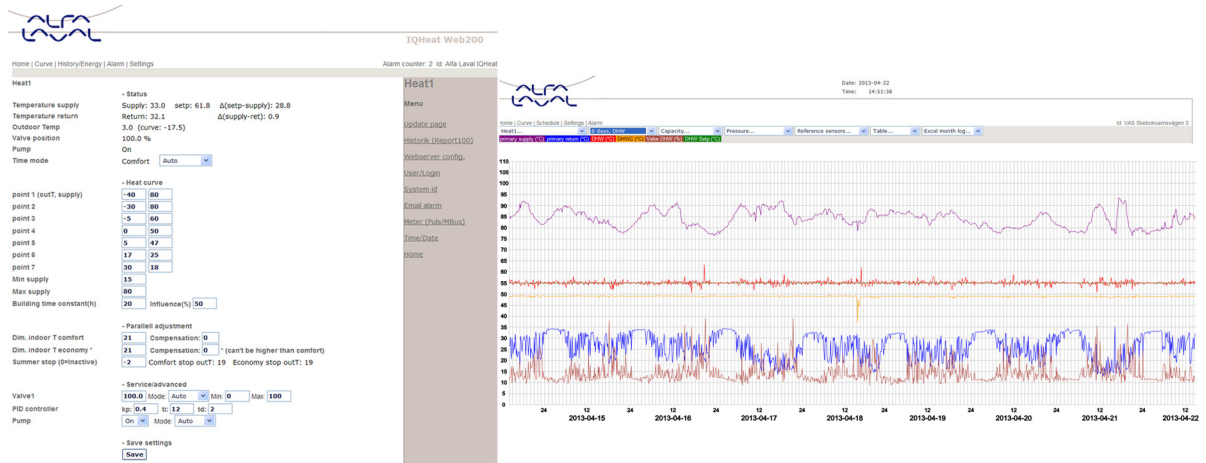

Heating settings and history via IQHeat Web

### Basic version

An operator panel is included as standard, along with communications with ModBus, a simple Web solution with the same information as the operator panel.

### Monitoring with choice

IQHeat comes with optional communications solution. Changeable also after installation by replacement or adding of communication modules.

- IQHeat Web200, web solution and a PC with Internet access is an effective solution for controlling and managing one or more Maxi IQHeat units. Complete with flow images.
- IQHeat, connection to existing property system. If a property system is already in place with familiar functions and interfaces, IQHeat communicates via OPC, Modbus, LON or BacNet. This means that the plant is controlled locally by IQHeat during the construction period. When the external, master system is then connected, IQHeat will be controlled by the sent parameters. Flow images must be created in the master system.
- IQMeter200 provides the option of reading the heat meter values via Mbus. The functions such as capacity control in Web200 can then be activated to optimise operating costs.

### Options

- IQAlarm. SMS alerts via Modem
- IQRefill. Upgrading an existing substation to the IQHeat standard

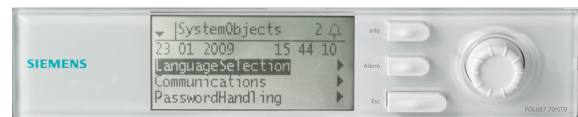

Alfa Laval continuously works on improving existing functions in IQHeat, as well as developing new.

New versions of IQHeat applications can be downloaded through internet, for units that need update, or upgrading.

**How to contact Alfa Laval**

Up-to-date AlfaLaval contact details for all countries are always available on our website on [www.alfalaval.com](http://www.alfalaval.com)