



AlfaBlue BDM / BDMY / BDD / BDD6 / BDDY

Dry coolers

General information & application

The AlfaBlue series is a wide range of heavy-duty dry coolers. Dry coolers are often used for cooling down condenser water in air conditioning and refrigeration installations. In the processing industry, dry coolers are suitable for closed circuit cooling of various process liquids. With a wide range of sound pressure level alternatives, these units are particularly suited to demanding, noise sensitive environments. AlfaBlue dry coolers are available for both horizontal and vertical air direction, either in single (M) or dual (D) coil execution.

Capacities * 16 up to 1028 kW

* water, EN1048.

Coil

An innovative coil design provides excellent heat transfer. In standard execution dry coolers are fitted with smooth copper tubing (1/2", 3/8" or 5/8") or stainless steel tubing (5/8"). Fins in aluminium or sea water resistant AlMg2.5, available in two fin designs:

Turbo fins	maximized capacity
Industrial power fins (IF)	long lasting performance

Available in different fin thicknesses and fin spacings. Coil configuration optimized according to liquid flow. Separate connections in the D series provide the opportunity for independent operation of both coils.

Casing

Frame construction provides high rigidity for protection against vibration and thermal expansion. Casing and framework of corrosion resistant pre-galvanized sheet steel (high corrosion resistance), epoxy coated white RAL 9002 on both sides. Separated fan sections.

Fan motors

Available in four fan diameters (630, 800, 910 & 1000 mm) and five noise levels, power supply 400/50/3. Motors with external rotor, protection class IP 54 according to DIN 40050. Integrated thermo contacts provide reliable protection against thermal overload. EC fan motors available.

Options

- Spray water device (D series only)
- Vibration dampers (VD)
- Special fan motors 400V/60Hz



AlfaBlue BDD

- Coil corrosion protection
 - Fins epoxy coated (EP)
 - Fins seawater resistant aluminium alloy 57S/5052 (SWR)
 - Copper fins
 - Blygold treatment (BY)
 - F-coat treatment (FC)
- Electrical options
 - Safety switch (SW)
 - Motors wired to a common terminal box (CB)
 - Switchboard basic IP55 (B)
 - EMC approved components
 - Fan step control (BP/BSP), Fan speed control (BFP/BSFP) or Frequency control (BI/BIC)

Customisation (on request)

- Multi-circuiting
- Special fan motors
 - 480/3/60 (IP54)
 - Protection class IP55
 - High-temperature motors

Certifications

All dry cooler models are "Eurovent Certify All" certified. The Alfa Laval quality system is in accordance with ISO 9001. All products are manufactured according to CE and PED rules.

Design pressure

Design pressure 6 bar. Each heat exchanger is leak tested with dry air.

Selection

Selection and pricing is to be performed with our Alfa Laval air heat exchanger selection software. Please contact our sales organization for details and full technical documentation.

Dimensions mm (indicative)

type	L1*	L2*	W	H
BDM 631	1545	1625	1214	1221
BDM 632	2635	2715	1214	1221
BDM 633	3725	3805	1214	1221
BDM 634	4815	4895	1214	1221
BDML 631	1855	1935	1214	1221
BDML 632	3255	3335	1214	1221
BDML 633	4655	4735	1214	1221
BDM 801	2205	2285	1454	1252
BDM 802	3955	4035	1454	1252
BDM 803	5705	5785	1454	1252
BDM 804	7455	7535	1454	1252
BDM 805	9205	9285	1454	1252
BDM 901	2555	2635	1454	1289
BDM 902	4655	4735	1454	1289
BDM 903	6755	6835	1454	1289
BDM 904	8855	8935	1454	1289
BDM 1001	2555	2635	1454	1295
BDM 1002	4655	4735	1454	1295
BDM 1003	6755	6835	1454	1295
BDM 1004	8855	8935	1454	1295
BDD 802	3955	4035	2249	1252
BDD 803	5705	5785	2249	1252
BDD 804	7455	7535	2249	1252
BDD 805	9205	9285	2249	1252
BDD 806	10955	11035	2249	1252
BDD 902	4655	4735	2249	1289
BDD 903	6755	6835	2249	1289
BDD 904	8855	8935	2249	1289
BDD 905	10955	11035	2249	1289
BDD 1002	4655	4735	2249	1278
BDD 1003	6755	6835	2249	1278
BDD 1004	8855	8935	2249	1278
BDD 1005	10955	11035	2249	1278

*L1 = BDM/BDD/BDD6, L2 = BDMY/BDDY

Dimensions BDM

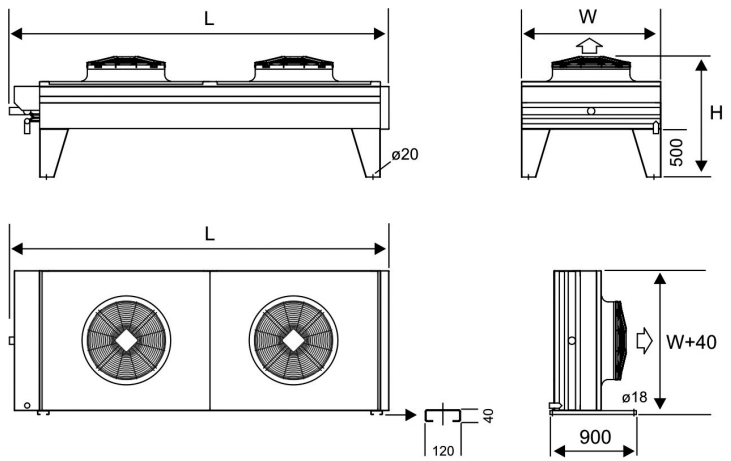

Dimensions BDD

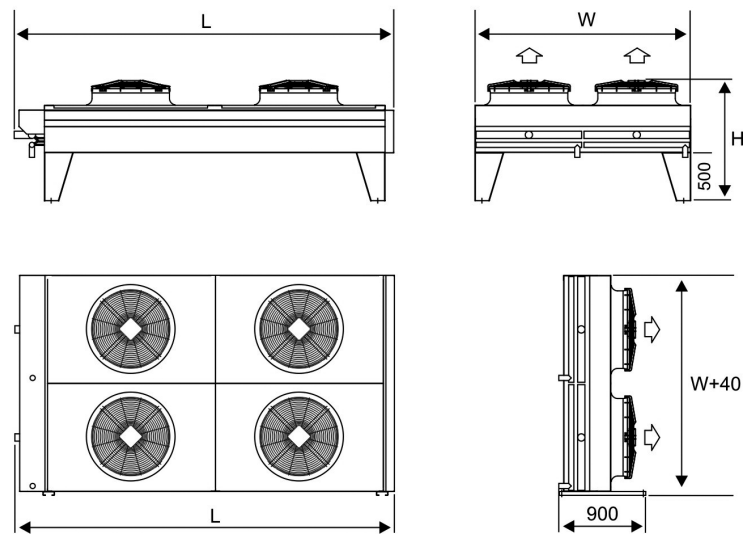

Code description

BDM S(E)			80 5		B D CR *				- AL 2.1 CU *				
1	2	3	4	5	6	7	8	9	10	11	12	13	

- 1 AlfaBlue dry cooler (BDM/BDD = standard Cu tubes, BDD6 = 5/8" Cu tubes, BDMY/BDDY = SS304 tubes)
- 2 Number of separated coils (M=1, D=2)
- 3 Sound level/fan code (T=high performance, S-standard, L=low, Q=quiet, R=residential, E=EC fan motor)
- 4 Fan diameter (63=630, 80=800 mm, 90=910, 100=1000 mm)
- 5 Number of fans per coil (BDM = 1 to 5, BDD = 2 to 6)
- 6 No. of tube rows (A=2, B=3, C=4)
- 7 Fan motor connection (D=delta, Y=star)
- 8 Packing (CR=crate) / mounting feet (Feet)
- 9 Electrical options
- 10 Fin material/coating (AL=aluminium, IF=industrial fins, SWR=AlMg2.5, EP=epoxy coated alu, FC=F-coat, BY=Blygold)
- 11 Fin spacing (2.1, 2.3, 2.5, 3.0 and 3.2 mm)
- 12 Tube material (CU=copper)
- 13 Options

Benefits

- Heavy duty design with high corrosion resistance
- Reduced liquid charge
- Available with easily cleanable industrial power fins
- Excellent sound characteristics
- Reliable performance, Eurovent certified
- Easy installation & maintenance.
- Energy efficient - low total cost of ownership.
- Two-year product guarantee.
- Easy access to additional on-line product information (QR code)



How to contact Alfa Laval

Up-to-date Alfa Laval contact details for all countries are always available on our website at www.alfalaval.com

