



AlfaBlue BCM/BCD & BNM/BND

Air-cooled condensers

General information & application

The AlfaBlue series is a wide range of heavy-duty air cooled condensers for air conditioning and refrigeration applications. AlfaBlue condensers are available for both horizontal and vertical air direction, either in single (M) or dual (D) coil execution.

Refrigerants	all halocarbon (BC) or ammonia (BN)
Capacities H(C)FC*	15 up to 862 kW
Capacities ammonia*	20 up to 1200 kW

* Nominal capacities ($T_{air} = 25^{\circ}\text{C}$, $T_{cond} = 40^{\circ}\text{C}$, $T_{subcool} < 3\text{K}$, $T_{superheating} = 25\text{K}$).

Coil

An innovative coil design provides excellent heat transfer at minimal refrigerant charge. Depending on the application, condensers are fitted with cross-fin copper or smooth stainless steel tubing. Available with two Alu-fin types:

Turbo fins	maximized capacity
Industrial power fins (IF)	long lasting performance

Available in different fin thicknesses and fin spacings. Separate connections in the D series provide the opportunity for independent operation of both condenser coils.

Casing

Frame construction provides high rigidity for protection against vibration and thermal expansion. Casing and framework of corrosion resistant pre-galvanized sheet steel (corrosion resistance class C4), epoxy coated white RAL 9002 on both sides. Separated fan sections.

Fan motors

High efficiency AC or EC fan motors, available in four fan diameters (630, 800, 910 & 1000 mm) and five noise levels, power supply 400/50/3. Motors with external rotor, protection class IP 54 according to DIN 40050. Integrated thermo contacts provide reliable protection against thermal overload.

Options

- Sub-cooling circuit (SC)
- Coil corrosion protection
 - Fins epoxy coated (EP)
 - Fins seawater resistant aluminium alloy 57S/5052 (SWR)
 - Blygold treatment (BY)
 - F-coat treatment (FC)



AlfaBlue condensers

- Spray water device (KW, D series only)
- Vibration dampers (VD)
- Electrical options
 - Safety switch (SW)
 - Motors wired to a common terminal box (CB)
 - Switchboard basic IP55 (B)
 - EMC approved components
 - Fan step control (BP/BSP)
 - Fan speed control (BFP/BSFP)
 - Frequency control (BI/BIC)

Customisation (on request)

- Multi-circuiting
 - 480/2/60 (IP54)
 - Protection class IP55
 - High-temperature motors

Certifications

BCM/BCD Models are "Eurovent Certify All" certified. The Alfa Laval quality system is in accordance with ISO 9001. All products are manufactured according to CE and PED rules.

Design pressure

Design pressure 33 bar (BCM/BCD) or 27 bar (BNM/BND). Each heat exchanger is leak tested with dry air and finally supplied with a nitrogen pre-charge.

Selection

Selection and pricing is to be performed with our Alfa Laval air heat exchanger selection software. Please contact our sales organization for details and full technical documentation.

Dimensions

type	L	W	
B*M 631	1545	1214	1221
B*M 632	2635	1214	1221
B*M 633	3725	1214	1221
B*M 634	4815	1214	1221
B*ML 631	1855	1214	1221
B*ML 632	3255	1214	1221
B*ML 633	4655	1214	1221
B*M 801	2205	1454	1252
B*M 802	3955	1454	1252
B*M 803	5705	1454	1252
B*M 804	7455	1454	1252
B*M 805	9205	1454	1252
B*M 901	2555	1454	1289
B*M 902	4655	1454	1289
B*M 903	6755	1454	1289
B*M 904	8855	1454	1289
B*M 1001	2555	1454	1295
B*M 1002	4655	1454	1295
B*M 1003	6755	1454	1295
B*M 1004	8855	1454	1295
B*D 802	3955	2249	1252
B*D 803	5705	2249	1252
B*D 804	7455	2249	1252
B*D 805	9205	2249	1252
B*D 806	10955	2249	1252
B*D 902	4655	2249	1289
B*D 903	6755	2249	1289
B*D 904	8855	2249	1289
B*D 905	10955	2249	1289
B*D 1002	4655	2249	1278
B*D 1003	6755	2249	1278
B*D 1004	8855	2249	1278
B*D 1005	10955	2249	1278

Dimensions B*M

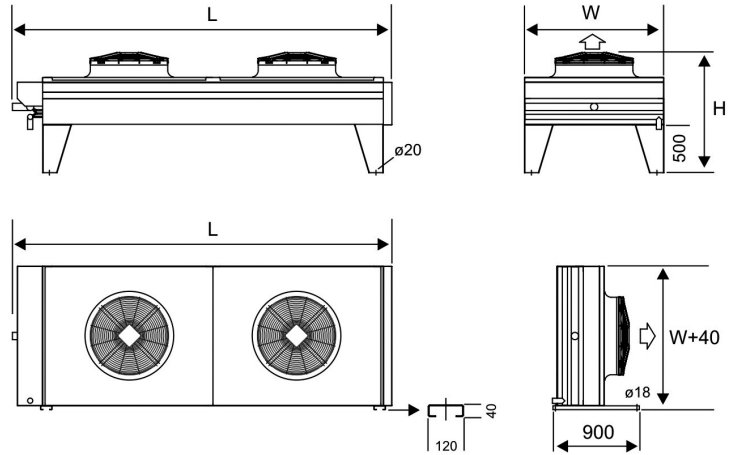

Dimensions B*D

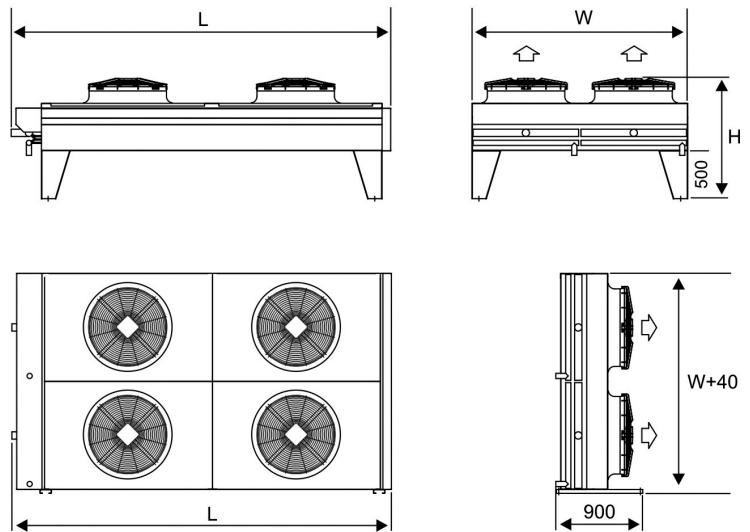

Code description

B	C	M	S(E)	63	2	L	A	D	CR	*	-	AL	2.1	CU	*
1	2	3	4	5	6	7	8	9	10	11		12	13	14	15

- AlfaBlue condenser
- Refrigerant (C=H(C)FC, N=ammonia)
- Number fan rows (M=1, D=2)
- Sound level/fan code (T=turbo, S-standard, L=low, Q=quiet, R=residential, E=EC fan motor)
- Fan diameter (63=630, 80=800 mm, 90=910, 100=1000 mm)
- Number of fans per row (B*M = 1 to 5, B*D = 2 to 6)
- Module length (optional: L=long)
- Tube rows code (A, B, C)
- Fan motor connection (D=delta, Y=star)
- Packing (CR=crate) / mounting feet (Feet)
- Electrical options
- Fin material/coating (AL=aluminium, IF=industrial fins, SWR=AlMg2.5, EP=epoxy coated alu, FC=F-coat, BY=Blygold)
- Fin spacing (2.1, 2.3, 2.5, 3.0 and 3.2 mm)
- Tube material (CU=copper, SS=stainless steel)
- Options

Benefits

- Heavy duty design with high corrosion resistance
- Reduced refrigerant charge
- Available with easily cleanable industrial power fins
- Excellent sound characteristics, suitable for residential applications
- Reliable performance, Eurovent certified
- Easy installation & maintenance.
- Energy efficient - low total cost of ownership.
- Two-year product guarantee.
- Easy access to additional on-line product information (QR code)



How to contact Alfa Laval

Up-to-date Alfa Laval contact details for all countries are always available on our website at www.alfalaval.com

