

Profile

- Robust handwheel made of aluminum casting
- Rounded design with dirt corners minimized
- Various sizes
- Plastic-coated or bright-finished surface
- Various hub versions
- Turning handle as an option (see accessories)

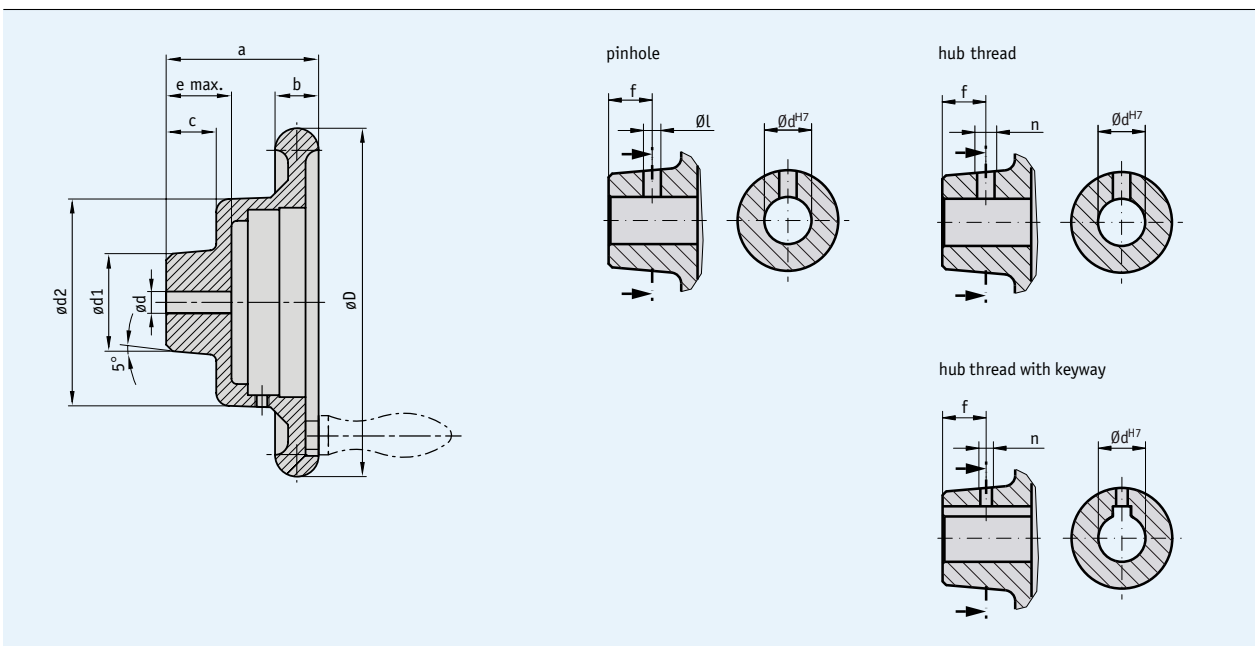

1.4

Mechanical data

■ Dimensions

type	ØD	Ødv	Ødx	Ød1	Ød2	a	b	c	e	GfG	suitable for	weight	material
HS 8	80	5.8	16	26	60	55	15	18	20	M6	S50/1	0.2 kg	aluminum
HS 12	125	6.8	25	40	95	70	16.5	23	30	M6	S80/1; SZ80/1	0.5 kg	aluminum
HS 14	140	6.8	20	32	95	70	18	23	29	M8	S80/1; SZ80/1	0.6 kg	aluminum
HS 16	160	7.8	30	45	95	70	20	23	30	M8	S80/1; SZ80/1	0.7 kg	aluminum
HS 18	180	7.8	30	45	95	75	22	28	34	M10	S80/1; SZ80/1	0.8 kg	aluminum
HSL 20	200	7.8	35	55	134	75	22	28	34	M10	S120/1	0.9 kg	aluminum

dv = d predrilled; dx = d max.; GfG = thread for handle

■ **Special versions**

Handwheel type		HS 8					
Bore dH7		6 ... 8	9, 10	11, 12	13, 14	15	16
Groove width for keyway JS9			3	4	5		
Pinhole		3.8/12	3.8/12	3.8/12	4.8/12	4.8/12	4.8/12
Hub thread	without keyway JS9	M4/12	M4/12	M4/12	M6/12	M6/12	M6/12
	with keyway JS9		M3/12	M3/12			

*) not for HS 8

Handwheel type		HS 12 / HS 14							
Bore dH7		7, 8	9, 10	11, 12	13 ... 17	18 ... 20	21**)	22**)	23 ... 25**)
Groove width for keyway JS9			3	4	5	6**)	6**)	6**)	
Pinhole		3.8/12	3.8/12	3.8/12	4.8/12	4.8/12	4.8/12**)	4.8/12**)	4.8/12**)
Hub thread	without keyway JS9	M4/12	M4/12	M4/12	M6/12	M6/12	M6/12**)	M6/12**)	M6/12**)
	with keyway JS9		M3/12	M3/12	M4/12	M5/12**)	M5/12**)		

**)) not for HS14

Handwheel type		HS 16 / HS 18							
Bore dH7		8	9, 10	11, 12	13 ... 17	18 ... 22	23 ... 25	26, 27	28 ... 30
Groove width for keyway JS9			3	4	5	6	8	8	
Pinhole		3.8/12	3.8/12	3.8/12	4.8/12	4.8/12	4.8/12	5.8/12	5.8/12
Hub thread	without keyway JS9	M4/12	M4/12	M4/12	M6/12	M6/12	M6/12	M8/12	M8/12
	with keyway JS9		M3/12	M3/12	M4/12	M5/12			

Handwheel type		HSL 20								
Bore dH7		8	9, 10	11, 12	13 ... 17	18 ... 22	23 ... 25	26, 27	28 ... 30	31 ... 35
Groove width for keyway JS9			3	4	5	6	8	8	8	10
Pinhole		3.8/12	3.8/12	3.8/12	4.8/12	4.8/12	4.8/12	5.8/12	5.8/12	5.8/12
Hub thread	without keyway JS9	M4/12	M4/12	M4/12	M6/12	M6/12	M6/12	M8/12	M8/12	M8/12
	with keyway JS9		M3/12	M3/12	M4/12	M5/12	M6/12	M6/12	M6/12	

Order

Order table

Feature	Order data	Technical data	Additional information
Handwheel type	HS...	8, 12, 14, 16, 18	see "Dimensions"
	HSL...	20	
Surface	B	unvarnished	
	C	plastic-coated, hammer finish paint light-gray	
		others on request	
Handle bore	OG	without handle bore	see "Dimensions", value GfG
	...	M6 ... M10 with handle bore or handle thread	
Bore Ød	d vorg.	predrilled	see "Dimensions", value Ødv
	...	6 ... 35 d max. in mm steps (H7)	see "Dimensions"
Keyway	OP	without keyway	
	JS9	light seat	
	P9	tight seat	
Pinhole (only without keyway)	OS	without pinhole	see table "Special versions", depending on handwheel type, only if hub thread "ONG"
	...	diameter "Ø"/measure "F" (e.g., 3.8/12)	
		others on request	
Hub thread	ONG	without hub thread	see table "Special versions", depending on handwheel type, only if pinhole "OS"
	...	thread "n"/measure "f" (e.g., M4/12)	
		others on request	
Hub turned down	OAN	without turned-down hub	
		others on request	
Position indicator mounted (*)	PM	position indicator mounted	
	PS	separate position indicator	

* separate order of a position indicator required (see pages 74-82)

Order code



Scope of delivery: HS.../HSL...

Accessories:

Handles
End plate

Page 102
Page 103

Additional information:

General information and areas of application

Page 68 cont.