

Profile

- Low-cost and compact turning handle made of glass-fiber reinforced plastic
- Various sizes
- Surface with rounded edges avoids accumulation of dirt
- Hub made of plastic or metal
- Various hub versions

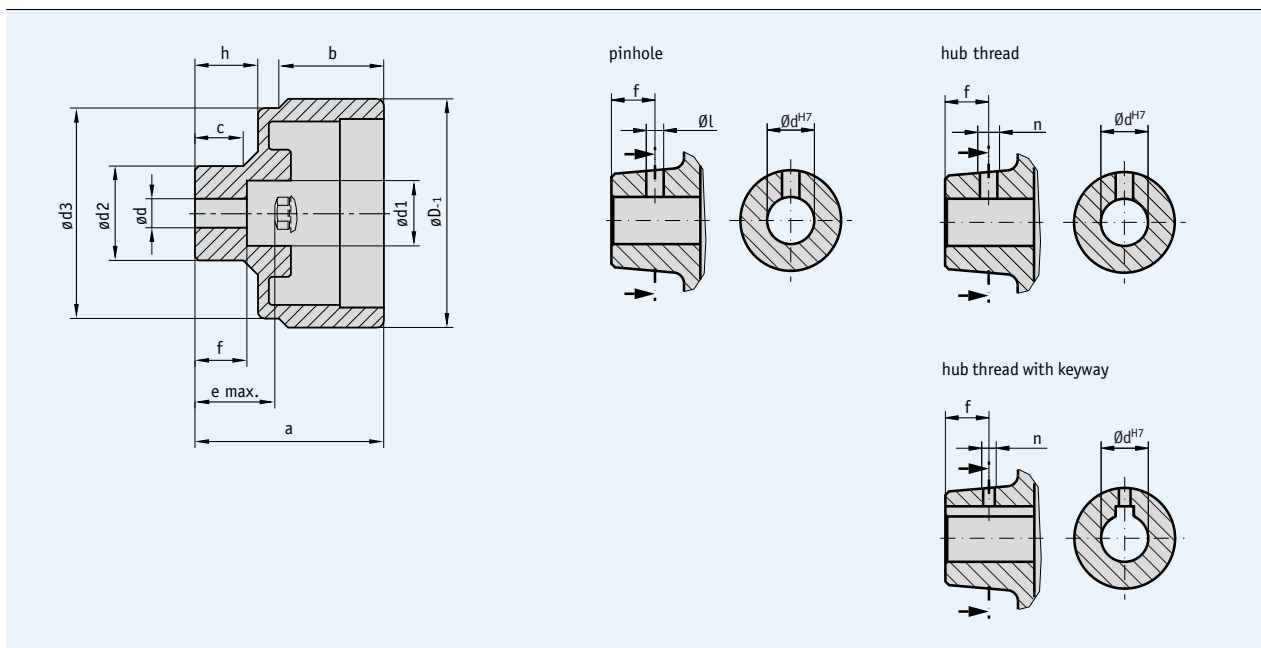

Mechanical data

■ Dimensions

type	Hub	$\varnothing D$	$\varnothing dv$	$\varnothing dx$	$\varnothing d_1$	$\varnothing d_2$	$\varnothing d_3$	a	b	c	e	f	h	suitable for	weight	material
HG 5	plastic	63		6 ... 12 ^{H9}	13	21	58	49	28.9	14.3	19.2	17.3	14.3	S50/1	0.1 kg	plastic
	metal	63	5.8	6 ... 16 ^{H7}	18	26	58	52	28.9	13.3	22.2	14.3	17.3	S50/1	0.1 kg	plastic
HG 10	plastic	98		6 ... 16 ^{H9}	16	30	93	56	31.5	18.7	22.8	20.7	18.7	S80/1; SZ80/1	0.2 kg	plastic
	metal	98	5.8	6 ... 16 ^{H7}	25.5	35	93	59	31.5	18.2	25.8	18	21.7	S80/1; SZ80/1	0.2 kg	plastic

dv = d predrilled

■ Special versions

Handwheel type	HG 5				HG 10				
Plastic hub	•	•	•	•	•	•	•	•	
Metal hub	•	•	•	•	•	•	•	•	
Bore dH7	6, 8	9, 10	12	14*	6 ... 8	9, 10	11, 12	13 ... 16	
Groove width for keyway JS9		3	4	5		3	4	5	
Pinhole	3.8/10	3.8/10	3.8/10	4.8/10*	3.8/10	3.8/10	3.8/10	4.8/10	
Hub thread	without keyway JS9	M4/10	M4/10	M4/10*	M6/10*	M4/10	M4/10	M4/10	M6/10
	with keyway JS9	M3/10	M3/10	M3/10		M3/10	M3/10	M4/10	

*) not possible with plastic hub, special versions available on request. Note: Characters highlighted in orange are order features.

Order

Order table

Feature	Order data	Technical data	Additional information
Handwheel type	HG... A	5, 10	see "Dimensions"
Hub material	A	aluminum	
	K	plastic reinforced	
	VA	Nirosta	
Bore Ød	d vorg.	predrilled	see "Dimensions", value Ødv
	...	6 ... 16 d max. in mm steps (H7)	see "Dimensions"
Keyway	OP	without keyway	
	JS9	light seat	according to DIN 6885 T1, only with hub material VA + A
	P9	tight seat	according to DIN 6885 T1, only with hub material VA + A
Pinhole (only without keyway)	OS	without pinhole	
	...	diameter "Ø"/measure "f" (e.g., 3.8/10)	see table "Special versions", depending on handwheel type, only if hub thread "ONG"
		others on request	
Hub thread	ONG	without hub thread	
	...	thread "n"/measure "f" (e.g., M4/12)	see table "Special versions", depending on handwheel type, only if pinhole "OS", only with hub material VA + A
		others on request	
Hub turned down	OAN	without turned-down hub	
		others on request	
Position indicator mounted (*)	PM	position indicator mounted	
	PS	separate position indicator	

* separate order of a position indicator required (see pages 74-82)

Order code

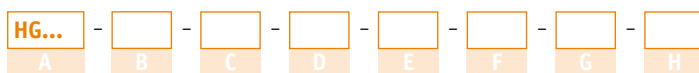

Scope of delivery: HG...

Accessories:

End plate

Page 103

Additional information:

General information and areas of application

Page 68 cont.