

Handwheel HK.../HKL...

Aluminum handwheel in popular design

Profile

- Classical handwheel made of aluminum casting
- Various sizes
- Plastic-coated or bright-finished surface
- Various hub versions
- Turning handle as an option (see accessories)

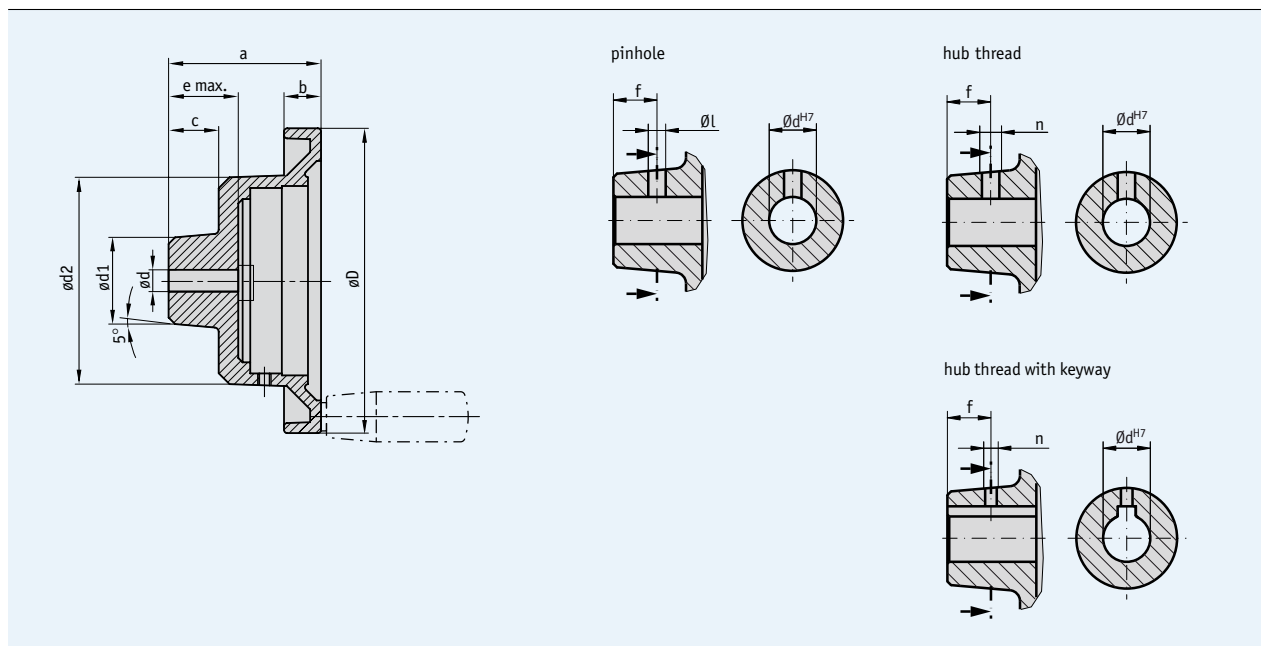

Mechanical data

■ Dimensions

type	ØD	Ødv	Ødx	Ød1	Ød2	a	b	c	e	GfG	suitable for	weight	material
HK 8	80	5.8	16	26	60	52	14	20	21	M6	S50/1	0.2 kg	aluminum
HK 12	120	6.8	25	40	95	64	15	23	30	M6	S80/1; SZ80/1	0.5 kg	aluminum
HK 14	140	6.8	25	40	95	70	17	23	30	M8	S80/1; SZ80/1	0.6 kg	aluminum
HK 16	160	7.8	25	40	95	70	20	23	28	M8	S80/1; SZ80/1	0.7 kg	aluminum
HK 20	200	7.8	30	45	95	75	22	25	32	M10	S80/1; SZ80/1	0.8 kg	aluminum
HKL 20	200	7.8	30	45	132	75	22	25	30	M10	S120/1	0.9 kg	aluminum

dv = d predrilled; dx = d max.; GfG = thread for handle

Special versions

Handwheel type	HK 8			
Bore dH7	6 ... 8	9, 10	11, 12	13 ... 16
Groove width for keyway JS9		3	4	5
Pinhole	3.8/12	3.8/12	3.8/12	4.8/12
Hub thread	without keyway JS9	M4/12	M4/12	M6/12
	with keyway JS9	M3/12	M3/12	

Handwheel type	HK 12 / HK 14 / HK 16						
Bore dH7	7*), 8	9, 10	11, 12	13 ... 17	18 ... 21	22	23 ... 25
Groove width for keyway JS9		3	4	5	6	6	8
Pinhole	3.8/12	3.8/12	3.8/12	4.8/12	4.8/12	4.8/12	4.8/12
Hub thread	without keyway JS9	M4/12	M4/12	M4/12	M6/12	M6/12	M6/12
	with keyway JS9	M3/12	M3/12	M4/12	M5/12		

*) Bore Ø7H7 only for HK 12 / HK 14

Handwheel type	HK 20 / HKL 20							
Bore dH7	8	9, 10	11, 12	13 ... 17	18 ... 22	23 ... 25	26	27 ... 30
Groove width for keyway JS9		3	4	5	6	8	8	8**)
Pinhole	3.8/12	3.8/12	3.8/12	4.8/12	4.8/12	4.8/12	5.8/12	5.8/12
Hub thread	without keyway JS9	M4/12	M4/12	M4/12	M6/12	M6/12	M8/12	M8/12
	with keyway JS9	M3/12	M3/12	M4/12	M5/12			

***) not for HKL 20, additional special versions available on request. **Note: Characters highlighted in orange are order features.**

Order

Order table

Feature	Order data	Technical data	Additional information	
Handwheel type	HK...	8, 12, 14, 16, 20	see "Dimensions"	
	HKL20		see "Dimensions"	
Surface	B	unvarnished		
	C		plastic-coated, hammer finish paint, light-gray	
			others on request	
Handle bore	OG	without handle bore		
	...	M6, M8, M10 with handle bore or handle thread	see "Dimensions", value GfG	
Bore Ød	d vorg.	predrilled, see table above, value Ødv		
	...	6 ... 30 d max. in mm steps (H7)	see "Dimensions"	
Keyway	OP	without keyway		
	JS9	light seat	according to DIN 6885 T1	
	P9	tight seat	according to DIN 6885 T1	
Pinhole (only without keyway)	OS	without pinhole		
	...	diameter "Øl"/measure "f" (e.g. 3.8/12)	see table "Special versions", depending on handwheel type, only if hub thread "ONG"	
		others on request		
Hub thread	ONG	without hub thread		
	...	thread "n"/measure "f" (e.g. M4/12)	see table "Special versions", depending on handwheel type, only if pinhole "OS"	
		others on request		
Hub turned down	OAN	without turned-down hub		
		others on request		
Position indicator mounted (*)	PM	position indicator mounted		
	PS	separate position indicator		

* separate order of a position indicator required! (see pages 74-82)

Order code



Scope of delivery: HK.../HKL...

Accessories:

Handles
End plate

Page 102
Page 103

Additional information:

General information and areas of application

Page 68 cont.