

Profile

- Miniature control knob with analog display
- Shaft accommodation: max. Ø 10 mm
- Use of normal scales or custom-designed displays
- Fine scaling as an option
- Free choice of mounting situation

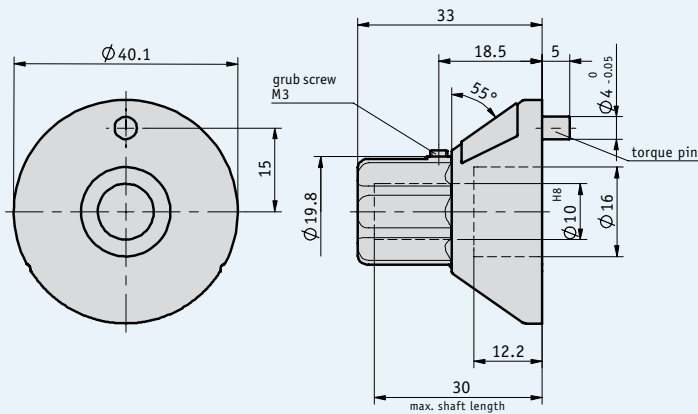

Mechanical data

Feature	Technical data	Additional information
Gear ratio	i = 26	
Ambient temperature	max. 80 °C	
Weight	approx. 16 g	
Housing	plastic	

1.3

Order

Order table

Feature	Order text	Additional information
Bore/diameter	10 A ∅ 10 mm others on request	
Sense of rotation	i B ascending on the right	clockwise
	e ascending on the left	counter-clockwise
Scale	N26 C normal scale 1...26	
	VK special scale	
Scale multi-colored	C1 D 1-color	
	C2 2-color	
	C3 3-color	
Fine scaling	F100 E imprint 0...100	
	OF not imprinted	

Order code

DKA02 - - - - -
A B C D E

Scope of delivery: DKA02

Additional information:

General information and areas of application

Page 44 cont.