

ExDetector HC 150
ExDetector HC 150-K



Data Sheet



Applications/ Set-up

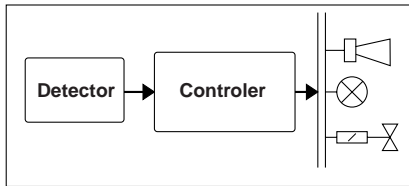

The gas detector ExDetector HC150 in combination with an evaluation system has the following functions:

- Measurement and display of the current concentration of potentially explosive gases and vapours
- Monitoring these gases and warning of their presence
- Triggering protective measures:
 - Technical: measures to prevent the concentration increasing (fans; switching equipment off ...).
 - Organisational: optical and acoustic signals.

A gas warning installation consists of the following components:

- A sensor
- An evaluation system
- Controllable devices such as fans, illuminated warning signs, and solenoid valves

Product Features

- Detection of combustible gases and vapours in air
- Measurement range: 0 ... 100 % LEL
- Measurement principle: catalytic combustion
- Linear measurement signal 4 ... 20 mA
- One-man calibration
- Suitable for areas where there is a Zone 2 explosion hazard

● Models available:

- **HC150:**
Standard, for wall mounting

- **HC150-K:**
For installation in ventilation ducts

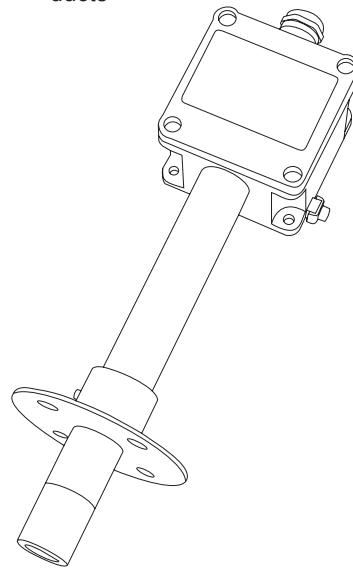
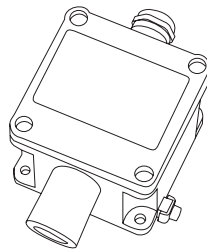

How It Works

The detector electronics regulate the operating parameter (heating voltage) of the sensor. The sensor is made up of active and an inactive elements. The inactive and active sensor elements are connected together in a Wheatstone's bridge circuit to compensate for environmental influences, such as variations in the ambient temperature. As soon as combustible gases reach the active sensor, combustion of the measurement gas occurs. The heat of this reaction changes the electrical resistance and thus the bridge signal. The resultant, small voltage signals are processed and converted to a 4 ... 20 mA measurement signal.

Circuit Block Diagram

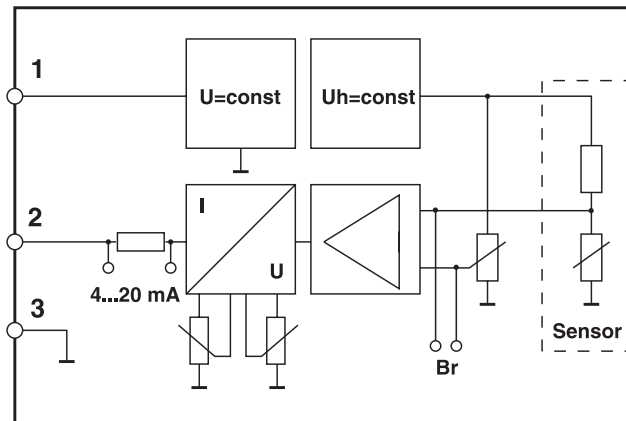

Technical Data

	ExDetector HC 150	ExDetector HC 150-K
ATEX designation	II 3 G Ex nA de IIC T4	
Certificate of conformity	PTB 10 ATEX 1023	
Field of use	Zone 2 hazardous areas	
Category	3	
Equipment group	II	
Atmosphere	G	
Application	Wall-mounting	Ventilation duct mounting
Detectable gases	Combustible gases and vapours 1)	
Measurement range	0 ... 100 % LEL	
Measurement principle	Catalytic combustion (heat of reaction)	
Response time T90	Depends on gas detected (typically < 30 sec)	
Max. flow speed	6 m/sec	
Temperature range	-20 °C ... +55°C	Housing: -20 °C ... +55°C Sensor: -20 °C ... +80°C
Air pressure range	800 ... 1100 hPa	
Humidity range	20 ... 90 % rel. humidity	
Storage conditions	Temperature: -25°C to 60°C Air pressure: 800 hPa to 1100 hPa Humidity: 20% r.h. to 90% r.h.	
Field interface	4 ... 20 mA	
Supply voltage (at sensor terminals)	18 ... 28 VDC SELV / PELV external 100 mA series fuse required	
Max. cable length	1000 m (screened cable)	
Suitable evaluation device	Gas detection computers GMC 8022, GMC 8022E, GMC 8364 or GMC 8420	

1) The useful life of a catalytic combustion sensor is affected by what are known as catalyst poisons. These substances include sulphur, phosphorus, silicon and lead compounds. Corrosive substances which liberate chlorine or fluorine compounds during reactions at the sensor element also reduce the anticipated working life, normally > 3 years.



Mechanical Data

	ExDetector HC 150	ExDetector HC 150-K
Degree of protection (housing)	IP54	
Housing materials	Sensor: stainless steel Housing: aluminium	
Weight	ca. 600 gr	ca. 1600 gr
Cable gland	Cable gland fitting for cable diameter 6... 10 mm	
Connection terminals	0.5 ... 2.5 mm ² (without end sleeve) 0.5 ... 1.5 mm ² (with end sleeve)	

Exdetector HC 150

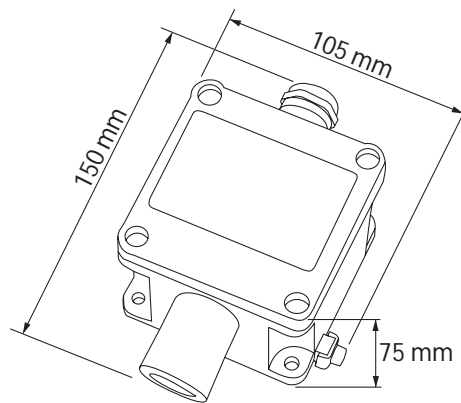

Exdetector HC 150-K

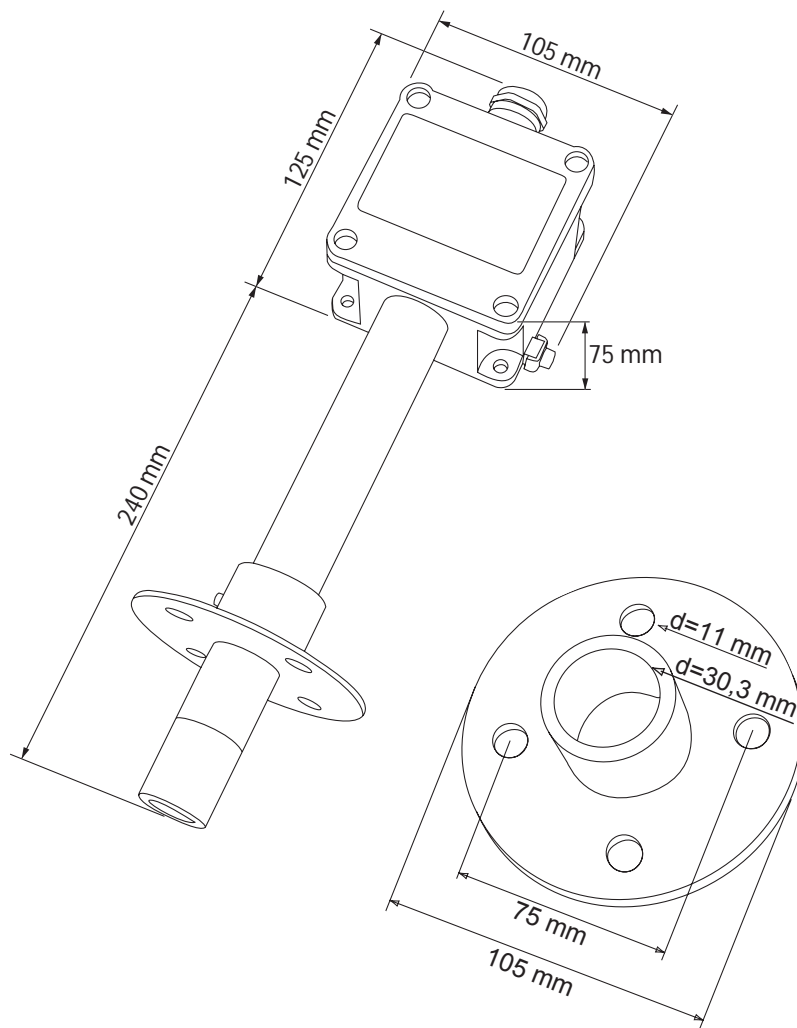

Accessories

- Test gas set
- Calibration gases

Service

Everything from a single supplier - from system design to installation of your new gas warning system. This is backed up with comprehensive coverage by our sales and service network. Ask us about regional representatives in your area. And after purchase our service technicians are ready and willing to help and advise.



Bieler + Lang GmbH
Gas Detection and Warning Systems

PO Box 1129, D-77842 Achern
Von-Drais-Straße 31, D-77855 Achern

Telephone +49 (0) 78 41 69 37 - 0
Telefax +49 (0) 78 41 69 37 - 99
E-mail info@bieler-lang.de

Internet www.bieler-lang.de

We reserve the right to make technical changes!