



Alfa Laval Primary Tank 5 bar

Thermal storage vessel for Primary side / 300-3000 litres

Alfa Laval Primary Tank is suitable to store large quantities of heated **primary** water from different heat sources such as boilers, hydraulic networks, solar heaters or any other heat recovery system. The Tank is designed for use in combination with a tap water system like Alfa Laval AquaFirst, AquaEfficiency or AquaFlow/Store and also high efficient heat interface units, such as type Mini City.

Applications

The Primary Tank stores energy to generate hot primary water on demand in facilities where sudden high demands occur on a fairly regular basis such as:

- apartment blocks
- hospitals, retirement and nursing homes
- hotels
- schools
- leisure centres
- any other collective building

Benefits

- Energy saving solution as reduces the boiler or network capacity
- Hygienic solution: no risks of legionella, even at low temperature thanks to the water being stored on the primary side
- Maximum hot water production thanks to its specific internal tube arrangement avoiding mixing of the cold water return loop with the stored hot water
- Easy handling thanks to 2 ring bolts on top of the Primary Tank
- Delivered with feet to facilitate the cold water inlet connection and emptying, and to maximize the total available volume
- Insulation - standard 100mm - easy to remove and refit
- Reduces the risk of lime scaling if combined with the 3-port mixing valve of the AquaFirst, AquaEfficiency or AquaFlow/Store unit, especially if combined with thermal solar installation
- Additional connections to optimize condensation and the heating of boilers
- Low total cost of ownership



Characteristics

Volumes	300 to 3000 litres
Material	Carbon steel, conform PED 97/23CE
Outer coating	Painted
Insulation	M1: 100mm glass wool covered with PVC jacket, European fireclass B M0: 100mm rockwool clad with aluminium metal plate, European fireclass A
Maximum operation temperature	100°C
Maximum operating pressure bar gauge	5 bar g
Connections	All connections are female threads All 1/2" connections are dedicated for additional instruments like temperature sensors

Flowchart and working principle

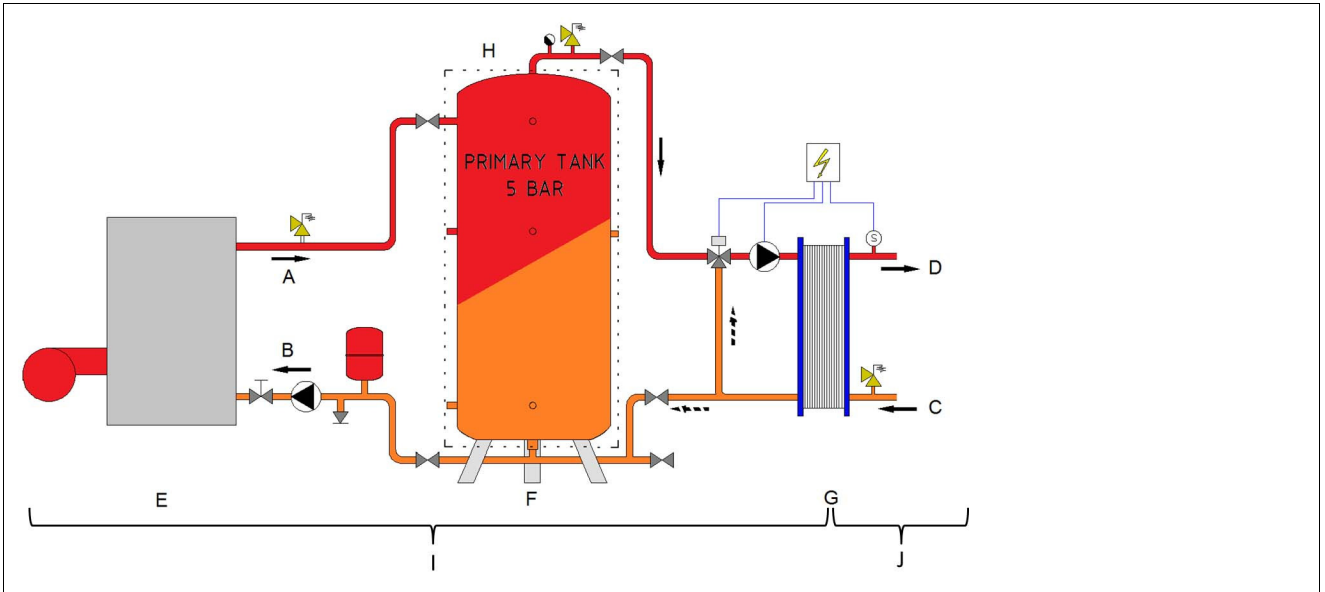

- | | | |
|---------------------------------|--------------------------------|------------------|
| A Primary heating water inlet | E Local boiler | I Primary side |
| B Primary heating water outlet | F Return from tap water system | J Secondary side |
| C Secondary return from network | G Tap water system | |
| D Secondary outlet to network | H To tap water system | |

In the tap water system (G), energy is exchanged through a heat exchanger from the primary (I) to the DHW side (J). On the primary side, the DHW unit has to be fed by a heating source that can be provided for example by a local boiler (E) and the Alfa Laval Primary Tank 5 bar. In the case of the Primary Tank, the required DHW unit primary flow rate comes from the top of the Primary Vessel. This flow rate (H) is a combination of the flow rate coming from the bottom of the vessel (F) and the additional flow rate (A) coming from the boiler. This storage tank ensures that DHW primary flowrate supply is met during peak demand periods.

Sizing

The "total peak need for Domestic Hot Water" (DHW) = "nominal capacity of a tap water system" + "volume of the stored DHW" on secondary side used in 10min.

How to size an equivalent solution with the Primary Tank 5 bar?

- Design the DHW on the "total peak need for Domestic Hot Water" required
- Design the Primary Tank 5 bar with the above calculated "volume of the stocked DHW" X 1,4

Example for 71 standard apartments:

Requested capacity for a Direct (Instantaneous) tap water system of 300 kW with an available capacity of the boiler of 100 kW:

- Offer for an Indirect (Semi-instantaneous) tap water system, 100 kW boiler and a secondary DHW storage tank would be:
 - Indirect (Semi-instantaneous) tap water system: 100 kW (G = E)
 - Volume DHW storage tank: **1000L**
- Offer with a Direct (Instantaneous) tap water system, 100 kW boiler and the Primary Tank 5 bar would be:
 - Direct (Instantaneous) tap water system: 300 kW
 - Volume of the Primary Tank 5 bar: 1,4 X 1000L = **1400L**

In this example the solution will be the Primary Tank 5 bar of 1500L (see next page).

Drawing & Selection table

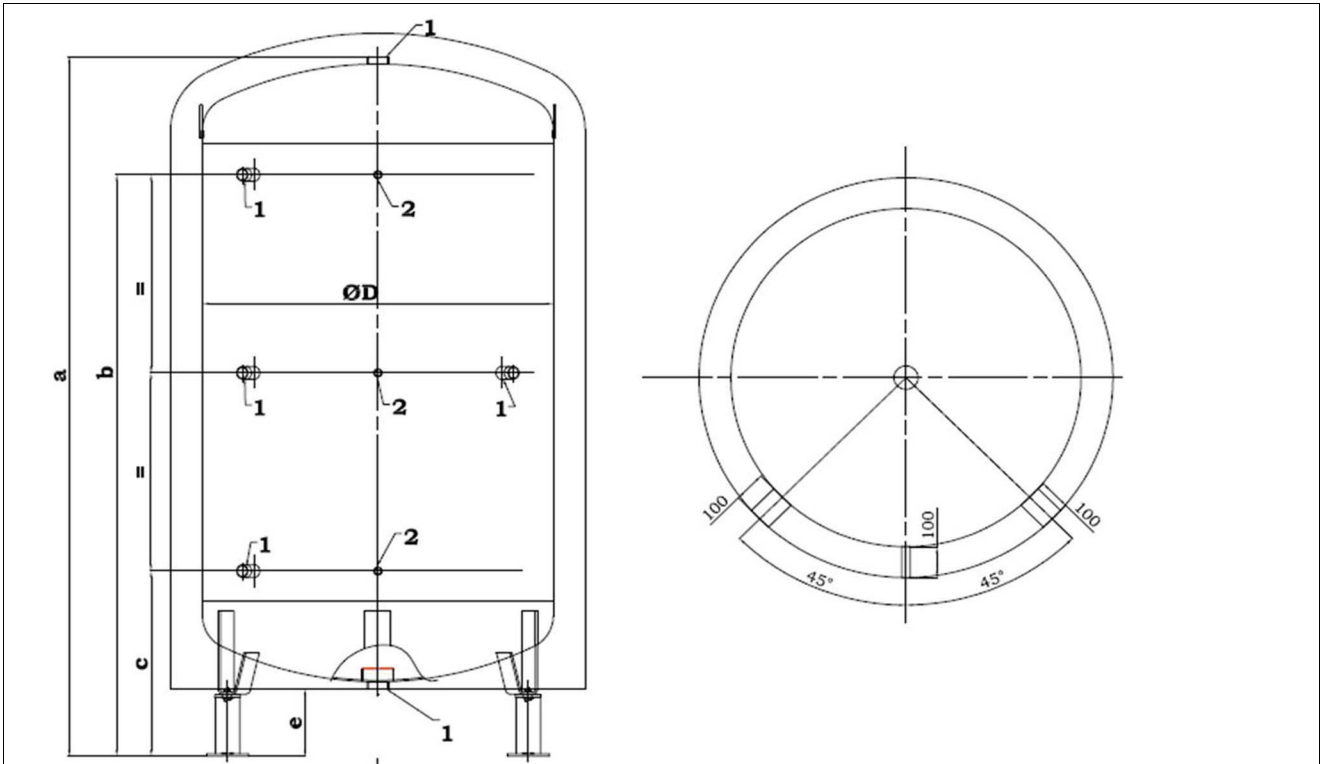

Volume (L)	Dimensions (mm)					Connection sizes (inch)		Insulations Cooling constant during 24 hours [(kWh/nb of litres)/DeltaT]		Heat loss during 24 hours (kWh)		Article Numbers Primary Tank 5 bar with insulation M1	Dry weight	Article Numbers Primary Tank 5 bar with insulation M0	Dry weight
	a	b	c	D	e	1	2	M1	M0	M1	M0	M1	Kg	M0	Kg
	Rp 2"		Rp 1 1/2"												
300	1410	1150	458	630	200	Rp 2"	Rp 1 1/2"	0,00018	0,00011	2,7	1,7	AQTVP030M1	68	AQTVP030M0	98
500	2012	1753	464	630	205			0,00017	0,00011	4,1	2,6	AQTVP050M1	96	AQTVP050M0	130
750	1907	1600	500	790	193			0,00013	0,00008	4,9	3,2	AQTVP075M1	120	AQTVP075M0	160
1000	2260	1953	500	790	193			0,00011	0,00007	5,5	3,7	AQTVP100M1	160	AQTVP100M0	220
1500	2083	1699	599	1100	212			0,00008	0,00007	6,3	5	AQTVP150M1	244	AQTVP150M0	324
2000	2274	1887	599	1100	212			0,00008	0,00006	7,5	5,9	AQTVP200M1	264	AQTVP200M0	364
2500	2145	1679	679	1400	214			0,00007	0,00005	8,5	6,6	AQTVP250M1	367	AQTVP250M0	470
3000	2274	1809	679	1400	214			0,00006	0,00005	9,7	7,6	AQTVP300M1	398	AQTVP300M0	530

How to contact Alfa Laval

Up-to-date AlfaLaval contact details for all countries are always available on our website on www.alfalaval.com