

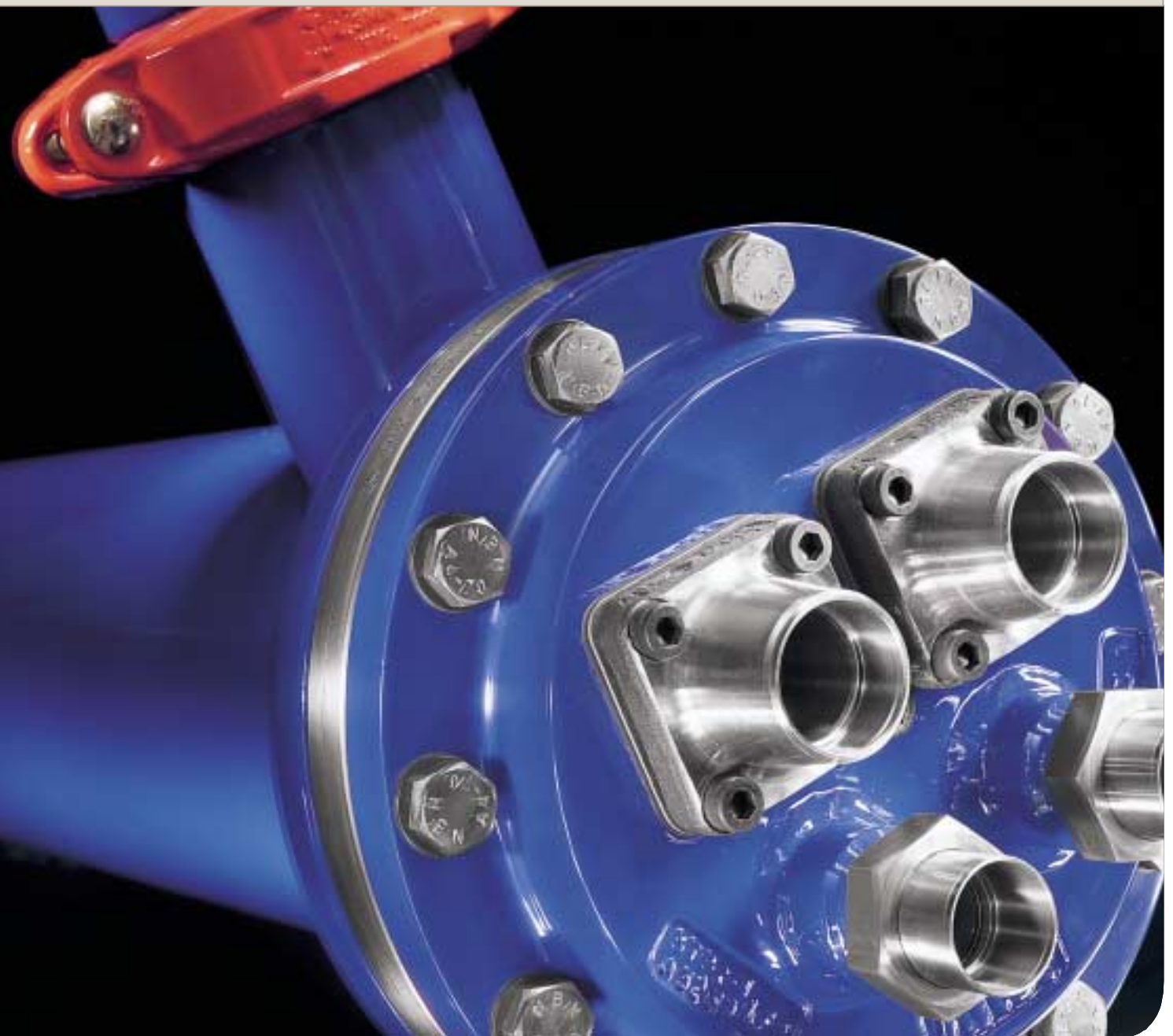

Dryplus-3 shell & tube evaporators

Dry expansion evaporators optimised for the air conditioning and refrigeration world



Dryplus-3 shell & tube evaporators

- 4 Excellence and flexibility in performance
 - Performances and features
- 5 Perfection in construction
 - Integrate water tank solutions
- 6 Quality and approvals
- 7 Auxiliary connections
 - Supports
- 8 18-47 kW
- 9 56-95 kW
- 10 120-165 kW
- 11 200-240 kW
- 12 300-345 kW
- 13 385-450 kW
- 14 505-570 kW
- 15 660-770 kW
- 16 915-1000 kW
- 17 1100-1500 kW
- 18 COMPACT 160-210 kW
- 19 COMPACT 235-275 kW
- 20 COMPACT 390-480 kW
- 21 Refrigerant connections
- 22 Water connections
- 23 IT - Integrate water tank solutions

Dryplus-3 series of shell and tube evaporators represent the natural technological evolution of a generation of heat exchangers leader in the air conditioning and refrigeration applications.

The models of the series ensure cooling capacities up to 1500 kW at nominal conditions, from 1 to 4 independent cooling circuits, 3 different baffle distances depending on the working water flows and 3 different positions of the water connections.

In particular, the evaporators have been optimised for opera-

tion with R407C refrigerant. The adoption of a dedicate, high efficiency exchange tube allowed to exalt performances increasing the cooling capacities by values close to 10%. This performance improvement can be alternatively translated into a raising of the evaporation temperature and then in an optimisation of the COP of the cooling system, not only in combination with R407C but also with the other refrigerants. Particular attention has been paid to the lubricant oil flow aspect.

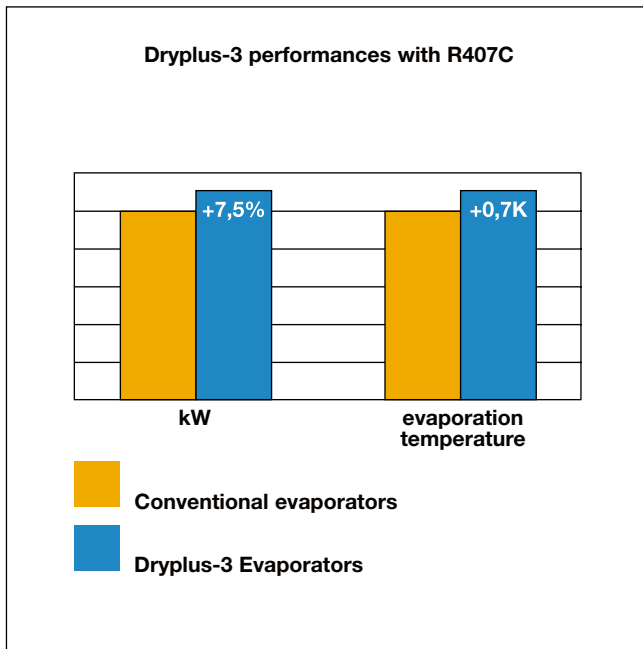
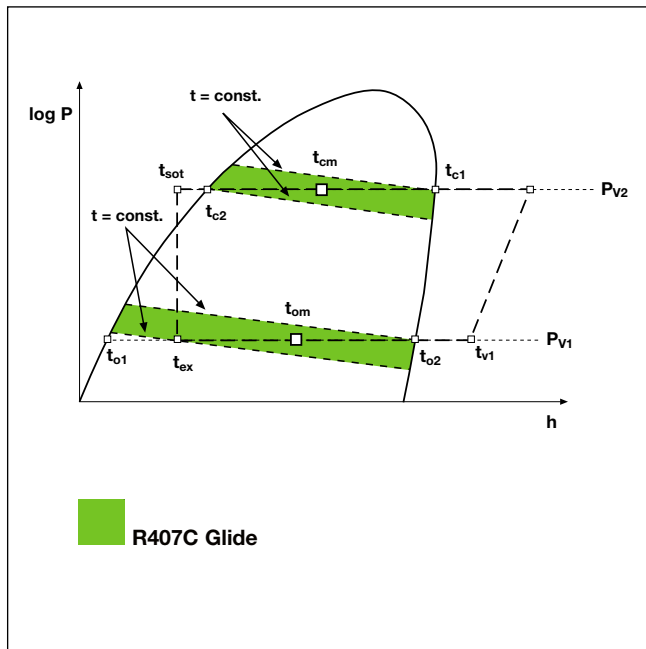

*Average results on the different models in the 135-1000 kW range

Performances and features

1. The first shell and tube evaporator optimised for R407C
2. Exalted performances with no size increase, thanks to new high efficiency tubes and design
3. Exchange tubes designed to ensure a safe flow for the most viscous lubricant oils
4. Reduced water side pressure drops
5. A range designed to operate as a standard in heat pump mode
6. 3 baffle distances available
7. Extractable tube bundle
8. Stainless steel versions
9. Reduced length versions
10. IT integrate water tank solutions



Perfection in construction

Alfa Laval shell and tube evaporators include the results of a research intended to ensure a high level of mechanical strength and resistance to vibration and corrosion. The "U" design of the tube bundle allows the thermal expansion between the tubes and the shell avoiding any tension. Thanks to this solution the tube bundle can be extracted from the shell for inspection or maintenance (starting with model DX_56) and it is possible to rotate the shell in order to change the water connection position.

The material choice is linked not only to heat exchange targets, but also to pressure design needs due to years of intensive usage:

- Header, tube sheet, shell, refrigerant and water connections

are made of carbon steel;

- High efficiency exchange tubes are in copper, internally finned;
- Baffles are made of brass or other suitable material (carbon steel);
- The bolt system is made of steel alloys or stainless steel depending on working conditions and temperatures, while gaskets are made of an asbestos free compound.

Evaporators are available in stainless steel execution (AISI 316) following the requests (in the configurations tube sheet and exchange tubes; shell, tube sheet and exchange tubes; the whole unit in stainless steel).

Three different insulation versions are available.

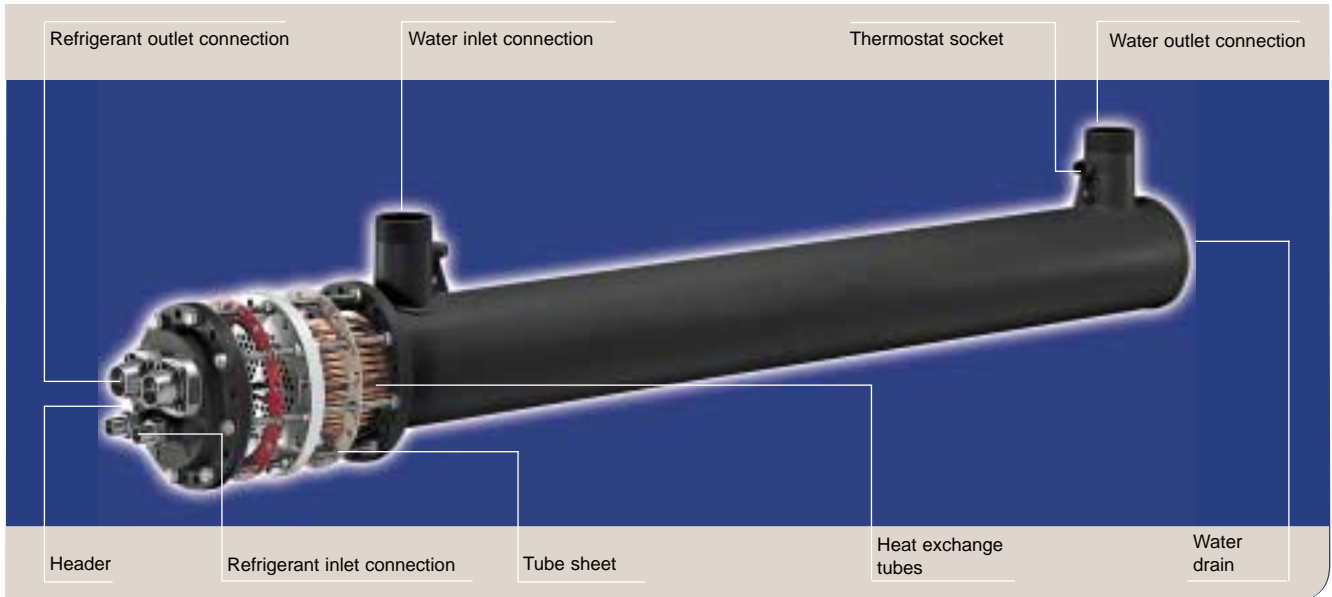

Integrate water tank solutions

To integrate in one unique solution a shell and tube evaporator and a water tank. The logic that supports the IT (Integrated Tank) solution is simple and profitable:

- This solution reduces considerably the space occupied by these two components, allowing to place a water tank where this operation would be not possible, as in several package chiller models;
- Two versions are available: water flow with storage before or after

the evaporator. In the second case the advantage is the creation of a reservoir of cold water which tends to stabilize the outlet water temperature and reduces in this way the number of start-ups of the compressors;

- The whole integrate solution (evaporator and tank) is CE approved, completely tested and supplied with supports. IT integrated water tanks are available in 9 sizes, from 240 to 3000 litres.



Quality means to count on a design and a manufacturing process certified according to ISO9001 and to offer the widest range of pressure vessel approvals. On request, it is possible to obtain certifications by the major marine classification bodies.

Each Alfa Laval evaporator undergoes to the following tests:

- Pressure test refrigerant and water side at the pressure values and following the process indicated by the Alfa Laval standard or by the chosen pressure vessel code;
- Differential pressure test of the single refrigerant circuits;
- Leakage test with helium (maximum acceptable leakage value is 3 g/yr of R22).

After tests, the cooling circuit is dried and protected with adsorbing charges.



Nominal data DX_18-DX_1000		CE		Alfa Laval std.		UDT		ASME*	SQL		GOST	
		STD	BT	STD	BT	STD	BT	STD	STD	BT	STD	BT
DP refrig.	bar	29	21	25	21	24.5	21	15.5	24.5	21	24.5	21
TP refrig.	bar	41.5	30	27.5	23.1	27.5	23.1	17.05	27	23.1	27	23.1
DP water	bar	16	16	10	10	10	10	10	10	10	10	10
TP water	bar	22.8	15	15	15	15	15	11	15	15	15	15
DT	°C	-10	-40	-10	-40	-10	-40	-10	-10	-40	-10	-40
		+90	+50	+90	+50	+90	+50	+90	+90	+50	+90	+50

*ASME approval includes models starting with size 56 (shell diameter ≥6"). Models 18-47 are UL approved.

Nominal data DX_1100-DX_1500		CE		Alfa Laval std.		UDT		ASME	SQL		GOST	
		STD	BT	STD	BT	STD	BT	STD	STD	BT	STD	BT
DP refrig.	bar	20	20	20	20	20	20	15.5	20	20	20	20
TP refrig.	bar	28.6	28.6	22	22	22	22	17.05	22	22	22	22
DP water	bar	16	16	10	10	10	10	10	10	10	10	10
TP water	bar	22.8	15	15	15	15	15	11	15	15	15	15
DT	C°	-10	-40	-10	-40	-10	-40	-10	-10	-40	-10	-40
		+90	+50	+90	+50	+90	+50	+90	+90	+50	+90	+50

DP: design pressure
TP: test pressure
DT: design temperature



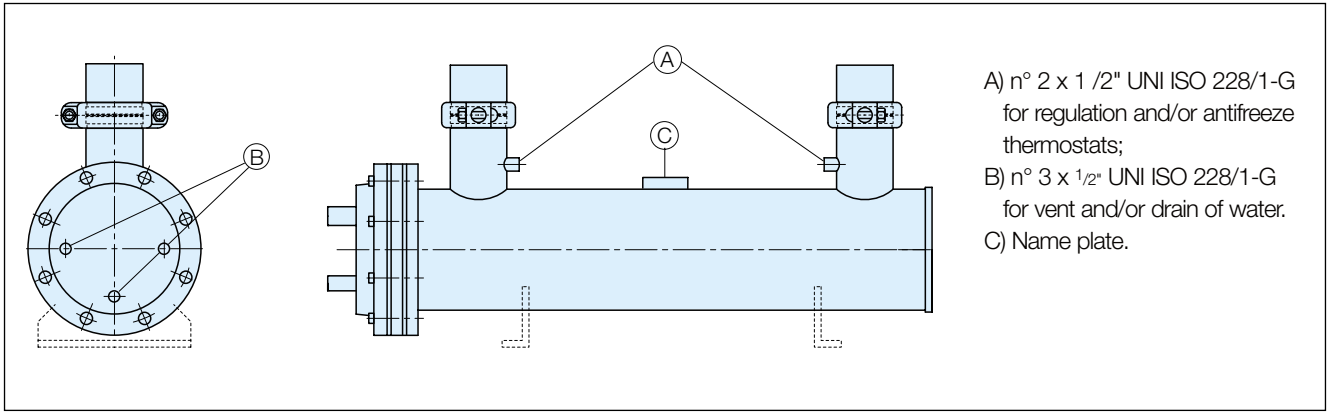

Supports

Alfa Laval evaporators can be equipped with supports welded to the shell (illustrated in the technical data pages which are following) or with universal brackets which are positioned in the installation phase and allows therefore the maximum flexibility (available up to shell diameter 406 mm).

Universal Brackets: dimensions (mm)												
Code	A	B		C	D	E	F	SLOTS			I	L
		min	max					G	H	Type		
55341700	140	82	178	220	60	50	40	12	60	1	25	-
55341710	168	112	208	250	60	50	40	12	60	1	25	-
55341720	194	46	238	280	60	50	40	12	60	2	15	32
55341730	219	82	276	320	80	50	40	12	60	2	15	32
55341740	273	176	352	400	100	60	50	16	60	2	17	38
55341750	324	108	372	420	100	60	50	16	60	3	17	38
55341760	406	216	468	520	120	80	60	18	60	3	20	54

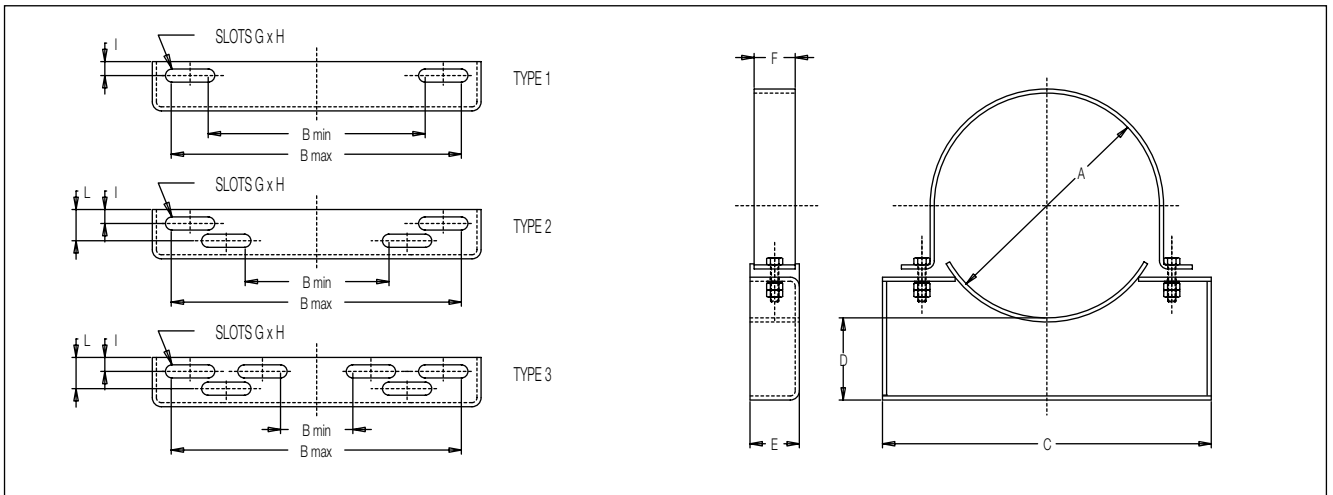

ORDERING CODE

DXD	300	—	H	BT	CE
Model	Nominal capacity	Water connect. position	Baffles span	Design temperature	Approval
DXS DXD DXT DXQ	kW	— = Top DX = Right SX = Left	— = Standard distance H = Short distance X = Shorter distance	— = Standard BT = Low temp.	CE UDT ASME GOST SQL

Nominal Conditions	Model	DXS18	DXS28	DXS35 DXD35	DXS47 DXD47
Refrig.: R407c T_{IN} brine = 12°C T_{OUT} brine = 7°C (8°C DXS18/28) T_c (dew) = 45.26°C T_a (dew) = 2.75°C ΔT_{sc} = 3K; ΔT_{sh} = 5K Lubricant oil ISO68	Q_{nom} [kW]	18,6	28,2	35,1	47
	W_{nom} [m³/h]	4	6	6	8
	W_{max} [m³/h]	6,3	8	10	11,4
	Δp_{nom} [bar]	0,16	0,29	0,27	0,41

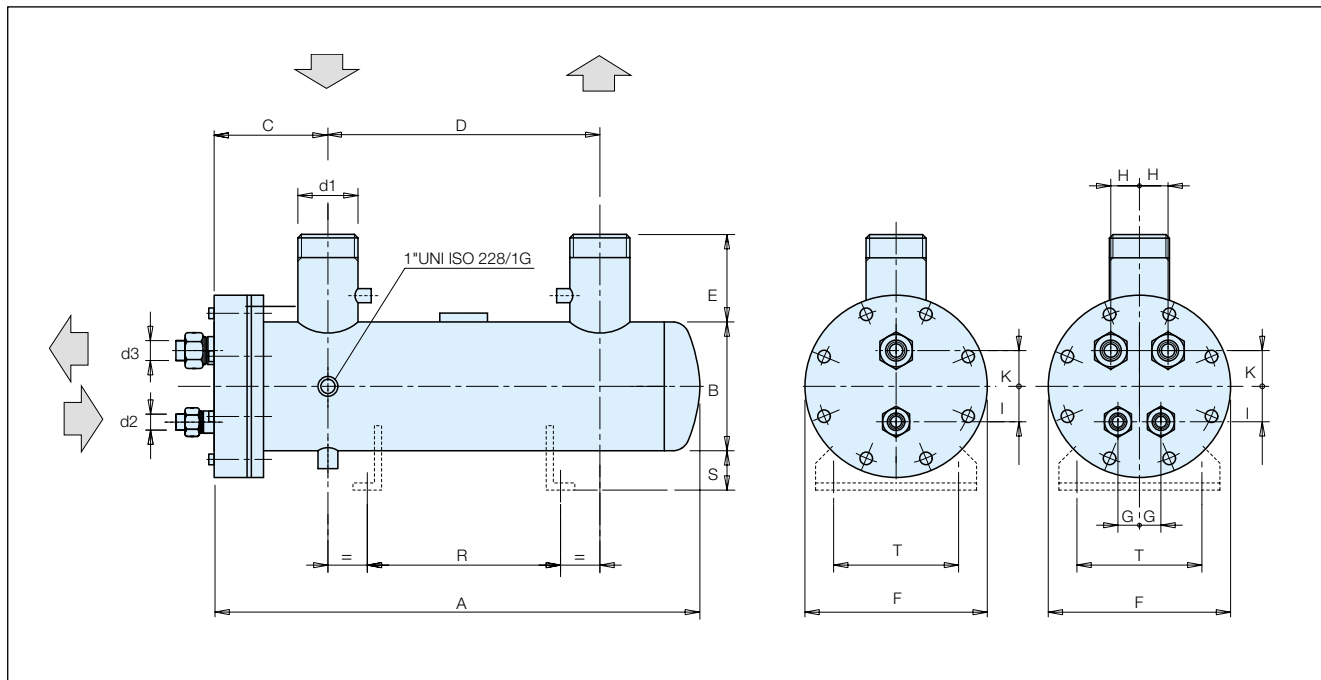

MODEL			DXS 18	DXS 28	DXS 35	DXD 35	DXS 47	DXD 47
Dimensions	A	mm	887	1037	1257	1257	1407	1407
	B	mm	140	140	140	140	140	140
	C	mm	97	97	107	107	107	107
	D	mm	690	840	1040	1040	1190	1190
	E	mm	130	130	130	130	130	130
	F	mm	195	195	195	195	195	195
	G	mm	-	-	-	30	-	30
	H	mm	-	-	-	35	-	35
	K	mm	30	30	30	30	30	30
	I	mm	32	32	32	30	32	30
	L	mm	-	-	-	-	-	-
	M	mm	-	-	-	-	-	-
O	mm	-	-	-	-	-	-	
Support	R	mm	550	650	800	800	950	950
	S	mm	60	60	60	60	60	60
	T	mm	160	160	160	160	160	160
Connections	d1	-	T11	T11	T2	T2	T2	T2
	d2	-	RB-22	RB-22	RB-22	RA-16	RB-22	RA-16
	d3	-	RC-35	RC-35	RC-35	RC-28	RC-35	RC-28
Volumes - Weight	V_R	dm³	3,5	4,2	5	5	5,7	5,7
	V_{H_2O}	dm³	6,7	7,9	9,5	9,5	11	11
	P	kg	33	37	42	42	45	45
PED category*			I	I	I	I	I	I

*PED category according to EU Directive 97/23/EC.

The category refers to the use of Group 2 fluids at the PS value of the standard temperature version.

Q_{nom} Nominal cooling capacity

W_{nom} Nominal water flow

W_{max} Maximum water flow

Δp_{nom} Nominal pressure drop (water side)

ΔT_{sc} Subcooling

ΔT_{sh} Superheating

Nominal Conditions	Model	DXS56 DXD56	DXS65 DXD65	DXS80 DXD80	DXS95 DXD95
Refrig.: R407c $T_{IN, brine} = 12^{\circ}\text{C}$ $T_{OUT, brine} = 7^{\circ}\text{C}$ $T_{c(dew)} = 45.26^{\circ}\text{C}$ $T_{v(dew)} = 2.75^{\circ}\text{C}$ $\Delta T_{sc} = 3\text{K}; \Delta T_{sh} = 5\text{K}$ Lubricant oil ISO68	Q_{nom} [kW]	56	65	80	95
	W_{nom} [m ³ /h]	9,6	11,4	13,8	16,4
	W_{max} [m ³ /h]	12	14,5	18	21
	Δp_{nom} [bar]	0,35	0,39	0,42	0,46

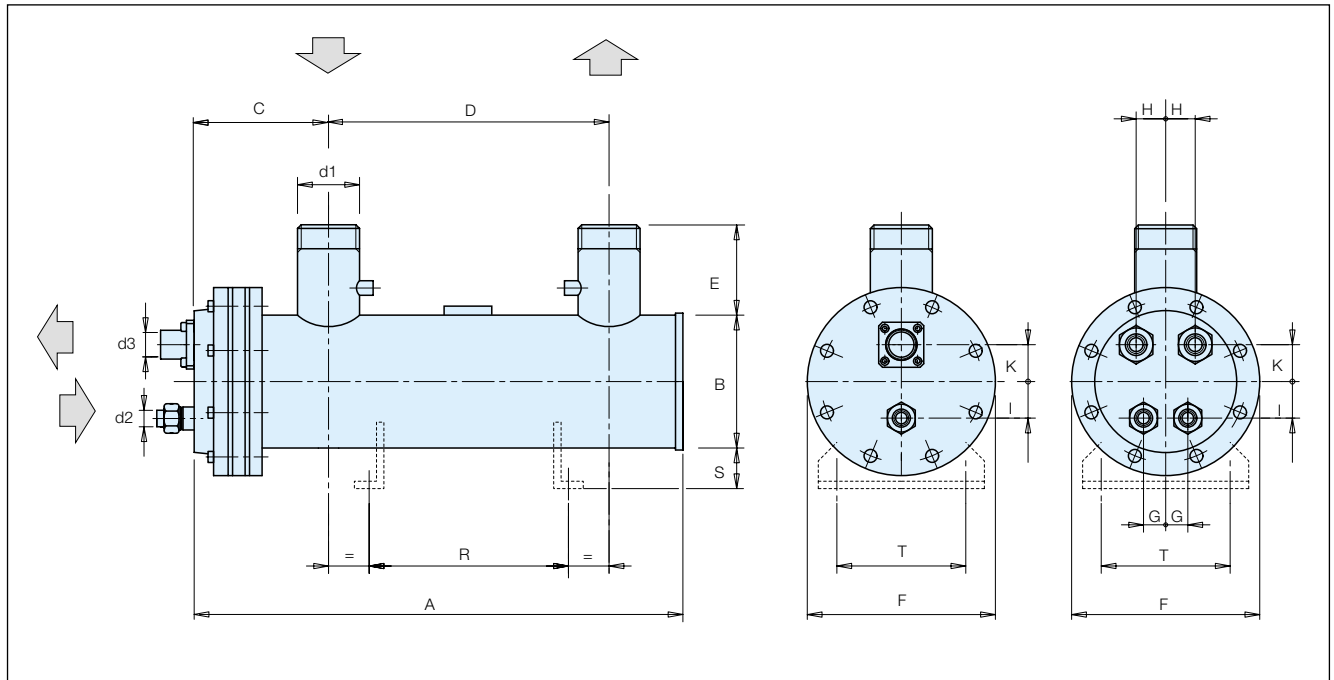

MODEL			DXS 56	DXD 56	DXS 65	DXD 65	DXS 80	DXD 80	DXS 95	DXD 95
Dimensions	A	mm	1281	1281	1431	1431	1631	1631	1781	1781
	B	mm	168	168	168	168	168	168	168	168
	C	mm	161	161	161	161	161	161	161	161
	D	mm	1030	1030	1180	1180	1380	1380	1530	1530
	E	mm	130	130	130	130	130	130	130	130
	F	mm	245	245	245	245	245	245	245	245
	G	mm	-	35	-	35	-	35	-	35
	H	mm	-	40	-	40	-	40	-	40
	K	mm	37	30	37	30	37	30	37	30
	I	mm	45	35	45	35	45	35	45	35
	L	mm	-	-	-	-	-	-	-	-
	M	mm	-	-	-	-	-	-	-	-
	O	mm	-	-	-	-	-	-	-	-
Support	R	mm	800	800	950	950	1100	1100	1200	1200
	S	mm	60	60	60	60	60	60	60	60
	T	mm	160	160	160	160	160	160	160	160
Connections	d1	—	T21	T21	T21	T21	T21	T21	T21	T21
	d2	—	RB-22	RB-22	RB-22	RB-22	RB-22	RB-22	RB-22	RB-22
	d3	—	FB-54	RC-35	FB-54	RC-35	FB-54	RC-35	FB-54	RC-35
Volumes - Weight	VR	dm ³	7,3	7,3	8,2	8,2	9,3	9,3	10,2	10,2
	V _{H₂O}	dm ³	15,3	15,3	17,2	17,2	19,8	19,8	21,7	21,7
	P	kg	67	67	72	72	77	77	81	81
PED category*			II	I	II	I	II	I	II	I

*PED category according to EU Directive 97/23/EC.

The category refers to the use of Group 2 fluids at the PS value of the standard temperature version.

Q_{nom} Nominal cooling capacity

W_{nom} Nominal water flow

W_{max} Maximum water flow

Δp_{nom} Nominal pressure drop (water side)

ΔT_{sc} Subcooling

ΔT_{sh} Superheating

Nominal Conditions	Model	DXS120-DXD120 DXT120	DXS135-DXD135 DXT135	DXS165-DXD165 DXT165
Refrig.: R407c $T_{IN\ brine} = 12^{\circ}C$ $T_{OUT\ brine} = 7^{\circ}C$ $T_{c(dew)} = 45,26^{\circ}C$ $T_{v(dew)} = 2,75^{\circ}C$ $\Delta T_{sc} = 3K; \Delta T_{sh} = 5K$ Lubricant oil ISO68	Q_{nom} [kW]	120	135	165
	W_{nom} [m ³ /h]	20,6	23,2	28,3
	W_{max} [m ³ /h]	25	28	30
	Δp_{nom} [bar]	0,29	0,44	0,50

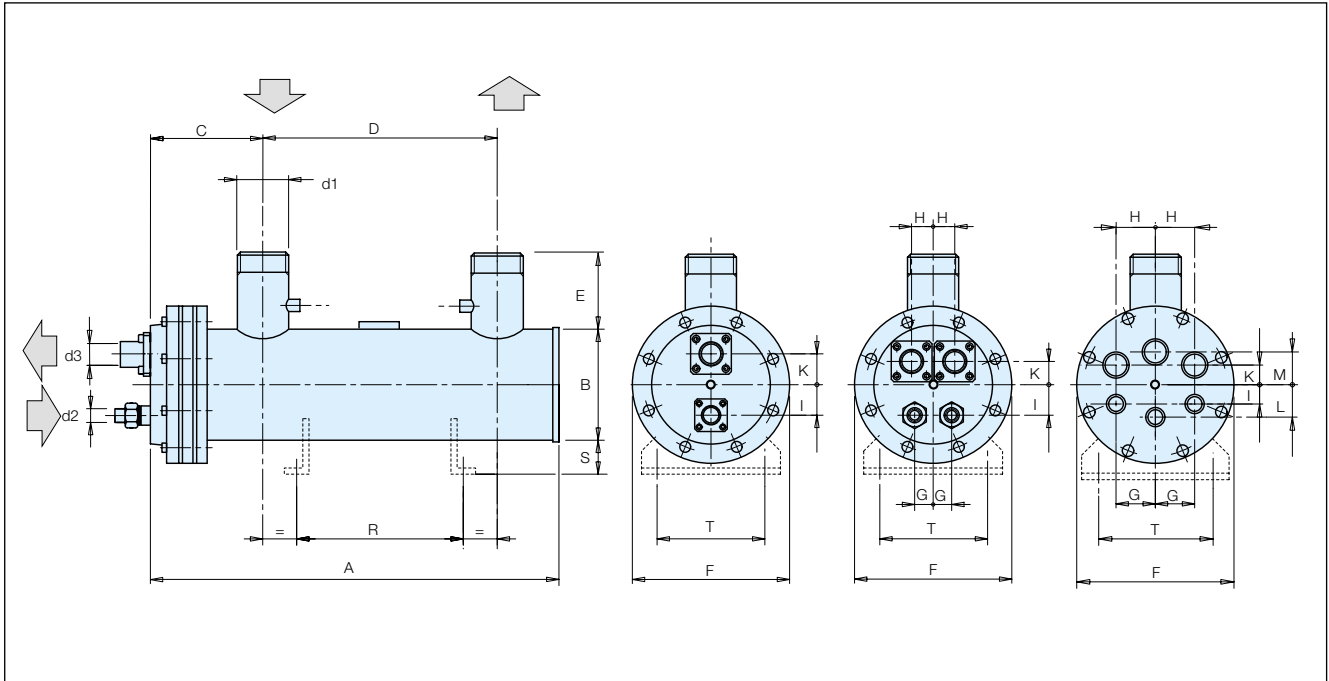

MODEL		DXS 120	DXD 120	DXT 120	DXS 135	DXD 135	DXT 135	DXS 165	DXD 165	DXT 165	
Dimensions	A	mm	1815	1815	1810	2115	2115	2110	2315	2315	
	B	mm	194	194	194	194	194	194	194	194	
	C	mm	180	180	175	180	180	175	180	180	
	D	mm	1530	1530	1530	1830	1830	1830	2030	2030	
	E	mm	130	130	130	130	130	130	130	130	
	F	mm	270	270	270	270	270	270	270	270	
	G	mm	-	35	50	-	35	50	-	35	50
	H	mm	-	47	60	-	47	60	-	47	60
	K	mm	45	28	30	45	28	30	45	28	30
	I	mm	45	35	30	45	35	30	45	35	30
	L	mm	-	-	40	-	-	40	-	-	40
M	mm	-	-	43	-	-	43	-	-	43	
O	mm	-	-	-	-	-	-	-	-	-	
Support	R	mm	1200	1200	1200	1500	1500	1500	1700	1700	
	S	mm	60	60	60	60	60	60	60	60	
	T	mm	160	160	160	160	160	160	160	160	
Connections	d1	—	T3	T3	T3	T3	T3	T3	T3	T3	
	d2	—	FA-35	RB-22	WA-22	FA-35	RB-22	WA-22	FA-35	RB-22	
	d3	—	FB-54	FA-42	WA-35	FB-67	FA-42	WA-35	FB-67	FA-42	
Volumes - Weight	VR	dm ³	13,8	13,8	13,8	16,2	16,2	16,2	17,8	17,8	
	V _{H₂O}	dm ³	30	30	30	35,2	35,2	35,2	38,8	38,8	
	P	kg	107	107	107	118	118	118	125	125	
PED category*			II	I	I	II	II	I	II	II	

*PED category according to EU Directive 97/23/EC.

The category refers to the use of Group 2 fluids at the PS value of the standard temperature version.

Q_{nom} Nominal cooling capacity

W_{nom} Nominal water flow

W_{max} Maximum water flow

Δp_{nom} Nominal pressure drop (water side)

ΔT_{sc} Subcooling

ΔT_{sh} Superheating

Nominal Conditions	Model	DXS200 - DXD200 DXT200 - DXQ200	DXS240 - DXD240 DXT240 - DXQ240
Refrig.: R407c $T_{N, \text{brine}} = 12^{\circ}\text{C}$ $T_{\text{OUT, brine}} = 7^{\circ}\text{C}$ $T_c(\text{dew}) = 45.26^{\circ}\text{C}$ $T_{\text{vap}}(\text{dew}) = 2.75^{\circ}\text{C}$ $\Delta T_{\text{sc}} = 3\text{K}; \Delta T_{\text{sh}} = 5\text{K}$ Lubricant oil ISO68	Q_{nom} [kW]	200	240
	W_{nom} [m ³ /h]	34,2	41,1
	W_{max} [m ³ /h]	41	43
	Δp_{nom} [bar]	0,38	0,50

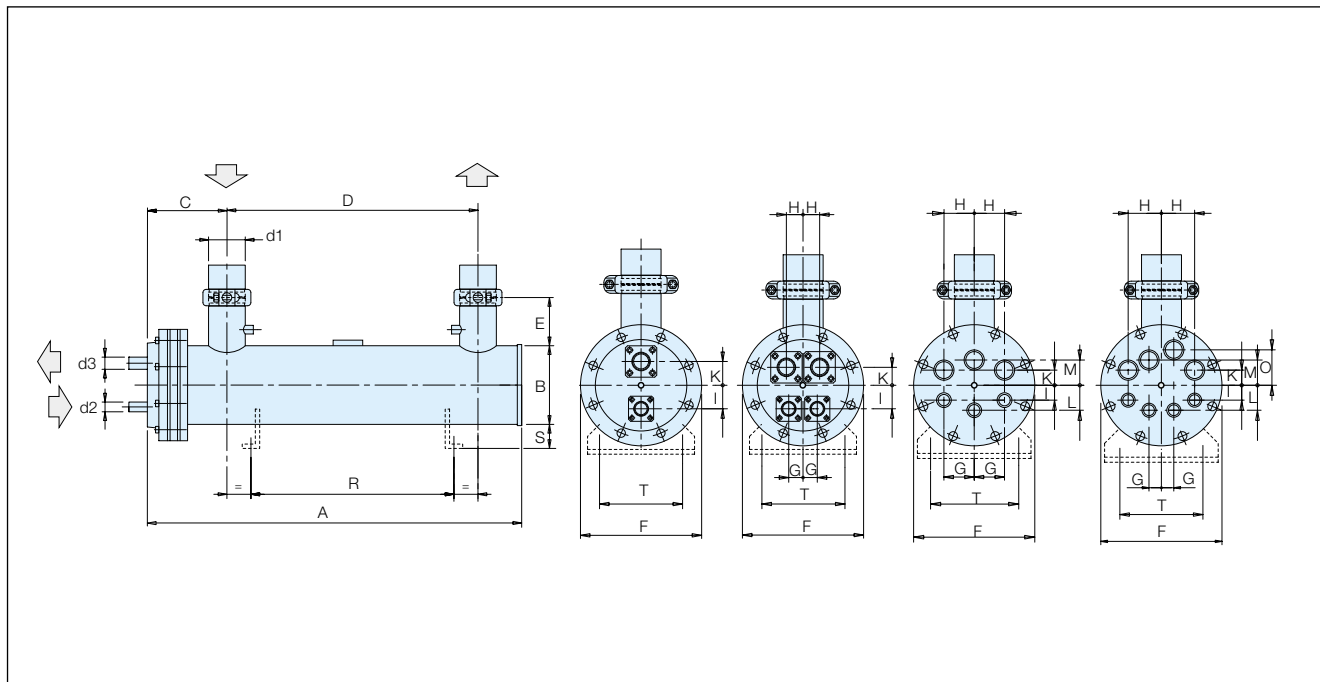

MODEL			DXS 200	DXD 200	DXT 200	DXQ 200	DXS 240	DXD 240	DXT 240	DXQ 240
Dimensions	A	mm	2320	2320	2312	2312	2620	2620	2612	2612
	B	mm	219	219	219	219	219	219	219	219
	C	mm	200	200	192	192	200	200	192	192
	D	mm	2000	2000	2000	2000	2300	2300	2300	2300
	E	mm	150	150	150	150	150	150	150	150
	F	mm	310	310	310	310	310	310	310	310
	G	mm	-	42	65	21	-	42	65	21
	H	mm	-	46	65	75	-	46	65	75
	K	mm	46	36	35	36	46	36	35	36
	I	mm	55	44	35	42	55	44	35	42
	L	mm	-	-	55	50	-	-	55	50
M	mm	-	-	65	42	-	-	65	42	
O	mm	-	-	-	75	-	-	-	75	
Support	R	mm	1600	1600	1600	1600	1800	1800	1800	1800
	S	mm	80	80	80	80	80	80	80	80
	T	mm	260	260	260	260	260	260	260	260
Connections	d1	—	J4	J4	J4	J4	J4	J4	J4	J4
	d2	—	FA-35	RC-35	WA-22	WA-22	FA-35	RC-35	WA-22	WA-22
	d3	—	FB-67	FA-54	WA-42	WA-35	FB-67	FA-54	WA-42	WA-35
Volumes - Weight	V _R	dm ³	23,7	23,7	23,7	23,7	26,8	26,8	26,8	26,8
	V _{H₂O}	dm ³	49,3	49,3	49,3	49,3	56	56	56	56
	P	kg	157	157	157	157	175	175	175	175
PED category*			II	II	II	I	II	II	II	I

*PED category according to EU Directive 97/23/EC.

The category refers to the use of Group 2 fluids at the PS value of the standard temperature version.

Q_{nom} Nominal cooling capacity

W_{nom} Nominal water flow

W_{max} Maximum water flow

Δp_{nom} Nominal pressure drop (water side)

ΔT_{sc} Subcooling

ΔT_{sh} Superheating

Nominal Conditions	Model	DXS300 - DXD300 DXT300 - DXQ300	DXS345 - DXD345 DXT345 - DXQ345
Refrig.: R407c $T_{IN\ brine} = 12^{\circ}C$ $T_{OUT\ brine} = 7^{\circ}C$ $T_c(dew) = 45,26^{\circ}C$ $T_{vap}(dew) = 2,75^{\circ}C$ $\Delta T_{sc} = 3K$; $\Delta T_{sh} = 5K$ Lubricant oil ISO68	Q_{nom} [kW]	300	345
	W_{nom} [m ³ /h]	51,4	59,1
	W_{max} [m ³ /h]	65	68
	Δp_{nom} [bar]	0,48	0,42

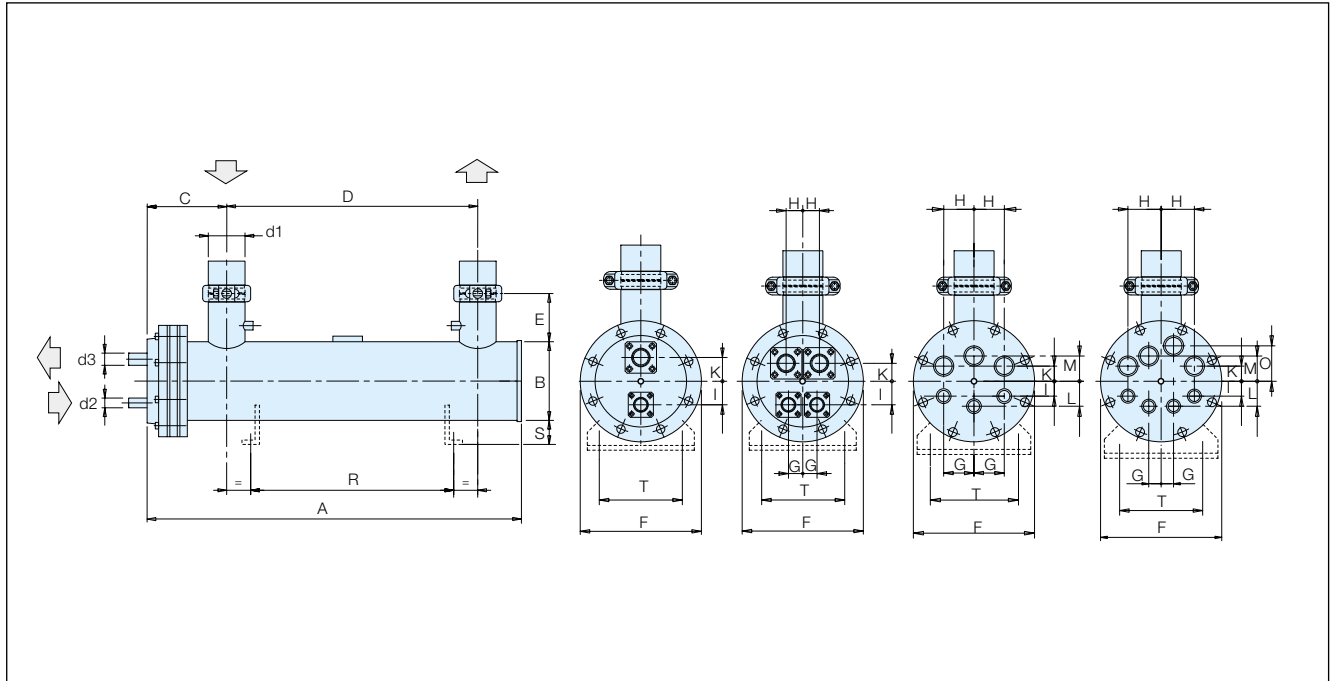

MODEL			DXS 300	DXD 300	DXT 300	DXQ 300	DXS 345	DXD 345	DXT 345	DXQ 345
Dimensions	A	mm	2654	2654	2648	2648	2654	2654	2648	2648
	B	mm	273	273	273	273	273	273	273	273
	C	mm	234	234	228	228	234	234	228	228
	D	mm	2280	2280	2280	2280	2280	2280	2280	2280
	E	mm	150	150	150	150	150	150	150	150
	F	mm	370	370	370	370	370	370	370	370
	G	mm	-	52	80	25	-	52	80	25
	H	mm	-	56	80	90	-	56	80	90
	K	mm	60	45	45	43	60	45	45	43
	L	mm	-	-	60	60	-	-	60	60
	M	mm	-	-	70	50	-	-	70	50
O	mm	-	-	-	90	-	-	-	90	
Support	R	mm	1800	1800	1800	1800	1800	1800	1800	1800
	S	mm	100	100	100	100	100	100	100	100
	T	mm	300	300	300	300	300	300	300	300
Connections	d1	—	J5	J5	J5	J5	J5	J5	J5	J5
	d2	—	FA-35	FA-35	WA-35	WA-22	FA-35	FA-35	WA-35	WA-22
	d3	—	FC-80	FB-54	WA-54	WA-42	FC-80	FB-54	WA-54	WA-42
Volumes - Weight	V_R	dm ³	34,9	34,9	34,9	34,9	38,9	38,9	38,9	38,9
	V_{H_2O}	dm ³	93,3	93,3	93,3	93,3	87,5	87,5	87,5	87,5
	P	kg	270	270	270	270	280	280	280	280
PED category*			III	II	II	II	III	II	II	II

*PED category according to EU Directive 97/23/EC.

The category refers to the use of Group 2 fluids at the PS value of the standard temperature version.

Q_{nom} Nominal cooling capacity

W_{nom} Nominal water flow

W_{max} Maximum water flow

Δp_{nom} Nominal pressure drop (water side)

ΔT_{sc} Subcooling

ΔT_{sh} Superheating

Nominal Conditions	Model	DXS385 - DXD385 DXT385 - DXQ385	DXS450 - DXD450 DXT450 - DXQ450
Refrig.: R407c T_{IN} brine = 12°C T_{OUT} brine = 7°C T_c (dew) = 45.26°C T_v (dew) = 2.75°C ΔT_{sc} = 3K; ΔT_{sh} = 5K Lubricant oil ISO68	Q_{nom} [kW]	385	450
	W_{nom} [m³/h]	66	77,1
	W_{max} [m³/h]	70	100
	Δp_{nom} [bar]	0,38	0,35

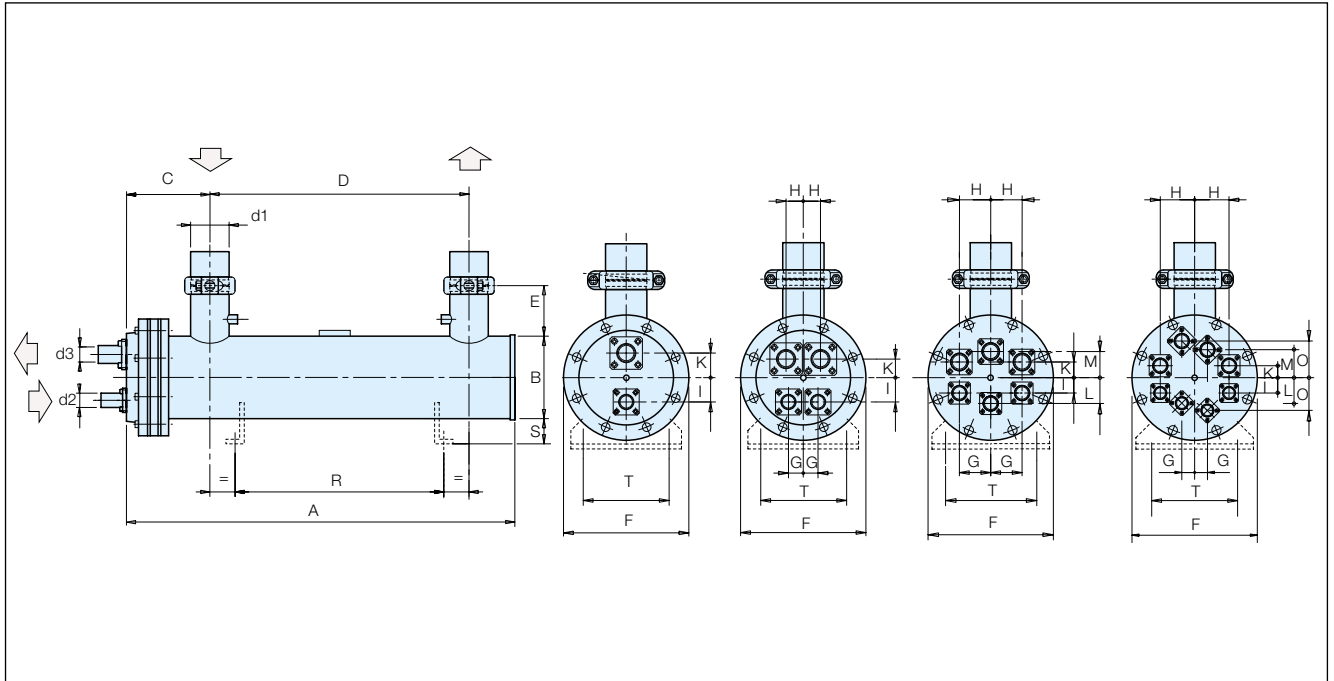

MODEL			DXS 385	DXD 385	DXT 385	DXQ 385	DXS 450	DXD 450	DXT 450	DXQ 450
Dimensions	A	mm	2654	2654	2648	2648	2697	2697	2693	2693
	B	mm	273	273	273	273	324	324	324	324
	C	mm	234	234	228	228	277	277	273	273
	D	mm	2280	2280	2280	2280	2250	2250	2250	2250
	E	mm	150	150	150	150	200	200	200	200
	F	mm	370	370	370	370	420	420	420	420
	G	mm	-	52	80	25	-	60	95	31
	H	mm	-	56	80	90	-	65	95	120
	K	mm	60	45	45	43	70	60	55	40
	I	mm	60	52	45	50	75	60	55	40
	L	mm	-	-	60	60	-	-	80	50
M	mm	-	-	70	50	-	-	80	50	
O	mm	-	-	-	90	-	-	-	100	
Support	R	mm	1800	1800	1800	1800	1800	1800	1800	1800
	S	mm	100	100	100	100	100	100	100	100
	T	mm	300	300	300	300	300	300	300	300
Connections	d1	—	J5	J5	J5	J5	J6	J6	J6	J6
	d2	—	FA-35	FA-35	WA-35	WA-22	FA-35	FA-35	FA-35	FA-35
	d3	—	FC-80	FB-54	WA-54	WA-42	FC-80	FC-80	FB-67	FA-54
Volumes - Weight	V_R	dm³	44,8	44,8	44,8	44,8	52,9	52,9	52,9	52,9
	V_{H_2O}	dm³	80,2	80,2	80,2	80,2	133,4	133,4	133,4	133,4
	P	kg	295	295	295	295	379	379	381	381
PED category*			III	II	II	II	III	II	II	II

*PED category according to EU Directive 97/23/EC.
 The category refers to the use of Group 2 fluids at the PS value of the standard temperature version.

- Q_{nom} Nominal cooling capacity
- W_{nom} Nominal water flow
- W_{max} Maximum water flow
- Δp_{nom} Nominal pressure drop (water side)
- ΔT_{sc} Subcooling
- ΔT_{sh} Superheating

Nominal Conditions	Model	DXS505 - DXD505 DXT505 - DXQ505	DXS570 - DXD570 DXT570 - DXQ570
Refrig.: R407c $T_{IN \text{ brine}} = 12^{\circ}\text{C}$ $T_{OUT \text{ brine}} = 7^{\circ}\text{C}$ $T_c(\text{dew}) = 45,26^{\circ}\text{C}$ $T_{\text{vap}}(\text{dew}) = 2,75^{\circ}\text{C}$ $\Delta T_{sc} = 3\text{K}; \Delta T_{sh} = 5\text{K}$ Lubricant oil ISO68	Q_{nom} [kW]	505	570
	W_{nom} [m ³ /h]	86,5	97,6
	W_{max} [m ³ /h]	100	105
	Δp_{nom} [bar]	0,45	0,50

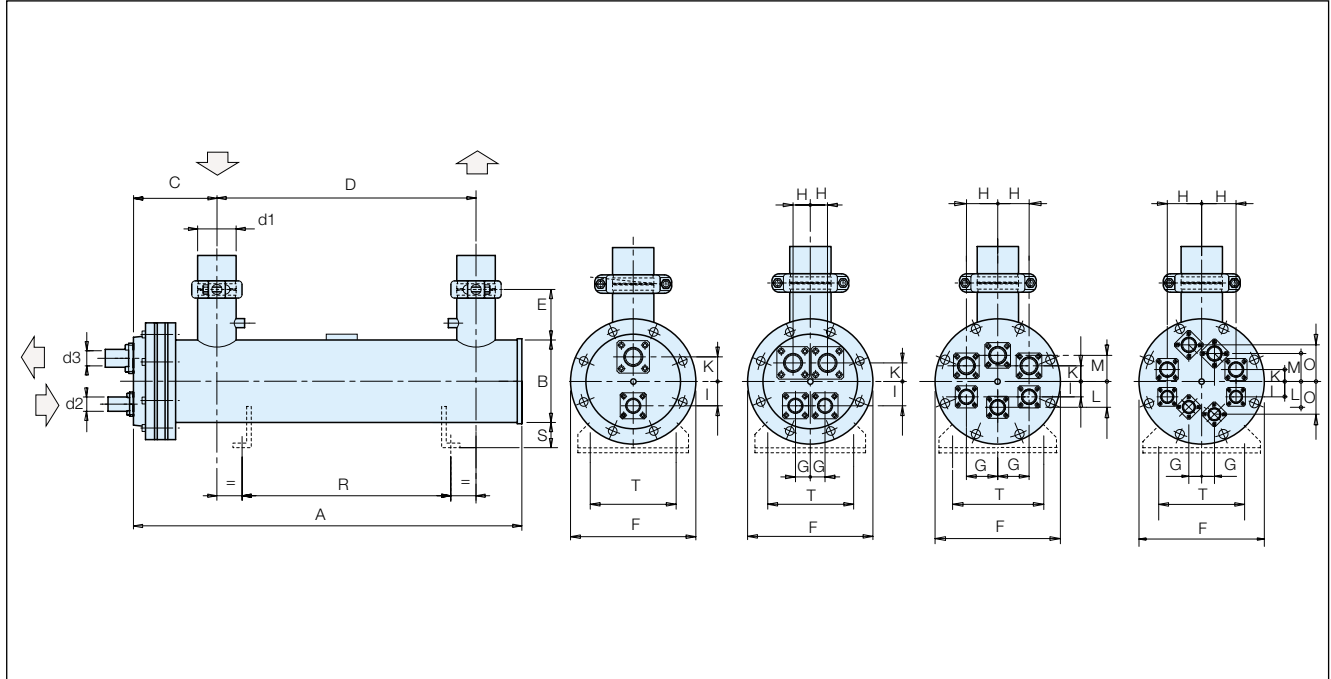

MODEL			DXS 505	DXD 505	DXT 505	DXQ 505	DXS 570	DXD 570	DXT 570	DXQ 570
Dimensions	A	mm	2697	2697	2693	2693	2697	2697	2693	2693
	B	mm	324	324	324	324	324	324	324	324
	C	mm	277	277	273	273	277	277	273	273
	D	mm	2250	2250	2250	2250	2250	2250	2250	2250
	E	mm	200	200	200	200	200	200	200	200
	F	mm	420	420	420	420	420	420	420	420
	G	mm	-	60	95	31	-	60	95	31
	H	mm	-	65	95	120	-	65	95	120
	K	mm	70	60	55	40	70	60	55	40
	I	mm	75	60	55	40	75	60	55	40
Support	R	mm	1800	1800	1800	1800	1800	1800	1800	1800
	S	mm	100	100	100	100	100	100	100	100
	T	mm	300	300	300	300	300	300	300	300
Connections	d1	—	J6	J6	J6	J6	J6	J6	J6	J6
	d2	—	FA-35	FA-35	FA-35	FA-35	FA-35	FA-35	FA-35	FA-35
	d3	—	FC-80	FC-80	FB-67	FA-54	FC-80	FC-80	FB-67	FA-54
Volumes - Weight	V_R	dm ³	59,9	59,9	59,9	59,9	68,8	68,8	68,8	68,8
	V_{H_2O}	dm ³	124,7	124,7	124,7	124,7	113,5	113,5	113,5	113,5
	P	kg	395	395	397	397	417	417	419	419
PED category*			III	II	II	II	III	II	II	II

*PED category according to EU Directive 97/23/EC.
 The category refers to the use of Group 2 fluids at the PS value of the standard temperature version.

Q_{nom} Nominal cooling capacity
 W_{nom} Nominal water flow
 W_{max} Maximum water flow
 Δp_{nom} Nominal pressure drop (water side)
 ΔT_{sc} Subcooling
 ΔT_{sh} Superheating

Nominal Conditions	Model	DXD660 - DXT660 DXQ660	DXD770 - DXT770 DXQ770
Refrig.: R407c $T_{IN, \text{brine}} = 12^{\circ}\text{C}$ $T_{OUT, \text{brine}} = 7^{\circ}\text{C}$ $T_c(\text{dew}) = 45.26^{\circ}\text{C}$ $T_{\text{vap}}(\text{dew}) = 2.75^{\circ}\text{C}$ $\Delta T_{sc} = 3\text{K}; \Delta T_{sh} = 5\text{K}$ Lubricant oil ISO68	Q_{nom} [kW]	660	770
	W_{nom} [m ³ /h]	113	131,9
	W_{max} [m ³ /h]	140	148
	Δp_{nom} [bar]	0,45	0,50

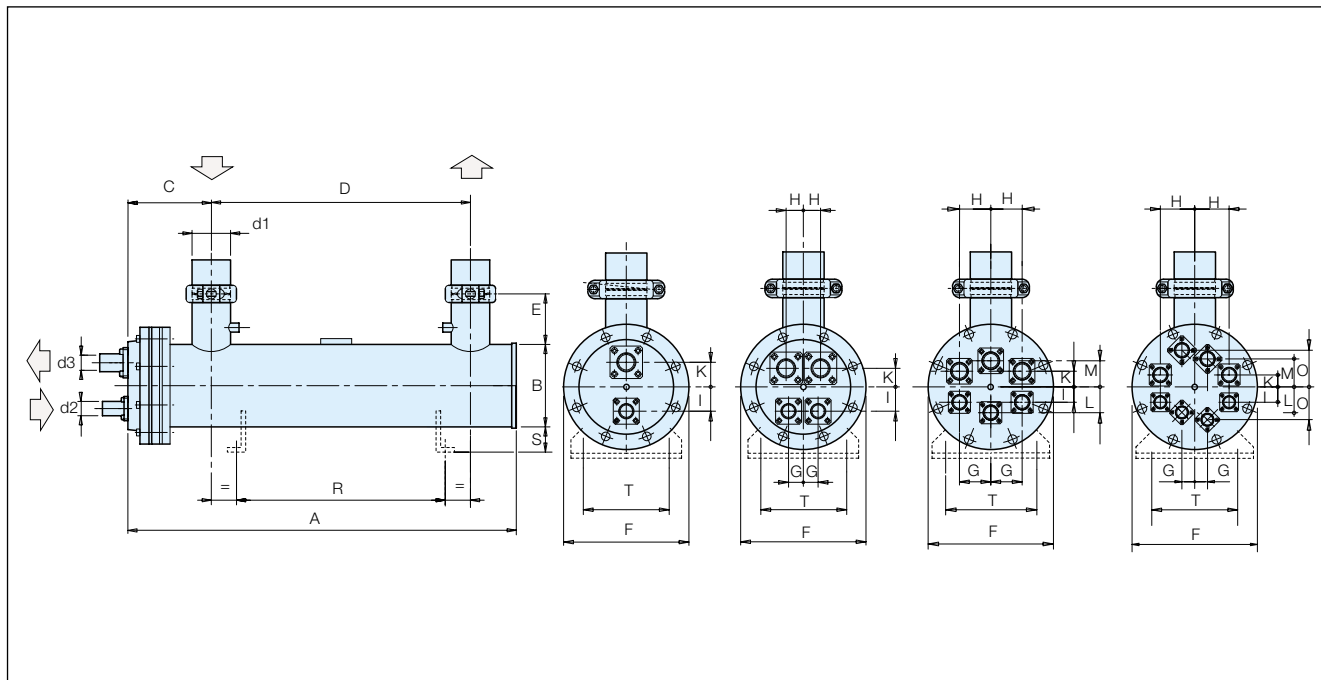

MODEL			DXD 660	DXT 660	DXQ 660	DXD 770	DXT 770	DXQ 770
Dimensions	A	mm	2744	2737	2737	2744	2737	2737
	B	mm	406	406	406	406	406	406
	C	mm	334	327	327	334	327	327
	D	mm	2200	2200	2200	2200	2200	2200
	E	mm	200	200	200	200	200	200
	F	mm	510	510	510	510	510	510
	G	mm	70	120	40	70	120	40
	H	mm	98	120	150	98	120	150
	K	mm	70	70	50	70	70	50
	I	mm	75	70	70	75	70	70
	L	mm	-	110	100	-	110	100
	M	mm	-	110	-	-	110	-
O	mm	-	-	110	-	-	110	
Support	R	mm	1800	1800	1800	1800	1800	1800
	S	mm	120	120	120	120	120	120
	T	mm	400	400	400	400	400	400
Connections	d1	—	J8	J8	J8	J8	J8	J8
	d2	—	FA-35	FA35	FA-35	FA-35	FA-35	FA-35
	d3	—	FC-80	FC-80	FB-67	FC-80	FC-80	FB-67
Volumes - Weight	V_R	dm ³	80,1	80,1	80,1	92,6	92,6	92,6
	V_{H_2O}	dm ³	221,7	221,7	221,7	206,5	206,5	206,5
	P	kg	578	575	575	607	604	604
PED category*			III	II	II	III	II	II

*PED category according to EU Directive 97/23/EC.
 The category refers to the use of Group 2 fluids at the PS value of the standard temperature version.

- Q_{nom} Nominal cooling capacity
- W_{nom} Nominal water flow
- W_{max} Maximum water flow
- Δp_{nom} Nominal pressure drop (water side)
- ΔT_{sc} Subcooling
- ΔT_{sh} Superheating

Nominal Conditions	Model	DXD915 - DXT915 DXQ915	DXD1000 - DXT1000 DXQ1000
Refrig.: R407c $T_{IN \text{ brine}} = 12^{\circ}\text{C}$ $T_{OUT \text{ brine}} = 7^{\circ}\text{C}$ $T_c(\text{dew}) = 45,26^{\circ}\text{C}$ $T_{\text{vap}}(\text{dew}) = 2,75^{\circ}\text{C}$ $\Delta T_{sc} = 3\text{K}; \Delta T_{sh} = 5\text{K}$ Lubricant oil ISO68	Q_{nom} [kW]	915	1000
	W_{nom} [m ³ /h]	156,7	171,2
	W_{max} [m ³ /h]	170	180
	Δp_{nom} [bar]	0,70	0,90

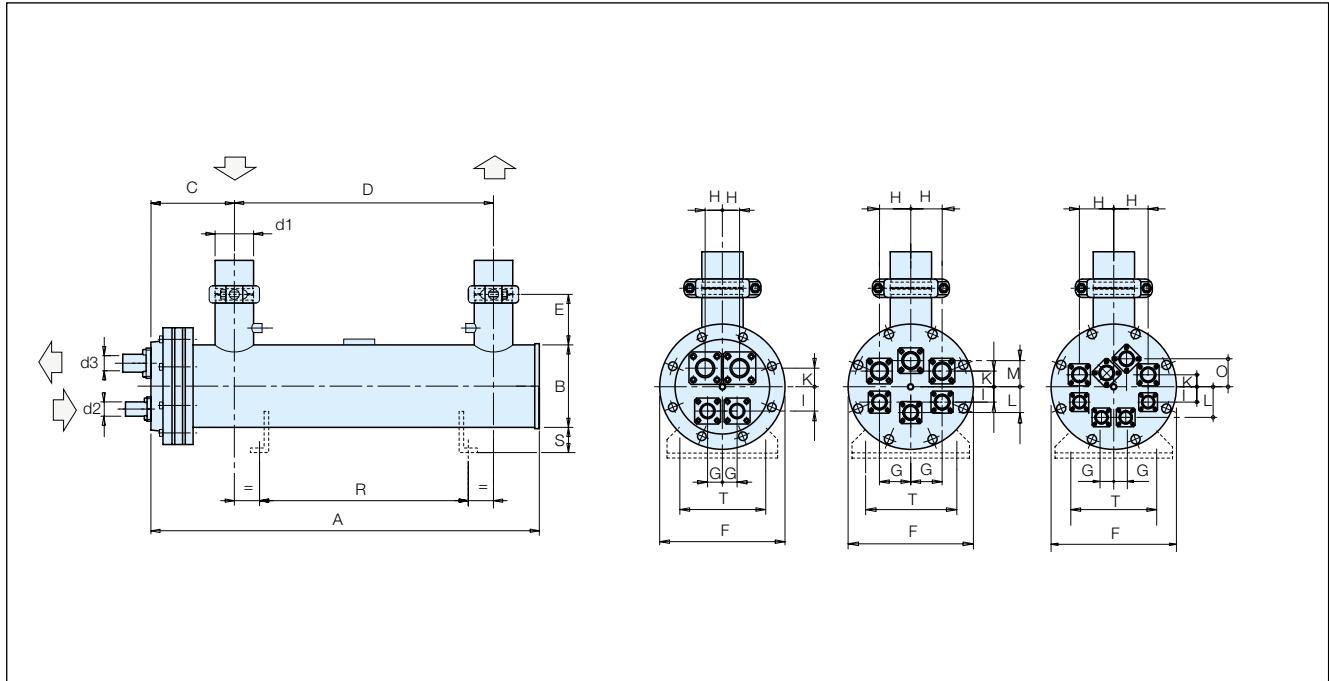

MODEL			DXD 915	DXT 915	DXQ 915	DXD 1000	DXT 1000	DXQ 1000
Dimensions	A	mm	2744	2737	2737	3244	3237	3237
	B	mm	406	406	406	406	406	406
	C	mm	334	327	327	334	327	327
	D	mm	2200	2200	2200	2700	2700	2700
	E	mm	200	200	200	200	200	200
	F	mm	510	510	510	510	510	510
	G	mm	70	120	40	70	120	40
	H	mm	98	120	150	98	120	150
	K	mm	75	70	50	75	70	50
	I	mm	70	70	70	70	70	70
	L	mm	-	110	100	-	110	100
	M	mm	-	110	-	-	110	-
O	mm	-	-	110	-	-	110	
Support	R	mm	1800	1800	1800	2300	2300	2300
	S	mm	120	120	120	120	120	120
	T	mm	400	400	400	400	400	400
Connections	d1	—	J8	J8	J8	J8	J8	J8
	d2	—	FA-35	FA35	FA-35	FA-35	FA-35	FA-35
	d3	—	FC-80	FC-80	FB-67	FC-80	FC-80	FB-67
Volumes - Weight	V_R	dm ³	110,7	110,7	110,7	131,3	131,3	131,3
	V_{H_2O}	dm ³	184,4	184,4	184,4	222,2	222,2	222,2
	P	kg	650	645	645	730	725	725
PED category*			III	III	II	III	III	II

*PED category according to EU Directive 97/23/EC.

The category refers to the use of Group 2 fluids at the PS value of the standard temperature version.

Q_{nom} Nominal cooling capacity
 W_{nom} Nominal water flow
 W_{max} Maximum water flow

Δp_{nom} Nominal pressure drop (water side)
 ΔT_{sc} Subcooling
 ΔT_{sh} Superheating

Nominal Conditions	Model	DXD1100-DXT1100 DXQ1100	DXD1200-DXT1200 DXQ1200	DXD1350-DXT1350 DXQ1350	DXD1500-DXT1500 DXQ1500
Refrig.: R407c $T_{IN, \text{ brine}} = 12^{\circ}\text{C}$ $T_{OUT, \text{ brine}} = 7^{\circ}\text{C}$ $T_{\text{sat}}(\text{dew}) = 45.26^{\circ}\text{C}$ $T_{\text{sat}}(\text{vap}) = 2.75^{\circ}\text{C}$ $\Delta T_{\text{sc}} = 3\text{K}; \Delta T_{\text{sh}} = 5\text{K}$ Lubricant oil ISO68	Q_{nom} [kW]	1100	1200	1350	1500
	W_{nom} [m ³ /h]	188,4	205	232	258
	W_{max} [m ³ /h]	200	220	250	280
	Δp_{nom} [bar]	0,90	0,9	0,8	1,15

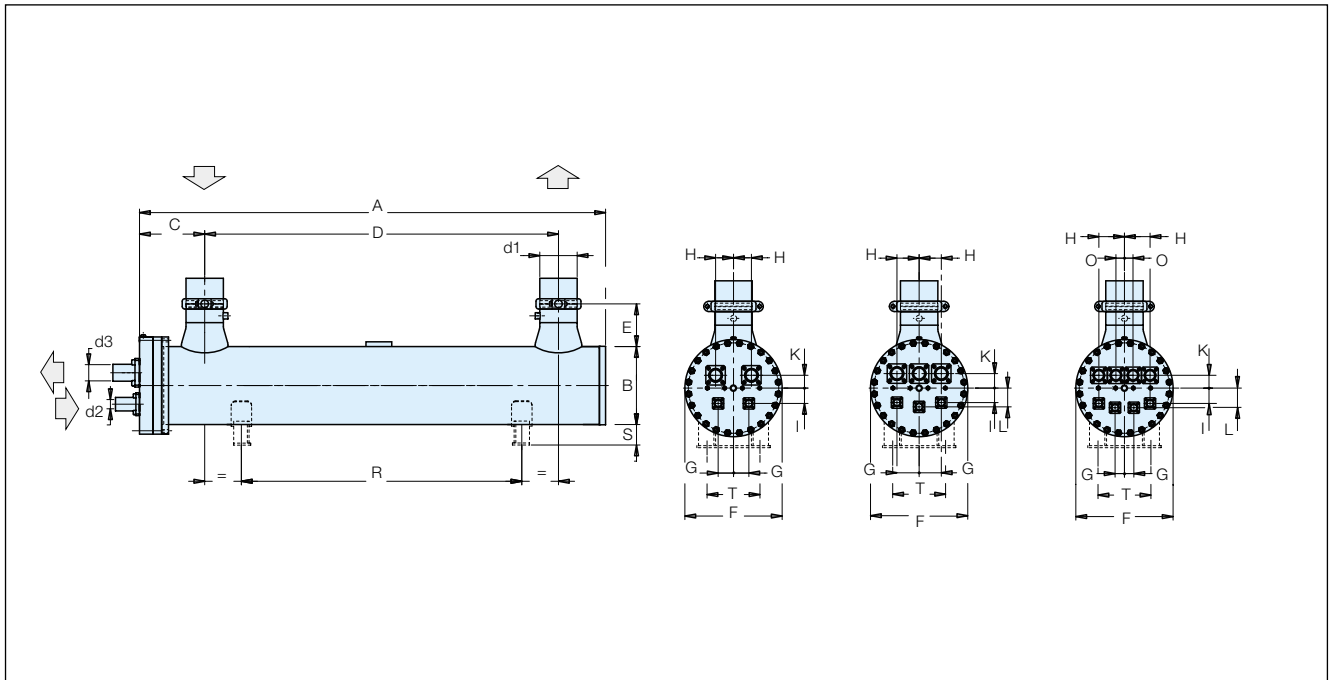

MODEL			DXD 1100	DXT 1100	DXQ 1100	DXD 1200	DXT 1200	DXQ 1200	DXD 1350	DXT 1350	DXQ 1350	DXD 1500	DXT 1500	DXQ 1500
Dimensions	A	mm	2790	2790	2790	3290	3290	3290	3810	3810	3810	3810	3810	3810
	B	mm	457	457	457	457	457	457	508	508	508	508	508	508
	C	mm	382	382	382	382	382	382	392	392	392	392	392	392
	D	mm	2130	2130	2130	2630	2630	2630	3130	3130	3130	3130	3130	3130
	E	mm	250	250	250	250	250	250	250	250	250	250	250	250
	F	mm	570	570	570	570	570	570	640	640	640	640	640	640
	G	mm	90	130	55	90	130	55	100	100	55	100	100	55
	H	mm	105	130	150	105	130	150	100	145	150	100	145	150
	K	mm	75	85	75	75	85	75	100	100	75	100	100	75
	I	mm	90	85	90	90	85	90	100	100	90	100	100	90
	L	mm	-	110	115	-	100	115	-	120	120	-	120	120
M	mm	-	-	-	-	-	-	-	-	-	-	-	-	
O	mm	-	-	-	-	-	-	-	-	50	-	-	50	
Support	R	mm	1700	1700	1700	2200	2200	2200	2700	2700	2700	2700	2700	2700
	S	mm	121	121	121	121	121	121	120	120	120	120	120	120
	T	mm	310	310	310	310	310	310	350	350	350	350	350	350
Connections	d1	—	J8	J8	J8	J8	J8	J8	J8	J8	J8	J8	J8	J8
	d2	—	FA-35	FA-35	FA-35	FA-35	FA-35	FA-35	FA-42	FA-35	FA-35	FA-42	FA-35	FA-35
	d3	—	FC-80	FC-80	FB-67	FC-80	FC-80	FB-67	FC-80	FC-80	FB-67	FC-80	FC-80	FB-67
Volumes - Weight	V _R	dm ³	149	149	149	177	177	177	207	207	207	240	240	240
	V _{H₂O}	dm ³	252	252	252	295	295	295	462	462	462	423	423	423
	P	kg	825	825	825	950	950	950	1100	1100	1100	1200	1200	1200
PED category*			III	III	II	III	III	III	III	III	III	III	III	III

*PED category according to EU Directive 97/23/EC.

The category refers to the use of Group 2 fluids at the PS value of the standard temperature version.

Q_{nom} Nominal cooling capacity

W_{nom} Nominal water flow

W_{max} Maximum water flow

Δp_{nom} Nominal pressure drop (water side)

ΔT_{sc} Subcooling

ΔT_{sh} Superheating

Nominal Conditions	Model	DXS160R - DXD160R DXT160R - DXQ160R	DXS210R - DXD210R DXT210R - DXQ210R
Refrig.: R407c $T_{IN \text{ brine}} = 12^{\circ}\text{C}$ $T_{OUT \text{ brine}} = 7^{\circ}\text{C}$ $T_c(\text{dew}) = 45,26^{\circ}\text{C}$ $T_{\text{vap}}(\text{dew}) = 2,75^{\circ}\text{C}$ $\Delta T_{sc} = 3\text{K}; \Delta T_{sh} = 5\text{K}$ Lubricant oil ISO68	Q_{nom} [kW]	160	210
	W_{nom} [m ³ /h]	27,4	36
	W_{max} [m ³ /h]	31	51
	Δp_{nom} [bar]	0,35	0,25

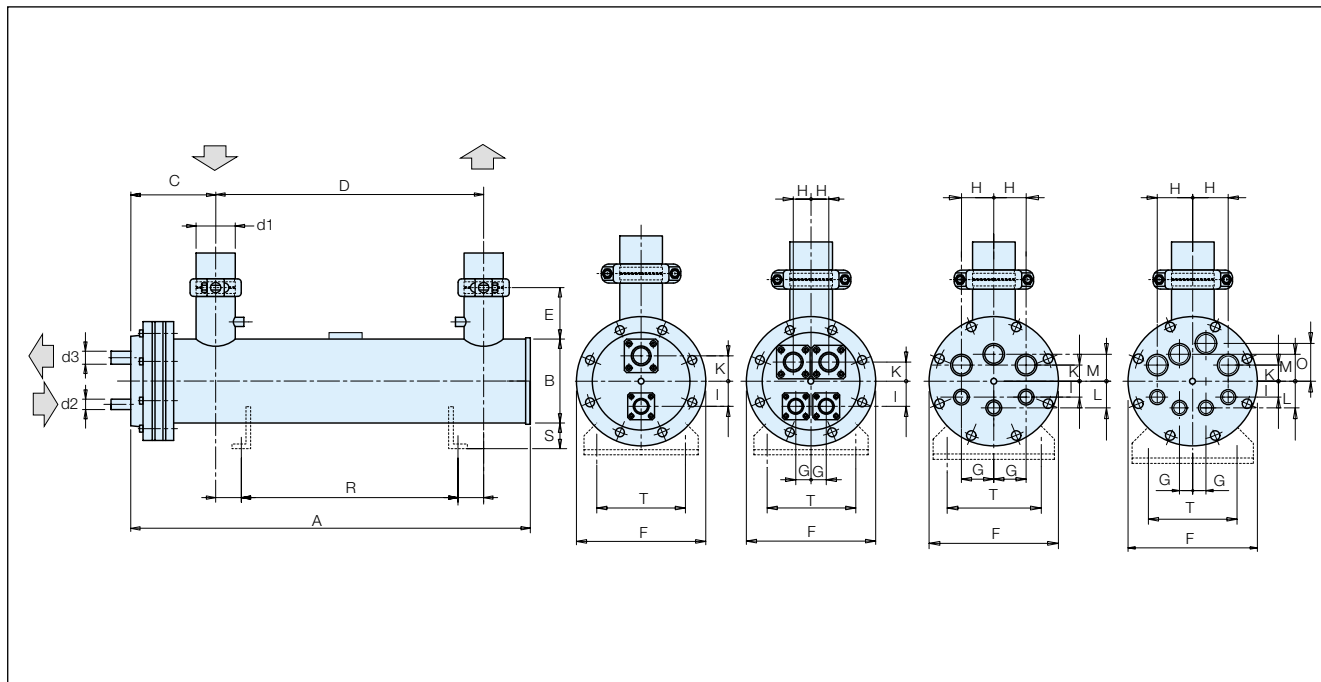

MODEL			DXS 160R	DXD 160R	DXT 160R	DXQ 160R	DXS 210R	DXD 210R	DXT 210R	DXQ 210R
Dimensions	A	mm	1820	1820	1820	1820	1850	1850	1850	1850
	B	mm	219	219	219	219	273	273	273	273
	C	mm	200	200	200	200	222	222	222	222
	D	mm	1500	1500	1500	1500	1500	1500	1500	1500
	E	mm	130	130	130	130	150	150	150	150
	F	mm	310	310	310	310	370	370	370	370
	G	mm	-	42	65	21	-	52	80	25
	H	mm	-	46	65	75	-	56	80	90
	K	mm	46	36	35	36	60	45	45	43
	I	mm	55	44	35	42	60	52	45	50
Support	R	mm	1100	1100	1100	1100	1020	1020	1020	1020
	S	mm	80	80	80	80	100	100	100	100
	T	mm	260	260	260	260	300	300	300	300
Connections	d1	—	T3	T3	T3	T3	J4	J4	J4	J4
	d2	—	FA-35	RC-35	WA-22	WA-22	FA-35	FA-35	WA-35	WA-22
	d3	—	FB-67	FA-54	WA-42	WA-35	FC-80	FB-54	WA-54	WA-42
Volumes - Weight	V_R	dm ³	18,6	18,6	18,6	18,6	24,1	24,1	24,1	24,1
	V_{H_2O}	dm ³	41,8	41,8	41,8	41,8	62,7	62,7	62,7	62,7
	P	kg	150	150	150	150	215	215	215	215
PED category*			II	II	I	I	II	II	II	I

*PED category according to EU Directive 97/23/EC.

The category refers to the use of Group 2 fluids at the PS value of the standard temperature version.

Q_{nom} Nominal cooling capacity
 W_{nom} Nominal water flow
 W_{max} Maximum water flow

Δp_{nom} Nominal pressure drop (water side)
 ΔT_{sc} Subcooling
 ΔT_{sh} Superheating

Nominal Conditions	Model	DXS235R - DXD235R DXT235R - DXQ235R	DXS275R - DXD275R DXT275R - DXQ275R
Refrig.: R407c $T_{IN, \text{brine}} = 12^{\circ}\text{C}$ $T_{OUT, \text{brine}} = 7^{\circ}\text{C}$ $T_{\text{c}}(\text{dew}) = 45.26^{\circ}\text{C}$ $T_{\text{v}}(\text{dew}) = 2.75^{\circ}\text{C}$ $\Delta T_{\text{sc}} = 3\text{K}; \Delta T_{\text{sh}} = 5\text{K}$ Lubricant oil ISO68	Q_{nom} [kW]	235	275
	W_{nom} [m ³ /h]	40,2	47,1
	W_{max} [m ³ /h]	52,6	61,6
	Δp_{nom} [bar]	0,3	0,36

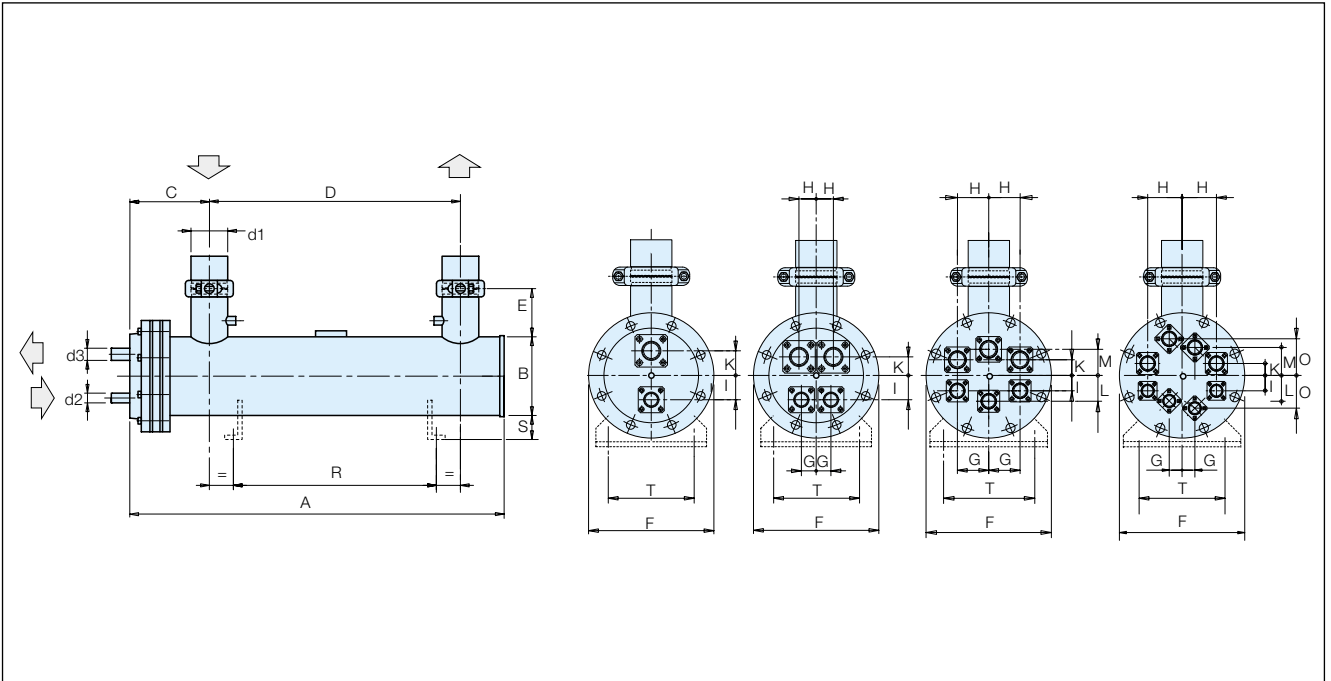

MODEL			DXS 235R	DXD 235R	DXT 235R	DXQ 235R	DXS 275R	DXD 275R	DXT 275R	DXQ 275R
Dimensions	A	mm	1850	1850	1850	1850	1850	1850	1850	1850
	B	mm	273	273	273	273	273	273	273	273
	C	mm	222	222	222	222	222	222	222	222
	D	mm	1500	1500	1500	1500	1500	1500	1500	1500
	E	mm	150	150	150	150	150	150	150	150
	F	mm	370	370	370	370	370	370	370	370
	G	mm	-	52	80	25	-	52	80	25
	H	mm	-	56	80	90	-	56	80	90
	K	mm	60	45	45	43	60	45	45	43
	I	mm	60	52	45	50	60	52	45	50
	L	mm	-	-	60	60	-	-	60	60
M	mm	-	-	70	50	-	-	70	50	
O	mm	-	-	-	90	-	-	-	90	
Support	R	mm	1100	1100	1100	1100	1020	1020	1020	1020
	S	mm	100	100	100	100	100	100	100	100
	T	mm	300	300	300	300	300	300	300	300
Connections	d1	—	J4	J4	J4	J4	J4	J4	J4	J4
	d2	—	FA-35	FA-35	WA-35	WA-22	FA-35	FA-35	WA-35	WA-22
	d3	—	FC-80	FB-54	WA-54	WA-42	FC-80	FB-54	WA-54	WA-42
Volumes - Weight	V_R	dm ³	26,8	26,8	26,8	26,8	30,8	30,8	30,8	30,8
	V_{H_2O}	dm ³	58,1	58,1	58,1	58,1	53,2	53,2	53,2	53,2
	P	kg	230	230	230	230	245	245	245	245
PED category*			II	II	II	I	II	II	II	II

*PED category according to EU Directive 97/23/EC.

The category refers to the use of Group 2 fluids at the PS value of the standard temperature version.

Q_{nom} Nominal cooling capacity

W_{nom} Nominal water flow

W_{max} Maximum water flow

Δp_{nom} Nominal pressure drop (water side)

ΔT_{sc} Subcooling

ΔT_{sh} Superheating

Nominal Conditions	Model	DXS390R-DXD390R DXT390R-DXQ390R	DXS420R-DXD420R DXT420R-DXQ420R	DXS480R-DXD480R DXT480R-DXQ480R
Refrig.: R407c T_{IN} brine = 12°C T_{OUT} brine = 7°C T_c (dew) = 45.26°C T_{vap} (dew) = 2.75°C ΔT_{sc} = 3K; ΔT_{sh} = 5K Lubricant oil ISO68	Q_{nom} [kW]	390	420	480
	W_{nom} [m³/h]	66,8	71,9	82,2
	W_{max} [m³/h]	75	91	100
	Δp_{nom} [bar]	0,4	0,39	0,35

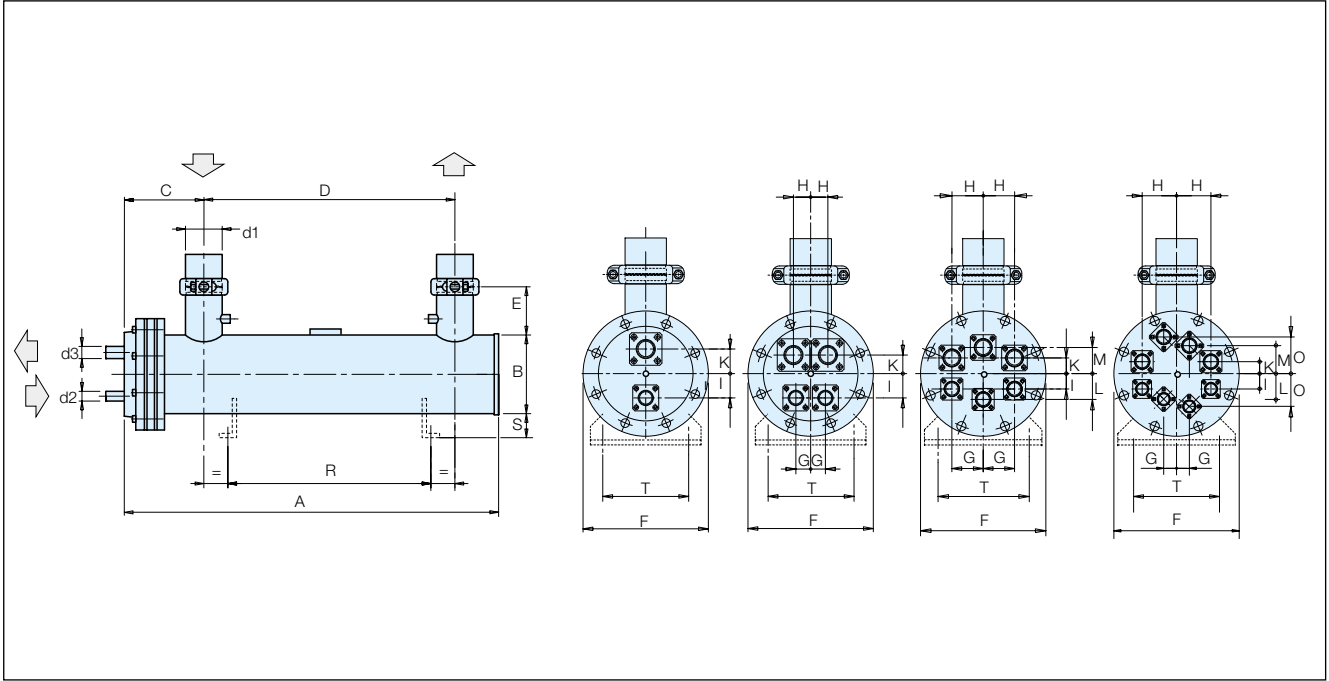

MODEL			DXS 390R	DXD 390R	DXT 390R	DXQ 390R	DXS 420R	DXD 420R	DXT 420R	DXQ 420R	DXS 480R	DXD 480R	DXT 480R	DXQ 480R	
Dimensions	A	mm	2180	2180	2180	2180	2180	2180	2180	2180	2180	2180	2180	2180	
	B	mm	324	324	324	324	324	324	324	324	324	324	324	324	
	C	mm	277	277	277	277	277	277	277	277	277	277	277	277	
	D	mm	1730	1730	1730	1730	1730	1730	1730	1730	1730	1730	1730	1730	
	E	mm	200	200	200	200	200	200	200	200	200	200	200	200	
	F	mm	420	420	420	420	420	420	420	420	420	420	420	420	420
	G	mm	-	60	95	31	-	60	95	31	-	60	95	31	
	H	mm	-	65	95	120	-	65	95	120	-	65	95	120	
	K	mm	70	60	55	40	70	60	55	40	70	60	55	40	
	I	mm	75	60	55	40	75	60	55	40	75	60	55	40	
L	mm	-	-	80	50	-	-	80	50	-	-	80	50		
M	mm	-	-	80	50	-	-	80	50	-	-	80	50		
O	mm	-	-	-	100	-	-	-	100	-	-	-	100		
Support	R	mm	1280	1280	1280	1280	1280	1280	1280	1280	1280	1280	1280	1280	
	S	mm	100	100	100	100	100	100	100	100	100	100	100	100	
	T	mm	300	300	300	300	300	300	300	300	300	300	300	300	
Connections	d1	—	J6	J6	J6	J6	J6	J6	J6	J6	J6	J6	J6	J6	
	d2	—	FA-35	FA-35	FA-35	FA-35	FA-35	FA-35	FA-35	FA-35	FA-35	FA-35	FA-35	FA-35	
	d3	—	FC-80	FC-80	FB-67	FA-54	FC-80	FC-80	FB-67	FA-54	FC-80	FC-80	FB-67	FA-54	
Volumes - Weight	V_R	dm³	42,2	42,2	42,2	42,2	48	48	48	48	51,1	51,1	51,1	51,1	
	V_{H_2O}	dm³	106,1	106,1	106,1	106,1	99,8	99,8	99,8	99,8	89,8	89,8	89,8	89,8	
	P	kg	310	310	310	310	330	330	330	330	350	350	350	350	
PED category*				III	II	II	II	III	II	II	III	II	II	II	

*PED category according to EU Directive 97/23/EC.
The category refers to the use of Group 2 fluids at the PS value of the standard temperature version.

- Q_{nom} Nominal cooling capacity
- W_{nom} Nominal water flow
- W_{max} Maximum water flow
- Δp_{nom} Nominal pressure drop (water side)
- ΔT_{sc} Subcooling
- ΔT_{sh} Superheating

Refrigerant connections

The connection between the evaporator and the refrigerant circuit is made, depending on the evaporator size, with rotalock connections, welding connections or flange connections.

Rotalock connections (R)

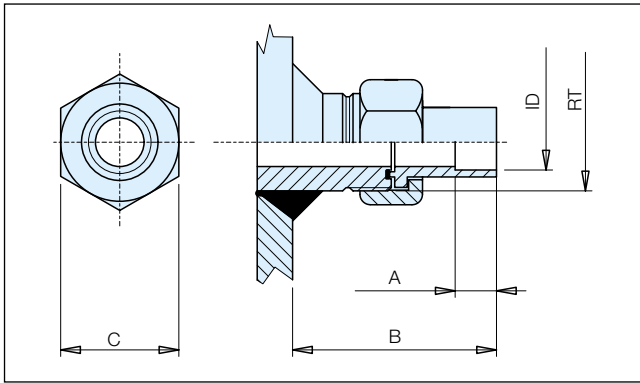

Rotalock								
Type	A	B	C	RT	Name	ODS	ODS	ID
	[mm]	[mm]	[mm]			[mm]	[mm]	[mm]
A	20	80	30	1" - 14UNF	RA16	16	5/8	16,3
B	20	80	36	1 1/4" - 12UNF	RB22	22	7/8	22,5
C	20	80	50	1 3/4" - 12UNF	RC28	28	-	28,3
	20	80	50	1 3/4" - 12UNF	RC35	35	1 3/8	35,3

Welding connections (W)

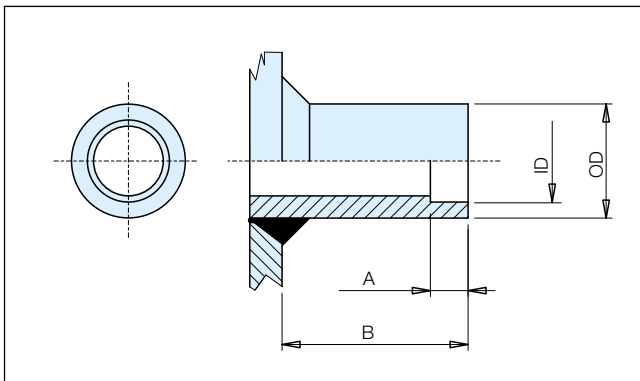

Welding						
Type	A	B	Name	ODS	ID	OD
	[mm]	[mm]		[mm]	[mm]	[mm]
A	20	80	WA22	22	22,5	26,7
	20	80	WA35	35	35,3	42,4
	20	80	WA42	42	42,4	48,3
	20	80	WA54	54	54,5	60,3

Flange connections (F)

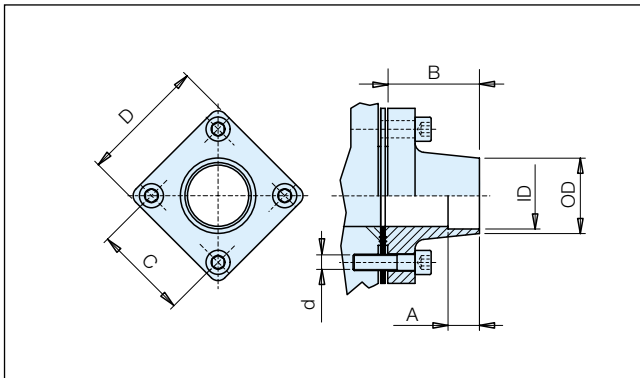

Flange										
Type	A	B	C	D	d	Name	ODS	ODS	ID	OD
	[mm]	[mm]	[mm]	[mm]			[mm]	[mm]	[mm]	[mm]
A	20	60	55	75	M10	FA35	35	1 3/8	35,3	-
	20	60	55	75	M10	FA42	42	-	42,4	-
	20	60	55	75	M10	FA54	54	2 1/8	54,4	-
B	20	70	70	90	M10	FB54	54	2 1/8	54,4	-
	20	70	70	90	M10	FB67	66,7	2 5/8	67,2	76
C	20	70	90	110	M12	FC80	80	-	80,6	88,9

Special connections (flange)

Connection	STANDARD			Connection	SPECIAL					
	Name	ODS			Name		ODS			
					[mm]	[in]	[mm]	[in]	[mm]	[in]
Type A	FA35	35	1 3/8	Type A	FA42	FA54	42	-	54	2 1/8
	FA42	42	-		FA35	FA54	35	1 3/8	54	2 1/8
	FA54	54	2 1/8		FA35	FA42	35	1 3/8	42	-
Type B	FB67	67	2 5/8	Type B	FA54		42		2 1/8	
Type C	FC80	80	-	Type C	FC67		67		2 5/8	
					FC31		-		3 1/8	
					FC89		89		-	

Water connections

Different connections are available, depending on the evaporator size:

- With UNI/ISO 7/1 R thread up to 3";
- With flexible joint starting with 4" (DN 100);
- With UNI 2278 PN 16 flange connections (not standard alternative: to be specified).

The flexible joint gaskets are compatible with liquids normally

used in refrigeration and air conditioning applications and are suitable to be used within -40°C and $+80^{\circ}\text{C}$.

The joints are supplied with the flexible joint and a slot end with groove.

Threaded connections (T)

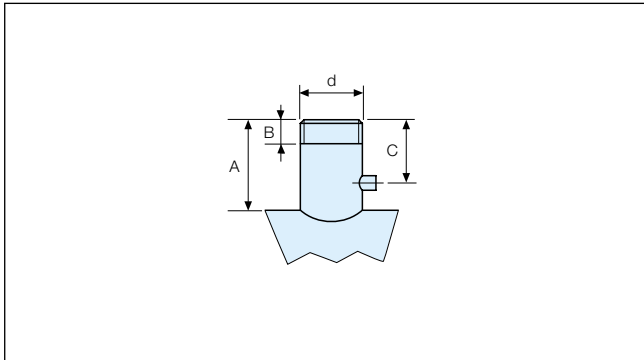

Threaded connections (T)					
Type	A	B	C	Name	d
	[mm]	[mm]	[mm]		[in]
DX18-28	130	25	60	T11	1 1/2
DX35-47	130	25	60	T2	2
DX56-95	130	35	60	T21	2 1/2
DX120-165	130	35	60	T3	3
DX160R	130	35	60	T3	3

Flexible joint (J)

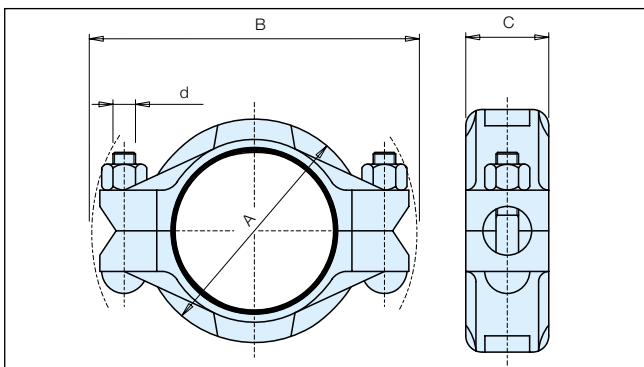

Flexible joint (J)							
Type	A	B	C	d	Name	OD	DN
	[mm]	[mm]	[mm]	[mm]		[mm]	
DX200-240	149,2	212,8	50,8	M12	J4	114,3	100 (4")
DX300-385	177,8	250,8	50,8	M16	J5	141,3	125 (5")
DX450-570	203,2	285,8	50,8	M16	J6	168,3	150 (6")
DX660-1000	263,5	349,3	60,3	M20	J8	219,1	200 (8")
DX1100-1500	263,5	349,3	60,3	M20	J8	219,1	200 (8")
DX210R-275R	149,2	212,8	50,8	M12	J4	114,3	100 (4")
DX390R-480R	203,2	285,8	50,8	M16	J6	168,3	150 (6")

Connection pipe

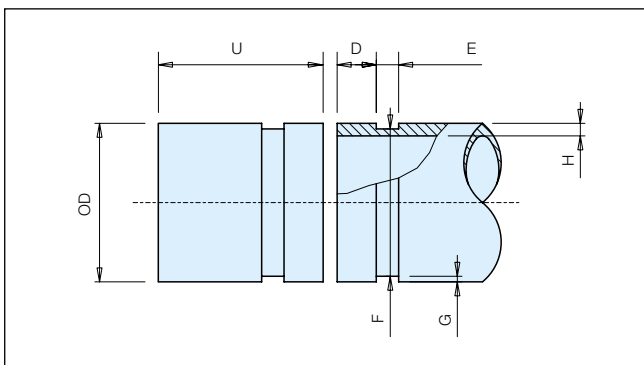

Connection pipe							
Type	DN	D	E	F	G	H	U
		[mm]	[mm]	[mm]	[mm]	[mm]	[mm]
DX200-240	100 (4")	15,9	9,5	110,1	2,1	3,2	100
DX300-385	125 (5")	15,9	9,51	35,5	2,9	4	100
DX450-570	150 (6")	19,5	9,5	163,9	2,2	4	150
DX660-1000	200 (8")	19	11,1	214,4	2,3	6,3	150
DX1100-1500	200 (8")	19	11,1	214,4	2,3	6,3	150
DX210R-275R	100 (4")	15,9	9,5	110,1	2,1	4	100
DX390R-480R	150 (6")	19,5	9,5	163,9	2,2	4	150

Flange connections

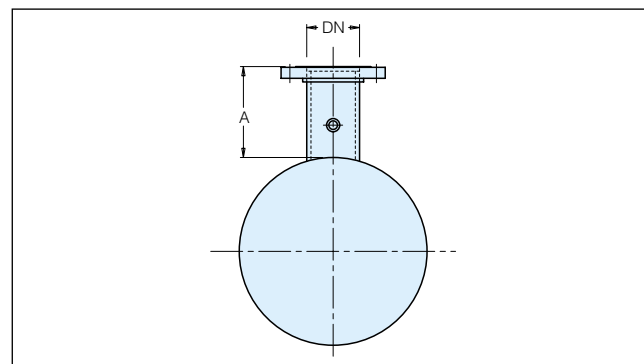

Flange connections		
Type	DN	A
		[mm]
DX18-28	40	130
DX35-47	50	130
DX56-95	65	130
DX120-165 160R	80	130
DX200-240 210R-275R	100	160
DX200-385	125	160
DX450-570 390R-480R	150	210
DX660-1000	200	215
DX1100-1500	200	265

IT Model	240	470	610	1100	1400	2000	2500	3000
DX models to be included	18	56	120	200	300	450	660	1000+500
	28	65	135	240	345	505	770	-
	35	80	165	385	385	570	915	-
	47	95	-	-	-	-	1000	-
	-	-	-	160R	210R	390R	-	-
	-	-	-	-	235R	420R	-	-
	-	-	-	-	275R	480R	-	-

Nominal data	CE	Alfa Laval std.	ASME	SQL	GOST
	STD	STD	STD	STD	STD
DP refrig. (bar)	29	25	15.5	24.5	24.5
TP refrig. (bar)	41.5	27.5	17.05	27	27
DP water (bar)	6*	6*	6	6	6
TP water (bar)	8.6	8.6	6.6	8.6	8.6
DT (°C)	-10	-10	-10	-10	-10
	+90	+90	+90	+90	+90

*Option available with water side DP 10 or 16 bar

MODEL			240	470	610	1100	1400	2000	2500	3000
Dimensions	A	mm	360	415	415	500	500	620	620	620
	B	mm	325	375	375	450	450	575	575	575
	C	mm	950	1200	1700	1800	2300	1800	2300	3000
	D1	mm	500	600	600	750	750	1000	1000	1000
	d2	mm	140	168	194	219	273	324	406	406
	E	mm	1470	1840	2385	2715	3300	2830	3520	4125
	F	mm	1370	1740	2270	2580	3150	2650	3300	3900
	G	mm	1407	1780	2315	2612	2654	2693	3237	3937
	H	mm	165	200	200	245	245	330	330	330
	H1	mm	-	-	-	-	-	205	250	250
	I	mm	65	78	80	82	96	110	130	130
	L	mm	145	175	200	230	285	335	420	420
	M	mm	260	315	315	400	400	520	520	520
	N	mm	275	348	365	472	521	536	580	580
U	mm	-	-	-	100	100	150	150	150	
Connections	d3	GF in	2	2 1/2	3	-	-	-	-	-
		DN in	-	-	-	4	5	6	8	8
	d4	GF in	1/2	1/2	1/2	1/2	1/2	1/2	1/2	1/2
	d5	GF in	1/2	1/2	1/2	1/2	1/2	1/2	1/2	1/2
	d7	GF in	-	-	-	-	-	2	2	2
Volumes - Weight	VH ₂ O	dm ³	250	472	616	1094	1340	2000	2500	2970
	P	kg	57	87	112	158	190	223	264	322

DP: design pressure
 TP: test pressure
 DT: design temperature

GF ISO 228/I G"
 DN Flexible joint

Alfa Laval in brief

Alfa Laval is leading global provider of specialized products and engineering solutions.

Our equipment, systems and services are dedicated to assisting customers in optimizing the performance of their processes. Time and time again.

We help them heat, cool, separate and transport products such as oil, water, chemicals, beverages, foodstuff, starch and pharmaceuticals.

Our worldwide organization works closely with customers in almost 100 countries to help them stay ahead.

