



Alfa Laval AquaMicro

Domestic hot water unit for apartments



Alfa Laval AquaMicro is a complete, installation-ready district heating substation for domestic hot water. It is suitable for apartments and single family houses that are connected to a heating network. Alfa Laval has long experience in district heating technology and has developed AquaMicro with a well-considered function and simple operation. All components are readily accessible for maintenance and future servicing needs.

High comfort

AquaMicro offers fully automatic temperature control for hot water. The hot water is heated by direct exchange with high capacity. This means that the hot water is always as fresh as the incoming cold water.

Simple installation

Small dimensions, low weight, well-designed pipe routing and self-acting control equipment ensure simple installation.

AquaMicro is mounted on an insulated frame and includes an insulated cover. Better insulation means less energy usage and better energy efficiency.

Long-term security

AquaMicro represents the very latest technology and meets very strict long-term performance specifications. The plates and all the pipes in the unit are made from acid-resistant, stainless steel. All components are mutually tuned and are subjected to detailed functional testing according to Alfa Laval's ISO 9001:2008 quality assurance system. AquaMicro is built in compliance with PED 97/23/EC.

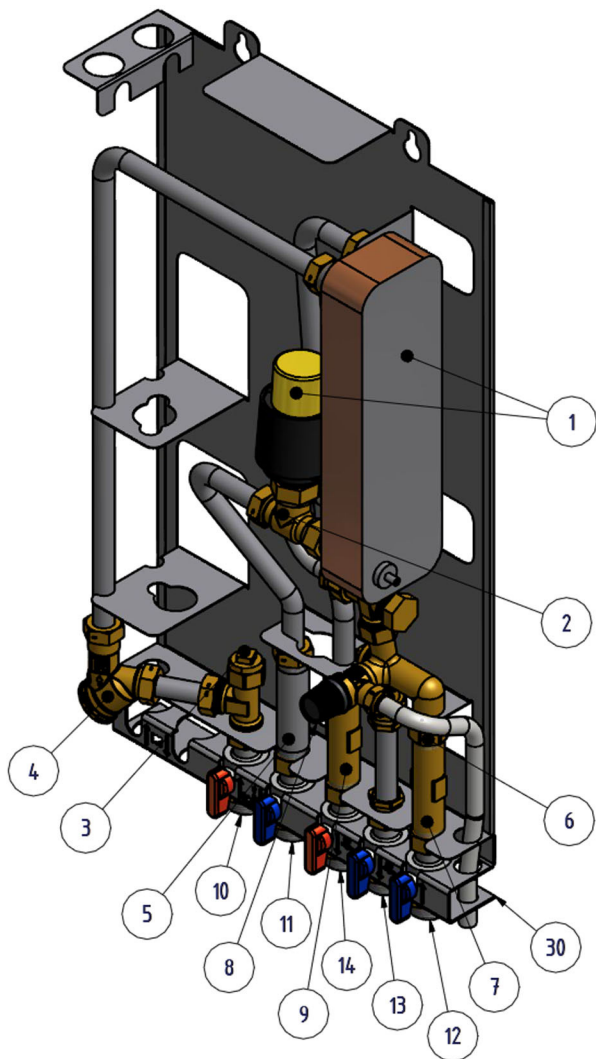

Components

1. Heat exchanger and temperature controller for hot water
2. Control valve for hot water
3. Temperature sensor connection, heating media supply
4. Filter for heating media
5. Adapter for energy meter
6. Check valve for cold water
7. Adapter for Cold water flow meter
8. Safety valve for domestic hot water
9. Adapter for Hot water flow meter
10. Heating network media, supply
11. Heating network media, return
12. Cold water inlet (cw)
13. Cold water outlet (cw)
14. Hot water (hw)
30. First fix jig including shut-off valves (option)

Heating network – a good source of heat

A heating network is an efficient technology that meets the need for hot water in a simple, convenient and secure way.

Operation

AquaMicro is used for the indirect connection of apartments and single family houses to the heating network.

A heat exchanger is used to transfer heat from the heating network medium to the hot water system. Heat is transferred through a package of thin, acid-resistant, stainless steel plates, which keeps the heating network medium separate from the domestic hot water system.

A self-sensing temperature regulator controls the hot water temperature. This measures the temperature of the hot water in the heat exchanger and automatically adjusts the outgoing flow. This patented, in-house Alfa Laval design gives a constant hot water temperature irrespective of volume and pressure flow.

The energy supplier registers use of energy. Measurement is done by recording the flow of heating network medium through the system, and by measuring the temperature difference between the medium's supply and return flow.

Diagrammatic flow chart for AquaMicro

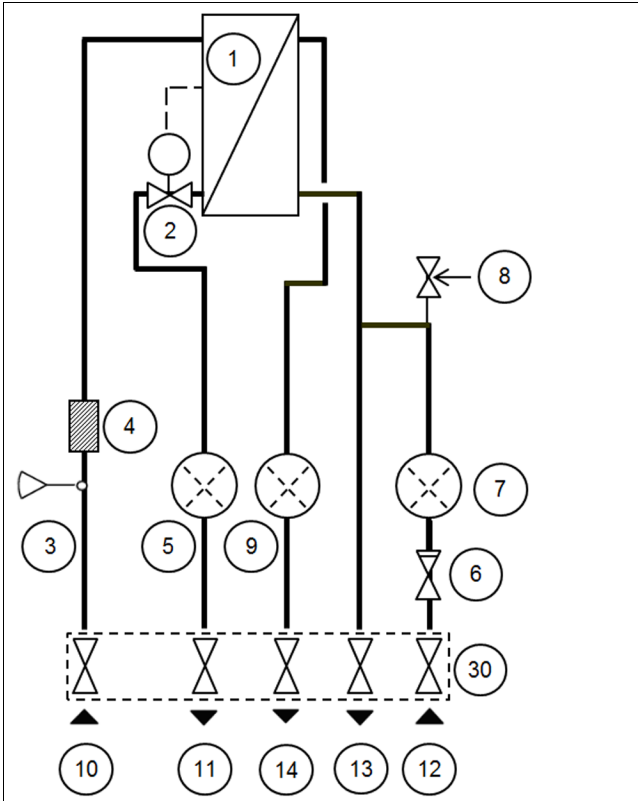

Operating data

	Heating medium	Hot water circuit
Design pressure, MPa	1.6	1.0
Design temperature, °C	120	100
Opening pressure, safety valve, MPa	-	0.9
Volume, l	0.34	0.36

Performance at available differential pressure 50-600 kPa

Designed temperature programme (°C)	Capacity (kW)	Primary flow (l/s)	Actual return temp. (°C)	Secondary flow (l/s)
80-25/10-55	79	0.34	25	0.42
70-25/10-58	36	0.19	25	0.18
65-25/10-50	55	0.33	25	0.33

An easily manageable, economical and durable source of heat

The AquaMicro uses the heating network medium for heating the domestic hot water. The AquaMicro is a wall-mounted unit and is very compact. The unit is discreet and to minimize transmission of operational sounds, we recommend installing it on well insulated walls or on walls of concrete. AquaMicro requires no attendance or maintenance and has a very long operational life. In the event of requiring service or component exchange at some future date, all parts are easily accessible and individually replaceable.

To save time and efficiency the installation, Alfa Laval offers a first-fix- jig including shut-off valves.

Other information

Electrical data: -----
Dimensions (cover): 430 mm width x 160 mm depth, 775 mm height
Dimensions (with out cover): 400 mm width x 120 mm depth, 630 mm height
Weight: 12 kg, cover, 2kg
Transport particulars: Total weight 19 kg, 0.08 m ³

Connections first-fix jig	Internal thread	External thread
Heating network media supply	G 3/4	G 1
Heating network media return	G 3/4	G 1
Cold water inlet	G 3/4	G 1
Cold water outlet	G 3/4	G 1
Hot water	G 3/4	G 1

Option

First fix jig with shut-off valves.

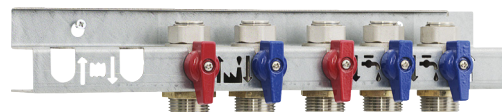

How to contact Alfa Laval

Up-to-date AlfaLaval contact details for all countries are always available on our website on www.alfalaval.com